

TECHNICAL MANUAL

DIRECT SUPPORT AND GENERAL SUPPORT MAINTENANCE MANUAL
(Including Repair Parts and Special Tools List)

FOR

ARTILLERY AMMUNITION FOR GUNS, HOWITZERS,
MORTARS, RECOILLESS RIFLES AND
40MM GRENADE LAUNCHERS

DISTRIBUTION STATEMENT A: Approved for public release; distribution is unlimited.

HEADQUARTERS, DEPARTMENT OF THE ARMY

DECEMBER 1994

WARNINGS

DO NOT USE ANY ELECTRICAL EQUIPMENT AROUND AMMUNITION UNLESS IT HAS A NATIONAL ELECTRICAL CODE RATING OF CLASS I FOR FLAMMABLE VAPOR, CLASS II FOR EXPLOSIVE DUSTS (INCLUDING AMMUNITION), OR IS DUAL RATED IF BOTH VAPOR AND DUSTS ARE PRESENT.

GROUND ALL AMMUNITION CONTAINING EXPLOSIVES WHILE WORKING ON IT.

FUZE CAVITY LINER MUST BE IN PLACE PRIOR TO CLEANING FUZE WELL OR THREADS WITH SMALL STAINLESS STEEL BRUSH.

DO NOT USE ANY ELECTRICAL EQUIPMENT AROUND AMMUNITION WITH EXPLOSIVE (E.G., A SEMIFIXED CARTRIDGE CASE OR A PROJECTILE WITH AN OPEN FUZEWELL) UNLESS IT HAS A NATIONAL ELECTRICAL CODE RATING OF CLASS I FOR FLAMMABLE VAPOR, CLASS II FOR EXPLOSIVE DUSTS (INCLUDING AMMUNITION), OR IS DUAL RATED IF BOTH VAPOR AND DUSTS ARE PRESENT.

ALL AMMUNITION CONTAINING EXPLOSIVES MUST BE GROUNDED WHEN BEING WORKED ON.

ASSURE THAT DECK SANDER OR ANY OTHER POWER TOOL BEING USED FOR DERUSTING IS PROPERLY GROUNDED (I.E., PLUGGED INTO A THREE-WIRE SOCKET OR THE THIRD/WIRE IS SECURELY CONNECTED TO A GOOD GROUND.)

USE ONLY NON-SPARKING WIRE BRUSHES ON AMMUNITION - EVEN ON ARTILLERY PROJECTILES WITH FUZEWELLS SEALED WITH A NOSE PLUG. DO NOT USE WIRE BRUSHES ANYWHERE NEAR PRIMER ON REAR OF CARTRIDGE CASE OR ON FUSES.

ACETONE IS EXTREMELY FLAMMABLE; KEEP AWAY FROM HEAT, SPARKS, AND OPEN FLAMES; KEEP CONTAINER CLOSED; USE ADEQUATE VENTILATION; AND AVOID PROLONGED OR REPEATED CONTACT WITH THE SKIN. THE VAPOR IS HEAVIER THAN AIR AND MAY TRAVEL CONSIDERABLE DISTANCE TO A SOURCE OF IGNITION AND FLASHBACK. ACETONE CAN REACT VIGOROUSLY WITH OXIDIZING MATERIALS.

NEVER ATTEMPT TO CLEAN THE ELECTRIC PRIMER OF THE CARTRIDGE BY ANY METAL OBJECT OR TOOL.

FUZE CAVITY LINER MUST BE IN PLACE PRIOR TO CLEANING FUZE WELL OR THREADS WITH SMALL STAINLESS STEEL BRUSH, OR ACETONE DAMPENED RAGS.

STORE RAGS IN NONCOMBUSTIBLE SELF-CLOSING CONTAINERS. PLACE WASTES OR USED RAGS IN WATER FILLED CONTAINERS. AREAS WILL BE WELL VENTILATED WHERE SOLVENTS AND PAINTS ARE USED.

PALLETS MARKED WITH LETTER "P" HAVE BEEN TREATED WITH PENTACHLOROPHENOL (PENTA) AND MUST NOT BE BURNED.

IF AT ANY TIME DURING REPLACEMENT OF BURSTERS, SMOKE OR HEAT IS OBSERVED ESCAPING FROM THE FUZE WELL, IMMEDIATELY IMMERSE PROJECTILE IN A DRUM OF WATER. DESTROY PROJECTILE IN ACCORDANCE WITH LOCAL REGULATIONS.

TM 9-1300-251-34&P

DO NOT DIRECTLY APPLY ANY FORM OF TAPE TO SURFACE OF COMBUSTIBLE CARTRIDGE CASE. IF TAPE IS APPLIED TO COMBUSTIBLE CASE, REMOVAL OF TAPE MAY CAUSE PEELING OFF OF POLYURETHANE FINISH.

DO NOT USE ANY FORM OF CLEANING SOLVENT OR WATER TO CLEAN THE COMBUSTIBLE CARTRIDGE CASE.

DO NOT BUFF AREA WITH YELLOWISH-WHITE COMBUSTIBLE MATERIAL SHOWING. COMBUSTIBLE MATERIAL IS FRICTION SENSITIVE AND CAN AUTO-IGNITE CAUSING A SERIOUS FIRE HAZARD.

WEAR RESPIRATOR DURING SPRAY PAINT OPERATIONS.

DO NOT ALLOW ACETONE TO COME IN CONTACT WITH THE COMBUSTIBLE CARTRIDGE CASE.

CHANGE)
)
NO. 11)

HEADQUARTERS
DEPARTMENT OF THE ARMY
WASHINGTON, DC, 20 JUNE 2008

**Direct Support and General Support Maintenance Manual
(Including Repair Parts and Special Tools List)
for
Artillery Ammunition for Guns, Howitzers, Mortars,
Recoilless Rifles, and 40mm Grenade Launchers**

DISTRIBUTION STATEMENT A - Approved for public release; distribution is unlimited.

TM 9-1300-251-34&P, 15 December 1994, is changed as follows:

1. File this change sheet after the Warning Summary for reference purposes.
2. Remove old pages and insert new pages as indicated below.
3. New or changed material is indicated by a vertical bar in the outer margin of the page.
4. Added or revised illustrations are indicated by a vertical bar adjacent to the illustration identification number.

Remove Pages

a and b
A and B
i thru vi
4-1 and 4-2
None
B-5 thru B-12
E-1 thru E-4
E-9 and E-10
None
None
E-74.1 and E-74.2
E-77 and E-78

Insert Pages

a and b
A and B
i thru vi
4-1 and 4-2
4-39 and 4-40
B-5 thru B-12
E-1 thru E-4
E-9 and E-10
E-20.3 and E-20.4
E-24.3 and E-24.4
E-74.1 and E-74.2
E-77 and E-78

By Order of the Secretary of the Army:

GEORGE W. CASEY, JR.
General, United States Army
Chief of Staff

Official:

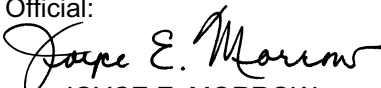
JOYCE E. MORROW
Administrative Assistant to the
Secretary of the Army
0814808

DISTRIBUTION: To be distributed in accordance with the initial distribution number (IDN) 400709 requirements for TM 9-1300-251-34&P.

CHANGE)
)
NO. 10)

HEADQUARTERS
DEPARTMENT OF THE ARMY
WASHINGTON, DC, 01 September 2006

**Direct Support and General Support Maintenance Manual
(Including Repair Parts and Special Tools List)
for
Artillery Ammunition for Guns, Howitzers, Mortars, Recoilless Rifles,
and 40MM Grenade Launchers**

DISTRIBUTION STATEMENT A - Approved for public release; distribution is unlimited.

TM 9-1300-251-34&P, 15 December 1994, is changed as follows:

1. File this change sheet after the Warning Summary for reference purposes.
2. Remove old pages and insert new pages as indicated below.
3. New or changed material is indicated by a vertical bar in the outer margin of the page.
4. Added or revised illustrations are indicated by a vertical bar adjacent to the illustration identification number.

Remove Pages

A and B
iii thru vi
B-5 and B-6
B-11 and B-12
E-1 thru E-4
E-58.1 and E-58.2
E-70.1 and E-70.2
E-74.1 and E-74.2
E-99 and E-100
None

Insert Pages

A and B
iii thru vi
B-5 and B-6
B-11 and B-12
E-1 thru E-4
E-58.1 and E-58.2
E-70.1 and E-70.2
E-74.1 and E-74.2
E-99 and E-100
E-100.1 and E-100.2

By Order of the Secretary of the Army:

Official:

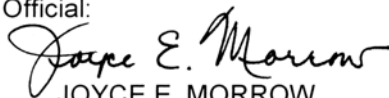

JOYCE E. MORROW

Administrative Assistant to the
Secretary of the Army

0613702

PETER J. SCHOOMAKER
General, United States Army
Chief of Staff

DISTRIBUTION: To be distributed in accordance with the initial distribution number (IDN) 400709 requirements for TM 9-1300-251-34&P.

CHANGE)
)
NO. 9)

HEADQUARTERS
DEPARTMENT OF THE ARMY
WASHINGTON, DC, 25 January 2005

**Direct Support and General Support Maintenance Manual
(Including Repair Parts and Special Tools List)
for
Artillery Ammunition for Guns, Howitzers, Mortars, Recoilless Rifles,
and 40MM Grenade Launcher**

DISTRIBUTION STATEMENT A: Approved for public release; distribution is unlimited.

TM 9-1300-251-34&P, 15 December 1994, is changed as follows:

1. File this change sheet in front of the publication for reference purposes.
2. Remove old pages and insert new pages as indicated below.
3. New or changed material is indicated by a vertical bar in the outer margin of the page.

Remove Pages

A and B
iii thru vi
B-3 thru B-6
E-1 and E-2
E-33 and E-34
None
None

Insert Pages

A and B
iii thru vi
B-3 thru B-6
E-1 and E-2
E-33 and E-34
E-58.1 thru E-58.4
E-74.1 and E-74.2

By Order of the Secretary of the Army:

Official:

SANDRA R. RILEY
Administrative Assistant to the
Secretary of the Army
0435701

PETER J. SCHOOMAKER
General, United States Army
Chief of Staff

DISTRIBUTION: To be distributed in accordance with the initial distribution number (IDN) 400709 requirements for TM 9-1300-251-34&P.

CHANGE)
)
NO. 8)

HEADQUARTERS
DEPARTMENT OF THE ARMY
WASHINGTON, DC, 13 May 2004

**Direct Support and General Support Maintenance Manual
(Including Repair Parts and Special Tools List)
for
Artillery Ammunition for Guns, Howitzers, Mortars, Recoilless Rifles,
and 40MM Grenade Launcher**

DISTRIBUTION STATEMENT A: Approved for public release; distribution is unlimited.

TM 9-1300-251-34&P, 15 December 1994, is changed as follows:

1. File this change sheet in front of the publication for reference purposes.
2. Remove old pages and insert new pages as indicated below.
3. New or changed material is indicated by a vertical bar in the outer margin of the page.

Remove Pages

A and B
i and ii
B-1 and B-2

Insert Pages

A and B
i and ii
B-1 and B-2

By Order of the Secretary of the Army:

PETER J. SCHOOMAKER
General, United States Army
Chief of Staff

Official:

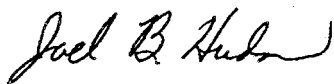

JOEL B. HUDSON
Administrative Assistant to the
Secretary of the Army
0411308

DISTRIBUTION: To be distributed in accordance with the initial distribution number (IDN) 400709 requirements for TM 9-1300-251-34&P.

CHANGE)
)
NO. 7)

HEADQUARTERS
DEPARTMENT OF THE ARMY
WASHINGTON, DC, 29 August 2003

**Direct Support and General Support Maintenance Manual
(Including Repair Parts and Special Tools List)
for
Artillery Ammunition for Guns, Howitzers, Mortars, Recoilless Rifles,
and 40MM Grenade Launcher**

DISTRIBUTION STATEMENT A: Approved for public release; distribution is unlimited.

TM 9-1300-251-34&P, 15 December 1994, is changed as follows:

1. File this change sheet in front of the publication for reference purposes.
2. Remove old pages and insert new pages as indicated below.
3. New or changed material is indicated by a vertical bar in the outer margin of the page.
4. Added or revised illustrations are indicated by a vertical bar adjacent to the illustration identification number.

Remove Pages

A and B
i and ii
v and vi
3-5 and 3-6
4-33 and 4-34
B-7 thru B-10
E-1 and E-2
E-23 and E-24
None
E-48.1 and E-48.2
E-73 and E-74
E-77 thru E-80

Insert Pages

A and B
i and ii
v and vi
3-5 and 3-6
4-33 thru 4-38
B-7 thru B-10
E-1 and E-2
E-23 and E-24
E-24.1 and E-24.2
E-48.1 and E-48.2
E-73 and E-74
E-77 thru E-80

By Order of the Secretary of the Army:

PETER J. SCHOOMAKER
General, United States Army
Chief of Staff

Official:

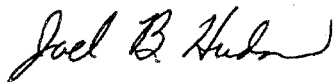

JOEL B. HUDSON
Administrative Assistant to the
Secretary of the Army
0324001

DISTRIBUTION: To be distributed in accordance with the initial distribution number (IDN) 400709 requirements for TM 9-1300-251-34&P.

CHANGE)
)
NO. 6)

HEADQUARTERS
DEPARTMENT OF THE ARMY
WASHINGTON, DC, 14 February 2003

**Direct Support and General Support Maintenance Manual
(Including Repair Parts and Special Tools List)
for
Artillery Ammunition for Guns, Howitzers, Mortars, Recoilless Rifles,
and 40MM Grenade Launchers**

DISTRIBUTION STATEMENT A: Approved for public release; distribution is unlimited.

TM 9-1300-251-34&P, 15 December 1994, is changed as follows:

1. File this change sheet in front of the publication for reference purposes.
2. Remove old pages and insert new pages as indicated below.
3. New or changed material is indicated by a vertical bar in the outer margin of the page.
4. Added or revised illustrations are indicated by a vertical bar adjacent to the illustration identification number.

Remove Pages

A and B
B-5 and B-6
E-1 thru E-4
E-69 and E-70
None

Insert Pages

A and B
B-5 and B-6
E-1 thru E-4
E-69 and E-70
E-70.1 and E-70.2

By Order of the Secretary of the Army:

ERIC K. SHINSEKI
General, United States Army
Chief of Staff

Official:

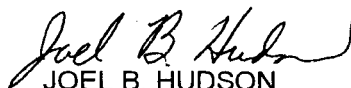

JOEL B. HUDSON

*Administrative Assistant to the
Secretary of the Army*

0303501

DISTRIBUTION: To be distributed in accordance with the initial distribution number (IDN) 400709 requirements for TM 9-1300-251-34&P.

CHANGE)
)
NO. 5)

HEADQUARTERS
DEPARTMENT OF THE ARMY
WASHINGTON, DC, 24 January 2002

**Direct Support and General Support Maintenance Manual
(Including Repair Parts and Special Tools List)
for
Artillery Ammunition for Guns, Howitzers, Mortars, Recoilless Rifles,
and 40MM Grenade Launchers**

DISTRIBUTION STATEMENT A: Approved for public release; distribution is unlimited.

TM 9-1300-251-34&P, 15 December 1994, is changed as follows:

1. File this change sheet in front of the publication for reference purposes.
2. Remove old pages and insert new pages as indicated below.
3. New or changed material is indicated by a vertical bar in the outer margin of the page.
4. Added or revised illustrations are indicated by a vertical bar adjacent to the illustration identification number.

Remove Pages

A and B
B-1 and B-2
B-7 and B-8

Insert Pages

A and B
B-1 and B-2
B-7 and B-8

By Order of the Secretary of the Army:

Official:

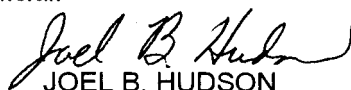

JOEL B. HUDSON

*Administrative Assistant to the
Secretary of the Army*

0201601

ERIC K. SHINSEKI
*General, United States Army
Chief of Staff*

DISTRIBUTION: To be distributed in accordance with the initial distribution number (IDN) 400709 requirements for TM 9-1300-251-34&P.

CHANGE)
)
NO. 4)

HEADQUARTERS
DEPARTMENT OF THE ARMY
WASHINGTON, DC, 30 August 2001

**Direct Support and General Support Maintenance Manual
(Including Repair Parts and Special Tools List)
for
Artillery Ammunition for Guns, Howitzers, Mortars, Recoilless Rifles,
and 40MM Grenade Launchers**

DISTRIBUTION STATEMENT A: Approved for public release; distribution is unlimited.

TM 9-1300-251-34&P, 15 December 1994, is changed as follows:

1. File this change sheet in front of the publication for reference purposes.
2. Remove old pages and insert new pages as indicated below.
3. New or changed material is indicated by a vertical bar in the outer margin of the page.
4. Added or revised illustrations are indicated by a vertical bar adjacent to the illustration identification number.

Remove Pages

A and B
iii thru vi
3-3 and 3-4
None
3-7 thru 3-10
None
3-11 and 3-12
4-5 and 4-6
4-9 and 4-10
4-13 thru 4-16
4-23 and 4-24
None
B-7 and B-8
B-11 and B-12
E-1 thru E-4
E-47 and E-48
None
E-85 and E-86
None

Insert Pages

A and B
iii thru vi
3-3 and 3-4
3-4.1 and 3-4.2
3-7 thru 3-10
3-10.1 and 3-10.2
3-11 and 3-12
4-5 and 4-6
4-9 and 4-10
4-13 thru 4-16
4-23 and 4-24
4-24.1 and 4-24.2
B-7 and B-8
B-11 and B-12
E-1 thru E-4
E-47 and E-48
E-48.1 and E-48.2
E-85 and E-86
E-86.1 and E-86.2

By Order of the Secretary of the Army:

Official:

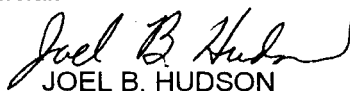

JOEL B. HUDSON

Administrative Assistant to the
Secretary of the Army

0122703

ERIC K. SHINSEKI
General, United States Army
Chief of Staff

DISTRIBUTION: To be distributed in accordance with the initial distribution number (IDN) 400709 requirements for TM 9-1300-251-34&P.

**TM 9-1300-251-34&P
C3**

CHANGE

NO. 3

HEADQUARTERS
DEPARTMENT OF THE ARMY
Washington, DC, 4 January 2000

**DIRECT SUPPORT AND GENERAL SUPPORT
MAINTENANCE MANUAL
(Including Repair Parts and Special Tools List)
FOR
ARTILLERY AMMUNITION FOR GUNS, HOWITZERS, MORTARS, RECOILLESS RIFLES,
AND 40MM GRENADE LAUNCHERS**

DISTRIBUTION STATEMENT A: Approved for public release; distribution is unlimited.

TM 9-1300-251-34&P, dated 15 December 1994, is changed as follows:

1. Remove old pages and insert new pages as indicated below. New or changed material is indicated by a vertical bar in the margin of the page. Added or revised illustrations are indicated by a vertical bar adjacent to the identification number.

Remove pages

A and B
B-1 and B-2

Insert pages

A and B
B-1 and B-2

2. File this change sheet in front of the publication for reference purposes.

TM 9-1300-251-34&P
C3

By Order of the Secretary of the Army:

Official:

JOEL B. HUDSON
*Administrative Assistant to the
Secretary of the Army*
0001205

ERIC K. SHINSEKI
*General, United States Army
Chief of Staff*

Distribution:

To be distributed in accordance with initial distribution number (IDN) 400709, with requirements for TM 9-1300-251-34&P.

**TM 9-1300-251-34&P
C2**

CHANGE

NO. 2

HEADQUARTERS
DEPARTMENT OF THE ARMY
Washington, DC, *1 March 1999*

**DIRECT SUPPORT AND GENERAL SUPPORT
(INCLUDING REPAIR PARTS AND SPECIAL TOOLS LIST)
FOR
ARTILLERY AMMUNITION FOR GUNS,
HOWITZERS, MORTARS, RECOILLESS RIFLES, AND
40MM GRENADE LAUNCHERS**

DISTRIBUTION STATEMENT A: Approved for public release; distribution is unlimited.

DESTRUCTION NOTICE: Destroy by any method that will prevent disclosure of or reconstruction of the document.

TM 9-1300-251-34&P, dated 15 December 1994 is changed as follows:

1. Remove old pages and insert new pages as indicated below. New or changed material is indicated by a vertical bar in the margin of the page. Added or revised illustrations are indicated by a vertical bar adjacent to the identification number.

Remove Page

None
B-9 and B-10
E-79 and E80

Insert Page

A and B
B-9 and B-10
E-79 thru E-82

2. File this change sheet in front of the publication for reference purposes.

TM 9-1300-251-34&P

By Order of the Secretary of the Army

Official:



Handwritten signature of Joel B. Hudson in black ink.

JOEL B. HUDSON

Administrative Assistant to the
Secretary of the Army

05701

DENNIS J. REIMER
General, United States Army
Chief of Staff

Distribution;

To be distributed in accordance with IDN 40-0709, requirements for TM 9-1300-251-34&P.

Change)
)
No. 1)

HEADQUARTERS
DEPARTMENT OF THE ARMY
Washington, D.C., 31 July 1996

**DIRECT SUPPORT AND GENERAL SUPPORT
MAINTENANCE MANUAL
(Including Repair Parts and Special Tools List)
FOR
ARTILLERY AMMUNITION FOR GUNS, HOWITZERS, MORTARS, RECOILLESS RIFLES,
AND 40MM GRENADE LAUNCHERS**

DISTRIBUTION STATEMENT A: Approved for public release; distribution is unlimited.

TM 9-1300-251-34&P, dated 15 Dec 1994 is changed as follows:

1. Remove old pages and insert new pages as indicated below. New or changed material is indicated by a vertical bar in the margin of the page. New or changed illustrations are indicated by a black bar adjacent to the identification number.

Remove Pages

A and B
iii thru vi
B-1 and B-2
None
E-1 and E-2
None
None

Insert Pages

None
iii thru vi
B-1 and B-2
B-2.1 and B-2.2
E-1 and E-2
E-2.1 and E-2.2
E-20.1 and E-20.2

2. File this change sheet in front of the publication for reference purposes.

By Order of the Secretary of the Army:

DENNIS J. REIMER
General, United States Army
Chief of Staff

Official:

JOEL B. HUDSON
*Administrative Assistant to -the
Secretary of the Army*
02467

Distribution:

To be distributed in accordance with DA Form 12-40-E, Block 0709, requirements for TM 9-1300-251-34&P.

LIST OF EFFECTIVE PAGES

INSERT LATEST CHANGED PAGES. DESTROY SUPERSEDED PAGES.

NOTE The portion of the text affected by the changes is indicated by a vertical line in the outer margins of the page. Changes to illustrations are indicated by a vertical line adjacent to the identification number.

Dates of issue for original and changed pages are:

Original 0 15 December 1994	Change 6 14 February 2003
Change 1 31 July 1996	Change 7 29 August 2003
Change 2 1 March 1999	Change 8 13 May 2004
Change 3 4 January 2000	Change 9 25 January 2005
Change 4 30 August 2001	Change 10 01 September 2006
Change 5 24 January 2002	Change 11 20 June 2008

TOTAL NUMBER OF PAGES IN THIS PUBLICATION IS 245, CONSISTING OF THE FOLLOWING:

Page No.	*Change No.	Page No.	*Change No.	Page No.	*Change No.
Cover	0	B-6	0	E-78 thru E-80	7
a and b	11	B-7	7	E-81 and E-82	2
A	11	B-8 thru B-12	11	E-83 and E-84	0
B	0	B-13 and B-14	0	E-85 and E-86	4
i thru vi	11	C-1 thru C-14	0	E-86.1 and E-86.2	4
1-1 and 1-2	0	D-1 thru D-8	0	E-87 thru E-99	0
2-1 thru 2-4	0	E-1 thru E-3	11	E-100	10
3-1 and 3-2	0	E-4 thru E-8	0	E-100.1 and E-100.2	10
3-3 and 3-4	4	E-9	11	E-101 thru E-108	0
3-4.1 and 3-4.2	4	E-10 thru E-20	0	F-1 thru F-6	0
3-5	0	E-20.1 and E-20.2	1		
3-6	7	E-20.3 and E-20.4	11		
3-7	0	E-21 and E-22	0		
3-8 thru 3-10	4	E-23 and E-24	7		
3-10.1 and 3-10.2	4	E-24.1 and E-24.2	7		
3-11 and 3-12	4	E-24.3 and E-24.4	11		
4-1	0	E-25 thru E-32	0		
4-2	11	E-33	9		
4-3 thru 4-4	0	E-34 thru E-47	0		
4-5 and 4-6	4	E-48	4		
4-7 and 4-8	0	E-48.1	4		
4-9 and 4-10	4	E-48.2	7		
4-11 and 4-12	0	E-49 thru E-58	0		
4-13 thru 4-15	4	E-58.1	10		
4-16 thru 4-23	0	E-58.2 thru E-58.4	9		
4-24	4	E-59 thru E-69	0		
4-24.1 and 4-24.2	4	E-70	6		
4-25 thru 4-33	0	E-70.1	10		
4-34 thru 4-38	7	E-70.2	6		
4-39 and 4-40	11	E-71 and E-72	0		
A-1 and A-2	0	E-73	7		
B-1	0	E-74	0		
B-2	8	E-74.1	11		
B-2.1 and B-2.2	1	E-74.2	10		
B-3 and B-4	9	E-75 and E-76	0		
B-5	11	E-77	11		

*Zero in this column indicates an original page

THIS PAGE INTENTIONALLY LEFT BLANK

TECHNICAL MANUAL

No. 9-1300-251-34&P

**HEADQUARTERS
DEPARTMENT OF THE ARMY
Washington, DC, 15 December 1994**

**Direct Support and General Support Maintenance Manual
(Including Repair Parts And Special Tools List)
for
Artillery Ammunition for Guns, Howitzers, Mortars,
Recoilless Rifles and 40mm Grenade Launchers**

REPORTING ERRORS AND RECOMMENDING IMPROVEMENTS

You can help improve this manual. If you find any mistakes or if you know of a way to improve the procedures, please let us know. Mail your letter or DA Form 2028 (Recommended Changes to Publications and Blank Forms) located in the back of this manual directly to Logistics Research and Engineering Directorate (AMSRD-AAR-EIL-LS), U.S. Army RDECOM, Armament Research, Development and Engineering Center, Picatinny Arsenal, NJ 07806-5000. You may also send in your recommended changes via electronic mail or by fax. Our e-mail address is PICAPubChanges@conus.army.mil. Our fax number is DSN 880-4633, Commercial (973) 724-4633. A reply will be furnished to you.

Page

CHAPTER 1.	INTRODUCTION	1-1
Section I.	General	1-1
	1-1 Scope	1-1
	1-2 Forms, Records, and Reports	1-1
Section II.	Description and Data	1-1
	1-3 General	1-1
Section III.	Safety, Care, and Handling	1-1
	1-4 General	1-1
CHAPTER 2.	TOOLS AND EQUIPMENT	2-1
	2-1 General	2-1
	2-2 Repair Parts and Special Tools	2-1
	2-3 Fabricated Tools and Equipment	2-1
	2-4 Special Handling Equipment for Ammunition	2-4
CHAPTER 3.	INSPECTION REQUIREMENTS	3-1
Section I.	General	3-1
	3-1 Purpose of Inspection	3-1
	3-2 Ammunition Surveillance Program	3-1
	3-3 Inspections	3-1
	3-4 Inspection Methods	3-1
	3-5 Extent of Inspection	3-2

* This manual supercedes TM 9-1300-251-34, dated 30 January 1975, including all changes.

Section II.	Classification of Material Defects	3-2
	3-6 General.	3-2
	3-7 In Process and Final Inspection	3-2
	3-8 Disposition of Lots.	3-2
CHAPTER 4.	MAINTENANCE PROCEDURES	4-1
Section I.	Introduction.	4-1
	4-1 General.	4-1
	4-2 Direct Support Maintenance	4-1
	4-3 General Support Maintenance	4-1
	4-4 Unpacking and Repacking	4-1
	4-5 Inspection.	4-1
Section II.	Cleaning	4-2
	4-6 General	4-2
	4-7 Procedure	4-2
	4-8 Grounding of Ammunition	4-3
Section III.	Repair	4-4
	4-9 Packaging Material	4-4
	4-10 Propelling Charges.	4-6
Section IV.	Replacement of Artillery Ammunition Components	4-8
	4-11 General.	4-8
	4-12 Nose Fuzes, Closing Plugs, and Eyebolt Lifting Plugs	4-8
	4-13 Propelling Charges.	4-9
	4-14 Supplementary Charges	4-9
	4-15 Burstern (GS Level Only)	4-10
Section V.	Touch-up, Painting, and Marking	4-11
	4-16 Touchup	4-11
	4-17 Touchup of 120MM Combustible Cartridge Case.	4-12
	4-18 Painting	4-14
	4-19 Color Coding of Boxes with Light Loads	4-19
	4-20 Marking	4-19
Section VI.	Maintenance of Copperhead Items	4-26
	4-21 M172 and M823 Projectiles.	4-26
	4-22 Metal Containers	4-26
	4-23 Pallets.	4-26
Section VII.	Procedure for Windshield Tip Inspection for Cartridge 120MM M829 and M829A1	4-26
	4-24 Windshield Tip Runout Gaging/Acceptance Gaging for Cartridge M829	4-26
Section VIII.	Procedure for Using 120MM Ring Gages	4-29
	4-25 120MM Ring Gages.	4-29
Section IX.	Procedure for Using 120MM Man Portable Chamber Gage (MPCG).	4-34
	4-26 120MM Tank Ammunition	4-34
Section X.	Alignment Criteria and Procedure for M829A1	4-37
	4-27 120MM Cartridge, M829A1	4-37
Section XI.	Projectile Alignment Accept/Reject Criteria for M1028	4-39
	4-28 Alignment Criteria for M1028 Projectile.	4-39

	<u>Page</u>
APPENDIX A. REFERENCES	A-1
APPENDIX B. DIRECT SUPPORT AND GENERAL SUPPORT, PACKING MATERIALS, ACCESSORIES, AND TOOLS	B-1
APPENDIX C. DIRECT SUPPORT AND GENERAL SUPPORT, MAINTENANCE REPAIR PARTS AND SPECIAL TOOLS LIST	C-1
APPENDIX D. EXPENDABLE AND DURABLE ITEMS LIST	D-1
APPENDIX E. MARKING FOR CARTRIDGES AND PROJECTILES	E-1
APPENDIX F. SPECIAL HANDLING EQUIPMENT FOR AMMUNITION.	F-1

LIST OF ILLUSTRATIONS

<u>Figure</u>	<u>Title</u>	<u>Page</u>
2-1	Lifting plug-torque wrench adapter	2-2
2-2	Improvised painting rack for fixed ammunition	2-3
4-1	Marking on fiber containers.	4-20
4-2	Marking on propelling charge container	4-21
4-3	Marking on metal packing box	4-22
4-4	Marking on wooden packing box.	4-23
4-4.1	Palletizing (wood pallet)	4-24
4-5	Palletizing.	4-24.1
4-5.1	Palletizing (FAPP) - metal pallet	4-24.2
4-6	Marking on copperhead metal containers	4-25
4-7	Cartridge M829 tip acceptance gage, flush pin type	4-28
4-8	Obturator ring gage	4-30
4-9	Bourellet ring gage.	4-31
4-10	Case ring gage	4-33
4-11	MPCG base stand.	4-34
4-12	Cartridge, 120mm KE/HEAT Bourellet diameter.	4-35
4-13	Man portable chamber gage (MPCG)	4-36
4-14	Sabot/windshield marking schemes.	4-38
4-15	Acceptable cartridge for M1028	4-38.1
4-16	Unacceptable cartridge for M1028	4-38.1
E-1	Typical marking for 35mm TPT cartridge M968	E-4
E-2	Typical marking for 40mm grenade cartridges M381, M382, M386, M406, M407 and M441 series.	E-5
E-3	Typical marking for 40mm grenade cartridge M433.	E-6
E-4	Typical marking for 40mm grenade cartridge M651.	E-7
E-5	Typical marking for 40mm grenade cartridge M585.	E-8
E-6	Typical marking for 40mm grenade cartridges M583A1, M661, M662, and M992.	E-9
E-7	Typical marking for 40mm grenade cartridges M713, M715, and M716	E-10
E-8	Typical marking for 40mm grenade cartridge M576.	E-11
E-9	Typical marking for 40mm grenade cartridges M674 and M675	E-12
E-10	Typical marking for 40mm grenade cartridges M383, M384, and M684	E-13
E-11	Typical marking for 40mm grenade cartridge M430.	E-14
E-12	Typical marking for 40mm grenade cartridge M918.	E-15
E-13	Typical marking for 40mm grenade cartridge M385.	E-16
E-14	Typical marking for 40mm cartridge M81A1	E-17

LIST OF ILLUSTRATIONS - Continued

<u>Figure</u>	<u>Title</u>	<u>Page</u>
E-15	Typical marking for 40mm gun cartridges Mk2, M25, and M91	E-18
E-16	Typical marking for 60mm mortar cartridges M302 series	E-19
E-17	Typical marking for 40mm gun cartridges M811, M813, M822, and M851 (SGT YORK).	E-20
E-17.1	Typical marking for 40mm dummy cartridge M922	E-20.1
E-17.2	Typical marking for 40mm dummy cartridge M922A1	E-20.2
E-17.3	Typical marking for 40mm grenade cartridge MK281 MOD 0.	E-20.3
E-17.4	Typical marking for 40mm grenade cartridge M1001.	E-20.4
E-18	Typical marking for 60mm mortar cartridges M83 series	E-21
E-19	Typical marking for 60mm mortar cartridges M49, M50 series, and M720.	E-22
E-20	Typical marking for 60mm mortar cartridge XM721	E-23
E-21	Typical marking for 60mm mortar cartridge XM722	E-24
E-21.1	Typical marking for 60mm mortar cartridges M720A1 and M768.	E-24.1
E-21.2	Typical marking for 60mm mortar cartridge M769.	E-24.2
E-21.3	Typical marking for 60mm mortar cartridge M1061.	E-24.3
E-22	Typical marking for 81mm mortar cartridges M362 series, M370, and M445	E-25
E-23	Typical marking for 81mm mortar cartridges M374 series and M375 series	E-26
E-24	Typical marking for 81mm mortar cartridge XM879	E-27
E-25	Typical marking for 81mm mortar cartridges M301 series	E-28
E-26	Typical marking for 81mm mortar cartridges M57 series	E-29
E-27	Typical marking for 81mm mortar cartridges M821 series	E-30
E-28	Typical marking for 81mm mortar cartridges M889 series	E-31
E-29	Typical marking for 81mm mortar cartridges M23 series (HE and TP)	E-32
E-30	Typical marking for 84mm launcher cartridges M136 (AT4) and AT4 CS RS	E-33
E-31	Typical marking for 90mm gun cartridge M580	E-34
E-32	Typical marking for 90mm gun cartridges M77, M318, and M353 series	E-35
E-33	Typical marking for 90mm gun cartridge M332A1.	E-36
E-34	Typical marking for 90mm gun cartridges M313 series	E-37
E-35	Typical marking for 90mm gun cartridges M71 series	E-38
E-36	Typical marking for 90mm gun cartridge M82	E-39
E-37	Typical marking for 90mm gun cartridge M348A1.	E-40
E-38	Typical marking for 90mm gun cartridges M431 series	E-41
E-39	Typical marking for 90mm gun cartridges M336 and M377.	E-42
E-40	Typical marking for cartridge case on 90m gun cartridge M431A2	E-43
E-41	Typical marking for cartridge case on 90mm rifle cartridge M371A1	E-44
E-42	Typical marking for 90mm rifle cartridge M590.	E-45
E-43	Typical marking for 90mm rifle cartridges M371 series	E-46
E-44	Typical marking for 105mm howitzer cartridge M913	E-47
E-44.1	Typical marking for 105mm howitzer cartridge M927	E-48
E-45	Typical marking for cartridge case on 105mm howitzer round M1	E-48.1
E-46	Typical marking for projectile of 105mm howitzer cartridge XM629	E-49
E-47	Typical marking for projectile of 105mm howitzer cartridge M546.	E-50
E-48	Typical marking for projectile of 105mm howitzer cartridge M327.	E-51
E-49	Typical marking for projectile of 105mm howitzer cartridges M60 series and M84 series	E-52
E-50	Typical marking for projectiles of 105mm howitzer cartridges M1, M67, M413, and M444	E-53
E-51	Typical marking for projectiles of 105mm howitzer cartridges M314 series	E-54
E-52	Typical marking for projectile of 105mm howitzer cartridge M548.	E-55
E-53	Typical marking for 105mm gun cartridge DM128.	E-56
E-54	Typical marking for 105mm gun cartridge XM49E3	E-57
E-55	Typical marking for 105mm gun cartridges M393 series, M416, and M417	E-58

LIST OF ILLUSTRATIONS - Continued

<u>Figure</u>	<u>Title</u>	<u>Page</u>
E-55.1	Typical marking for 105mm gun cartridge, M1040	E-58.1
E-55.2	Typical marking for 105mm gun cartridge, M393A3	E-58.2
E-55.3	Typical marking for 105mm gun cartridge, M467A1	E-58.3
E-56	Typical marking for 105mm gun cartridges M392 and M724 series	E-59
E-57	Typical marking for 105mm gun cartridges M735, M774, M833, and M900	E-60
E-58	Typical marking for 105mm gun cartridges M456 series and M490	E-61
E-59	Typical marking for cartridge case 105mm gun cartridges M456 series.	E-62
E-60	Typical marking for 4.2-in. mortar cartridges M2, M630, and M328A1	E-63
E-61	Typical marking for 4.2-in. mortar cartridges M3 series, M329 series, and M335A2	E-64
E-62	Typical marking for cartridge case on 106mm rifle cartridge M581.	E-65
E-63	Typical marking for 106mm rifle cartridge M346A1	E-66
E-64	Typical marking for 106mm rifle cartridge M344A1	E-67
E-65	Typical marking for 106mm rifle cartridge M581.	E-68
E-66	Typical marking for 120mm gun cartridges M829, M892A1, and M865	E-69
E-67	Typical marking for 120mm gun cartridges M829A2 and M829A3.	E-70
E-67.1	Typical marking for 120mm gun cartridge, HE-OR-T, M908	E-70.1
E-68	Typical marking for 120mm gun cartridge M830	E-71
E-69	Typical marking for 120mm gun cartridge HEAT-MP-T, M830A1.	E-72
E-70	Typical marking for 120mm gun cartridges M831 and M831A1	E-73
E-71	Typical marking for 120mm mortar cartridges M57 series	E-74
E-71.1	Typical marking for 120mm gun cartridge, TPMP-T XM1002	E-74.1
E-71.2	Typical marking for 120mm gun cartridge, Canister M1028.	E-74.2
E-72	Typical marking for 120mm mortar cartridges M68 series	E-75
E-73	Typical marking for 120mm mortar cartridges M91 series	E-76
E-74	Typical marking for 120mm mortar cartridge M933 and M933A1.	E-77
E-75	Typical marking for 120mm mortar cartridge M934 and M934A1.	E-78
E-76	Typical marking for 120mm mortar cartridge M930 and M983	E-79
E-77	Typical marking for 120mm mortar cartridge XM929 and M929.	E-80
E-78	Typical marking for 120mm mortar cartridge M931.	E-81
E-79	Deleted	
E-80	Typical marking for 152mm gun cartridge M625	E-83
E-81	Typical marking for 155mm howitzer projectiles M107, M110 series, and M116 series.	E-84
E-82	Typical marking for 155mm howitzer projectile M804.	E-85
E-82.1	Typical marking for 155mm howitzer projectile M795.	E-86
E-83	Typical marking for 155mm howitzer projectile M804A1	E-86.1
E-84	Typical marking for 155mm howitzer projectile M449A1	E-87
E-85	Typical marking for 155mm howitzer projectile M549.	E-88
E-86	Typical marking for 155mm howitzer projectiles M118 series and M485 series	E-89
E-87	Typical marking for 155mm howitzer projectile M483A1	E-90
E-88	Typical marking for 155mm howitzer projectile M687.	E-91
E-89	Typical marking for 155mm howitzer projectile M692.	E-92
E-90	Typical marking for 155mm howitzer projectile M731.	E-93
E-91	Typical marking for 155mm howitzer projectile M718.	E-94
E-92	Typical marking for 155mm howitzer projectile M741.	E-95
E-93	Typical marking for 155mm howitzer projectile M718A1	E-96
E-94	Typical marking for 155mm howitzer projectile M741A1	E-97
E-95	Typical marking for 155mm howitzer projectile M825.	E-98
E-96	Typical marking for 155mm howitzer projectile M825A1	E-99
E-97	Typical marking for 155mm howitzer projectiles M123 series and M623 series	E-100

LIST OF ILLUSTRATIONS - Continued

<u>Figure</u>	<u>Title</u>	<u>Page</u>
E-98	Typical marking for 175mm gun projectile	E-101
E-99	Typical marking for 8-inch howitzer projectile M106.	E-102
E-100	Typical marking for 8-inch howitzer projectile M404.	E-102
E-101	Typical marking for 8-inch howitzer projectile M509A1	E-103
E-102	Typical marking for 8-inch projectile M650	E-104
E-103	Typical marking for 155mm projectiles M712 and M823 (Copperhead)	E-105
E-104	Typical marking for 155mm howitzer projectile M864.	E-106
F-1	Six legged sling, palletized projectile	F-4
F-2	Single beam, palletized projectile	F-5
F-3	Double beam, palletized projectile.	F-5
F-4	Rigging of 155mm palletized projectile.	F-6
F-5	Rigging of 8-inch palletized projectile	F-6

CHAPTER 1 INTRODUCTION

Section I. GENERAL

1-1. Scope

a. This is one of a series of manuals on maintenance of artillery ammunition for guns, howitzers, mortars, recoilless rifles and 40-MM grenade launchers. Information in this manual is limited to the responsibilities of direct and general support maintenance personnel.

b. Operating instructions and operator-level maintenance are covered in the weapon manuals listed in appendix A. Organizational level maintenance is covered in TM 9-1300-251-20, which also contains the Maintenance Allocation Chart (MAC). Authorized procedures for each level of maintenance, including direct and general support, are specified in the MAC.

1-2. Forms, Records, and Reports

a. Forms generally applicable to units maintaining this materiel are listed in appendix A. A current listing of all forms is maintained in DA Pam 25-30. DA Pam 738-750 contains instructions on applicability and completion of forms.

b. Ammunition Data Cards will be annotated to reflect major maintenance operations in accordance with TM 9-1300-250.

c. A record should be kept of each inspection job undertaken on an Ammunition Condition Report (ACR).

Section II. DESCRIPTION AND DATA

1-3. General

Description and data on this ammunition are contained in TM 9-1300-251-20. Refer to the applicable operator and organizational maintenance manuals for detailed operating instructions.

Section III. SAFETY, CARE, AND HANDLING

1-4. General

a. For general information on safety, care, and handling of ammunition, refer to TM 9-1300-206, TM 9-1300-250, and TM 9-1300-251-20.

b. Specific information on safety, care, and handling is contained in the applicable

operator's and organizational maintenance manuals.

c. Specific safety precautions, warnings, and cautions relating to the maintenance operation are incorporated with the maintenance procedures for the ammunition item.

THIS PAGE INTENTIONALLY LEFT BLANK

CHAPTER 2
TOOLS AND EQUIPMENT

2-1. General

a. Tools and equipment having general application to this materiel and used by direct support and general support organizations are authorized for issue as required by tables of allowances (TA) and tables of organization and equipment (TOE).

b. Tools and equipment required for ammunition maintenance will usually be available in the direct support tool set (SC 4940-95-CL-A11) and the general support shop equipment (SC 4925-95-CL-A03) or another tool set authorized under TOE'S for the organization.

2-2. Repair Parts and Special Tools

Refer to appendix C for the repair parts and special tools list.

2-3. Fabricated Tools and Equipment

a. General. Local fabrication of tools and equipment is only permitted when required to perform an authorized maintenance function. When approved drawings and specifications (see b and c below) are not available, design must meet all safety requirements and be approved by local safety officer.

b. Lifting Ring-Torque Wrench Adapter. Obtain a standard 1-1/4-inch socket, with a 1/2-inch drive and cut out according to figure 2-1.

c. Paint Rack for Fixed Ammunition. Construct an improvised paint rack(s), using sturdy and appropriate materials as described in table 2-1, according to figure 2-2. Use hand- and/or power-saws to cut lumber to specified dimensions.

Table 2-1. Material Required for Painting Rack

Part No.	Quantity Required	Title	Basic size
1	26	Rubber pad.	2-3/4 in. x 1/2 in. x 1/16 in.
2	1	Notched support.	2 x 6, 12 ft long
3	2	Notched support.	2 x 3's, 12 ft long
4	1	Notched support.	2x 4, 12 ft long
5	2	Notched support.	2 X 6's, 12 ft long
6	6	Vertical support.	12x6's, 2 ft 10-1/2 in. long
7	3	Upper support.	
8	6	Angle support.	2 x 6 (see fig. 2-2)
9	3	Base support.	2 x 6's, 5 ft long
10	6	Upright long.	1 x 4's, 2 ft 5-3/4 in. long approx
11	2	Step, long.	2 x 6's, 9 ft 9 in. long approx
12	4	Step, short.	2 x 6's, 4 ft 10 in. long approx
13	1	Stiffener.	2 x 6, 3 ft 8-1/2 in. approx
14	3	Cross support.	1 x 6, 2 ft 7-1/2 in. long approx
15	1	Nailer.	2 x 4, 12 ft long
16	1	Bottom support.	2 x 6, 12 ft long
17	6	Upright, short.	1 x 4's, 2 ft 4-1/8 in. long approx
18	2	Lateral support.	1 x 6's, 12 in. long

NOTE

Six (6) penny nails required when nailing items 9, 14, 17 and 18. Eight (8) penny nails to be used in all other nailing requirements.

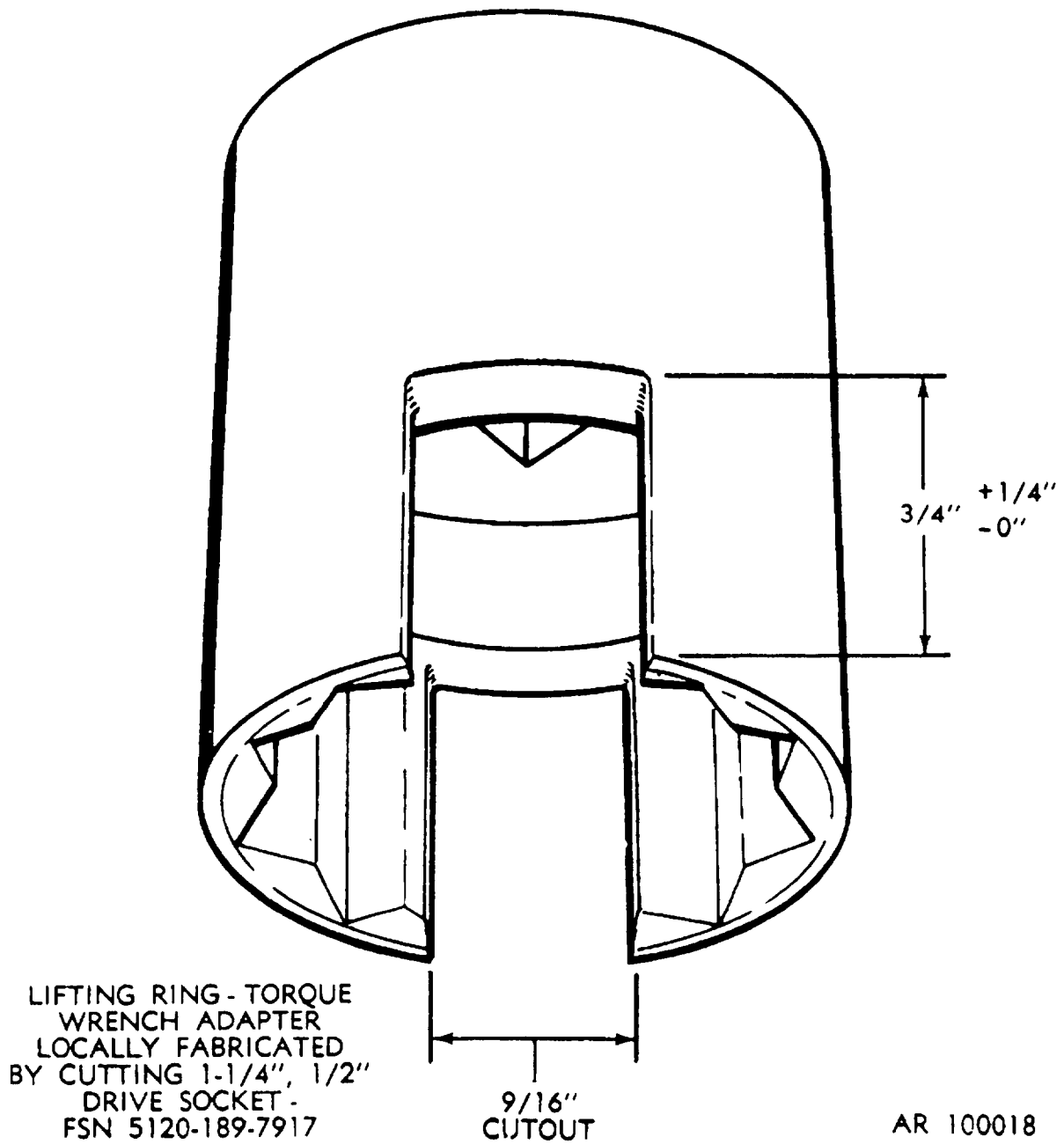
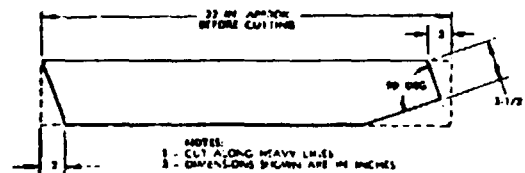
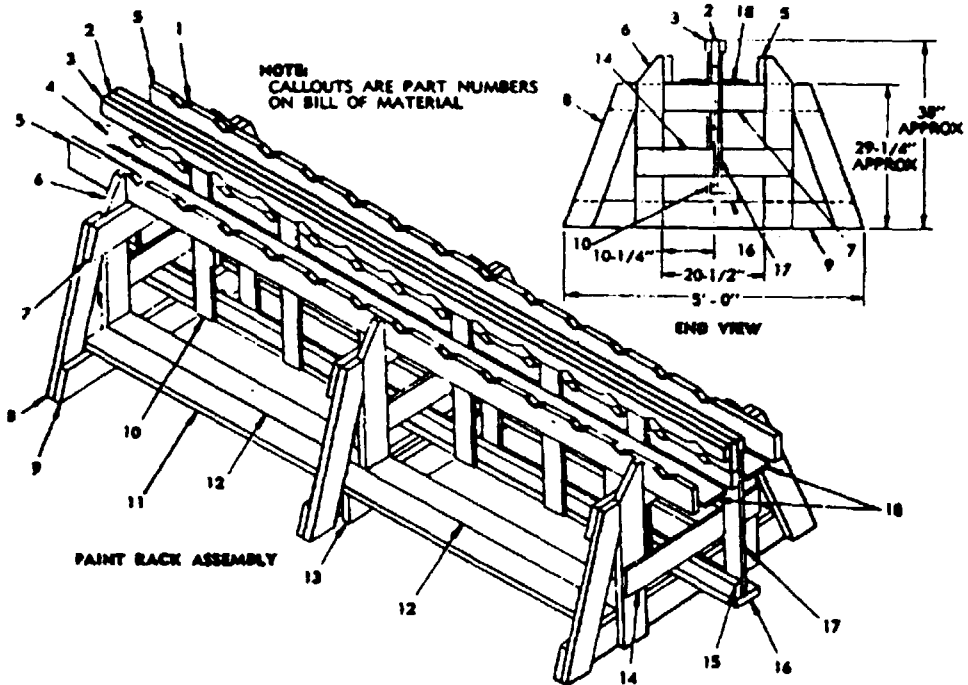
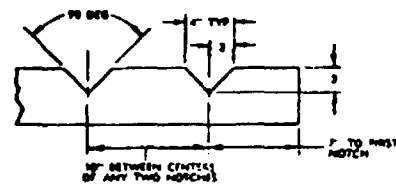

Figure 2-1. Lifting plug - torque wrench adapter.



ANGLE SUPPORT PART NO. 8



DETAIL OF NOTCHES

NOTES:
1 - 12 NOTCHES PROVIDED IN PART NO. 3 AND 3
2 - 14 NOTCHES PROVIDED IN PART NO. 2 AND 2
3 - ALL DIMENSIONS SHOWN ARE IN INCHES

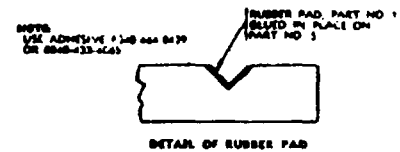

AR 100437

Figure 2-2. Improvised painting rack for fixed ammunition.

2-4. Special Handling Equipment for Ammunition.

Refer to Appendix F for special handling equipment for ammunition.

CHAPTER 3 INSPECTION REQUIREMENTS

Section I. GENERAL

3-1. Purpose of Inspection

a. Inspection criteria contained in this publication are provided to assure that all maintenance performed will restore the item(s) to an acceptable quality level.

b. A complete plan of all maintenance work is required. Prepare Standing Operating Procedures (SOP) that contain detailed production techniques standards, and controls necessary to produce a quality product, See TM 9-1300-250 for planning procedures and SOP preparation.

3-2. Ammunition Surveillance Program

Surveillance includes those actions necessary to evaluate the current degree of serviceability of ammunition, See AR 702-6, AR 740-1, AR 702-12 and SB 742-1 for policy, responsibilities and procedures applicable to the Ammunition Surveillance and Quality Evaluation Program.

3-3. Inspections

a. Serviceability

(1) Ammunition items will be inspected by a Quality Assurance Specialist (Ammunition) or a MOS 055X40 under the guidance of a Quality Assurance Specialist (Ammunition) to determine serviceability or unserviceability according to SB 742-1 and other pertinent SB's.

(2) Required maintenance for unserviceable materiel will be indicated on the inspection report.

b. Pre-Maintenance. At the unpack operation, prior to rework, ammunition items will be screened 100 percent. DS and/or GS personnel will perform screening, which will include the following.

(1) All items with critical non-functional defects will be separated from the quantity to be maintained and disposed of as directed in the SOP.

(2) All items with defects, as listed in table 3-1, will be corrected during maintenance.

(3) Other evidence of poor workmanship or defects that could cause accelerated deterioration or adversely affect the function of the items will be corrected.

c. In-Process.

(1) In-process inspections are an integral part of the maintenance procedures to assure that previous work is adequate and acceptable prior to proceeding with further operations.

(2) Since these inspections are part of the maintenance procedures contained in paragraph 4-1 through 4-19 they will not be specifically covered in this chapter.

d. Final Acceptance.

(1) Ammunition items will be inspected after maintenance has been completed. The final acceptance inspection will determine whether or not maintenance accomplished has returned unserviceable munitions to an acceptable condition.

(2) Quality Assurance Specialist (Ammunition) or MOS 055X40 personnel under the guidance of a Quality Assurance Specialist (Ammunition) will perform this inspection prior to returning the materiel to its storage area.

3-4. Inspection Methods

a. Visual Inspection. Careful observation of item, noting listed defects and any other abnormalities.

b. Manual Inspection. Movement by hand of specified area of item to determine if listed defect(s) exists (e.g., incorrect loose part).

c. Gage Inspection. Checking an item with a measuring instrument or a standard mating piece to determine if its size is acceptable in certain critical areas. Defects are derived from either predetermined standards or on a "go" - "no go" basis (e.g., a ring gage).

3-5. Extent of Inspections

a. Sealed Packages. During serviceability inspections, items packed in harrier bags, jungle wrap, or sealed cans should not be opened for inspection unless sealed package has been opened or there is specific reason to suspect damage. Therefore, sealed packages will usually be subjected only to visual inspection.

NOTE

Manufacturer's Identification and year of manufacture will be embossed on container. If the container has been reconditioned, the words "REHAB," month and year of reconditioning, and activity performing reconditioning will be stenciled on the container.

Section II. CLASSIFICATION OF MATERIAL DEFECTS

3-6. General

Ammunition and packaging defects are listed in table 3-1. This table also provides the methods of inspection and categories of defects. Categories of defects are defined in SB 742-1 An Acceptable Quality Level (AQL) established for each defect is provided in table 3-1 for evaluation during final acceptance inspection.

3-7. In-Process and Final Inspection

a. All items (ammunition and packing materials) processed will be subject to in-process and final inspection to assure acceptability.

b. In-process and final inspections will be included as an integral part of all maintenance procedures.

3-8. Disposition of Lots

a. Each lot that meets the acceptable quality level (AQL) in table 3-1 is acceptable for issue and use. Critical defective(s) will be removed from otherwise acceptable lots and destroyed.

b. Disposition of mortar ammunition with missing or broken safety pin or clip on fuze is immediate local destruction.

c. Lots found with defects will be inspected 100 percent and reworked within the capability

b. Processed Items. All processed items will be subjected to in-process inspections and a final acceptance inspection.

c. Protective Lifting Plug. Because of the break away features of the M549/M549A1 Projectile Lifting Plug, special attention must be observed to see if lower portion of the plug is in the Projectile fuze well.

d. Metal Container (Copperhead).

(1) If only the outside of the container is involved (container touchup, painting, marking, or replacement of rope handles is required), the container need not be opened.

(2) In all other cases, the container will be opened and the contents inspected.

of the unit, as specified in the Maintenance Allocation Chart (MAC). If required maintenance is beyond the capability of the unit, request disposition instructions through ammunition maintenance channels.

d. Any maintenance operation which results in a change to the information on the Lot Ammunition Data Card requires the addition of an alphabetic suffix to the lot number, Lot suffixes for each lot or operation will be obtained through ammunition maintenance channels.

e. Metal Container and Pallet (Copperhead).

(1) Metal containers will be inspected, touched up, repainted, and repaired as specified in the Maintenance Allocation Chart (MAC), and/or stored for reissue. Pallets will be inspected, repaired if possible) and stored.

(2) If any repairable defects are found in containers beyond those authorized for repair at DS/GS level, forward item to Depot for service.

(3) If any irreparable defects are found in containers, disposal instructions will be requested.

(4) Unserviceable pallets may be locally destroyed.

Table 3-1. Classification of Material Defects

GENERAL PACKAGING

Component	Category	Defect	Method of Inspection	Reference	AQL
Outer container	Major	Damaged, weathered, or rotted to extent contents are not protected or container is no longer structurally sound.	Visual	TM9-1300-251-20&P Chapter 3	0.40
	Major	Container cap or closure insecure to extent contents are not protected.	Visual/ Manual	TM9-1300-251-20&P Chapter 3	0.40
	Major	Contents loose to extent item may be damaged in handling.	Visual/ Manual	TM9-1300-251-20&P Chapter 3	0.40
	Minor	Hardware or banding loose, missing, broken or ineffective.	Visual/ Manual	TM9-1300-251-20&P Chapter 3	0.65
	Minor	Handle or cleat missing or broken.	Visual	TM9-1300-251-20&P Chapter 3	0.65
Inner container	Major	Damaged to extent contents are not protected or cannot be readily accessed.	Visual/ Manual	TM9-1300-251-20&P Chapter 3	0.40
	Major	Barrier bag improperly sealed, torn, cut, or otherwise penetrated.	Visual	Refer to Chapter 4	0.40
	Minor	Wet (except metal), rusted, moldy, or mildewed.	Visual	TM9-1300-251-20&P Chapter 3	0.65
	Minor	Barrier bag edges delaminating but not yet unsealed	Visual	Refer to Chapter 4	0.65
WOODEN PALLETS, WOODEN BOXES AND CRATES					
Hardware	Minor	Inoperative or loose.	Visual/ Manual	TM9-1300-251-20&P Chapter 3	0.65
	Minor	Nails, screws, and fasteners which can be replaced or properly sealed.	Visual	TM9-1300-251-20&P Chapter 3	0.65
Ends	Major	Damage which requires disassembly of box.	Visual	TM9-1300-251-20&P Chapter 3	0.40
	Minor	Broken or missing cleats and handles.	Visual	TM9-1300-251-20&P Chapter 3	0.65
Wood	Major	Splits closer than 1 inch to edge of board, or adjoining split or over 1/8-inch.	Visual	TM9-1300-251-20&P Chapter 3	0.40
	Major	Warping which prevents insertion or removal of rounds and/or sealing of the box.	Visual/ Manual	TM9-1300-251-20&P Chapter 3	0.40
	Major	Excessive mildew and mold which cannot be removed and which render markings illegible.	Visual	TM9-1300-251-20&P Chapter 3	0.40
	Major	Holes or loose knots which exceed 1-1/2 in. in largest diameter or 1/3 width of board.	Visual	TM9-1300-251-20&P Chapter 3	0.40
	Major	Knots greater than 1/4 the width of the skid.	Visual	TM9-1300-251-20&P Chapter 3	0.40
	Minor	Splits over 3 inches but no closer than 1 in. to edge of board or adjoining split; or 1/8 inch wide, which can be repaired by the use of corrugated fasteners.	Visual	TM9-1300-251-20&P Chapter 3	0.65
	Minor	Loose skids.	Visual	TM9-1300-251-20&P Chapter 3	0.65

Table 3-1. Classification of Material Defects - Continued

WOODEN PALLETS, WOODEN BOXES AND CRATES - Continued

Component	Category	Defect	Method of Inspection	Reference	AQL
Strapping	Minor	Missing, rusted, or distorted.	Visual	TM9-1300-251-20&P Chapter 3	0.65
Wires	Major	Broken or rusted through.	Visual	Refer to Chapter 4	0.40
Marking	Major	Incorrect and/or illegible.	Visual	Refer to Chapter 4	0.40
Nailing (Pallets only)	Major	Missing or loose nails.	Visual	Refer to Chapter 4	0.40
Metal ends	Major	Perforations, excessive rust, or ends which are crushed or not securely crimped to body.	Visual	TM9-1300-251-20&P Chapter 3	0.40
Body and cap	Major	Cuts, tears, or gouges closer than 1 in. to closure, more than 1/2 square inch in area, or through all impregnated layers.	Visual	TM9-1300-251-20&P Chapter 3	0.40
	Major	Molded, mildewed, or rotted.	Visual	TM9-1300-251-20&P Chapter 3	0.40
	Major	Wrinkled or peeling.	Visual	TM9-1300-251-20&P Chapter 3	0.40
	Major	Blisters with combined area of more than 1/2 square inch.	Visual	TM9-1300-251-20&P Chapter 3	0.40
	Major	Wet or soft containers.	Visual/ Manual	TM9-1300-251-20&P Chapter 3	0.40
	Minor	Cuts, tears, or gouges not closer than 1 inch to closure, less than 1/2 square inch in area, and unpenetrated layers which can be spot painted.	Visual	Refer to Chapter 4	0.65
Marking	Major	Incorrect and/or illegible.	Visual	Refer to Chapter 4	0.40

FIELD ARTILLERY PROJECTILE PALLET (FAPP) - METAL

Latch-rod Assembly	Major	Rod not threaded properly into stud.	Visual/ Manual	TM9-1300-251-20&P Chapter 3	Level III
	Major	Part missing or incorrectly assembled.	Visual	TM9-1300-251-20&P	Level III
	Minor	Protective coating missing.	Visual	Refer to Chapter 4	Level V
Base Assembly	Major	Weld missing or incomplete.	Visual	TM9-1300-251-20&P Chapter 3	Level III
	Minor	Protective coating missing.	Visual	Refer to Chapter 4	Level V
Cover Assembly	Major	Part missing or incorrectly assembled.	Visual	TM9-1300-251-20&P	Level III
	Major	Weld missing or incomplete.	Visual	TM9-1300-251-20&P	Level III
	Minor	Protective coating missing.	Visual	Refer to Chapter 4	Level V
Spacer	Major	Drain slots on bottom of spacer missing.	Visual	TM9-1300-251-20&P Chapter 3	Level V

Table 3-1. Classification of Material Defects - Continued

FIELD ARTILLERY PROJECTILE PALLET (FAPP) - METAL - Continued

Component	Category	Defect	Method of Inspection	Reference	AQL
Latch-Handle Assembly	Major	Latch, when in closed position, does not engage (in hole) completely.	Manual	TM9-1300-251-20&P Chapter 3	Level II
	Major	Part missing or incorrectly assembled.	Visual	TM9-1300-251-20&P Chapter 3	Level III
Pallet Assembly	Minor	Protective finish missing, incorrect, or incorrectly applied.	Visual	Refer to Chapter 4	Level V

METAL CONTAINERS

Body	Major	Dents which impair the structural integrity of the material.	Visual	TM9-1300-251-20&P Chapter 3	0.40
	Major	Loose or leaking seams.	Visual	TM9-1300-251-20&P Chapter 3	0.40
	Major	Rust which has caused pitting and perforations.	Visual	TM9-1300-251-20&P Chapter 3	0.40
	Major	Perforated.	Visual	TM9-1300-251-20&P Chapter 3	0.40
	Major	Damaged supports which are integral to container.	Visual	TM9-1300-251-20&P Chapter 3	0.40
	Minor	Dents deeper than 1/4 inch which may be removed without weakening structure of container.	Visual	TM9-1300-251-20&P Chapter 3	0.65
	Minor	Minor rust which can be removed.	Visual	Refer to Chapter 4	0.65
	Minor	Supports which can be replaced.	Visual	TM9-1300-251-20&P Chapter 3	0.65
Caps and Covers	Major	Rust which has caused excessive pitting.	Visual	TM9-1300-251-20&P Chapter 3	0.40
	Major	Perforated.	Visual	TM9-1300-251-20&P Chapter 3	0.40
	Minor	Minor rust which can be removed.	Visual	Refer to Chapter 4	0.65

THIS PAGE INTENTIONALLY LEFT BLANK

Table 3-1. Classification of Material Defects - Continued

METAL CONTAINERS - Continued					
Component	Category	Defect	Method of Inspection	Reference	AQL
Marking	Major	Incorrect and/or illegible.	Visual	Refer to Chapter 4	0.40
METAL BOXES					
Body and Cover	Major	Extensive pitting and rust.	Visual	TM 9-1300-251-20 Chapter 3	0.40
	Major	Split seams.	Visual	TM 9-1300-251-20 Chapter 3	0.40
	Major	Dents, which cause creases or folds in metal which cannot be removed.	Visual	TM 9-1300-251-20 Chapter 3	0.40
	Major	Perforated.	Visual	TM 9-1340-222-20	0.40
	Major	Missing or broken separators.	Visual	TM 9-1340-251-20 Chapter 3	0.40
	Minor	Minor rust which can be removed.	Visual	para 4-6	0.65
	Minor	Dents exceeding 4 sq. in. per side, end, or top or deeper than 1/4 in.	Visual	TM 9-1300-251-20 Chapter 3	0.65
Minor	Damaged or missing gaskets.	Visual	TM 9-1300-251-20 Chapter 3	0.65	
Marking	Major	Incorrect and/or illegible.	Visual	para 4-20	0.40
FIXED AMMUNITION (EXCEPT 152MM)					
Projectile	Critical	Distorted or out-of-round projectile.	Gage		1.00
	Critical	Exudation of filler around fuze well.	Visual		1.00
	Major	Corrosion in nose of fuze well or supplementary charge.	Visual		0.40
	Major	Rust or corrosion at bourrelet.	Visual		0.40
Major	Damaged rotating band.	Visual		0.40	
Projectile, Projectile, Spoiler		Damaged, bent.	Visual		0.40
	Major	Missing, bent, or damaged.	Visual		0.40
Fuze	Major	Corrosion on nose fuze body (See Nose Fuzes for additional defects),	Visual		0.40
Cartridge case	Critical	Cracked or split cartridge case.	Visual		1.00
	Critical	Unravalled to extent propellant can escape (spiral wrap cartridge case).	Visual		1.00
	Critical	Liner of 106mm recoilless rifle cartridge damaged to extent that propellant can escape.	Visual		1.00
	Major	Corrosion on cartridge case and/or primer.	Visual		0.40
	Major	Severe cartridge case dents,	Visual		0.40
Major	Liner of 106mm recoilless rifle cartridge case damaged but not to the extent that propellant can escape.	Visual		0.40	
Major Marking	Major	Incorrect and/or illegible.	Visual	-	0.40

Table 3-1. Classification of Material Defects - Continued

FIXED AMMUNITION (EXCEPT 152MM) - Continued

Component	Category	Defect	Method of Inspection	Reference	AQL
Projectile HEAT-MP-T and TP-T	Major	Damage preventing chambering.	Visual/ Gage	-	1.00
Spike - TP	Major	a. Missing or damaged Spike tip.	Visual	-	1.00
	Major	b. Disc around tip missing or damaged.	Visual	-	0.40
	Major	c. Stamped arrows missing.	Visual	-	1.00
-HEAT	Major	Flange on spike tip damaged or distorted	Visual	-	1.00
Shoulder Switch	Major	Loose, bent or cracked.	Visual	-	1.00
Copper Band	Major	Missing or damaged.	Visual	-	1.00
Projectile Rubber Seal Projectile APFSDS-T	Major	Split, torn or piece missing.	Visual	-	0.40
Windshield Tip	Major	Bent or tip loose.	Visual/ Gage	-	1.00
Windshield	Major	Presence of DU corrosion (yellowish/black powder or staining evident) in sabot/windshield interfaces.	Visual	-	1.00
	Major	Multiple cracks or cracks in excess of 2 inches. (M829)	Visual/ Manual	-	0.40
	Minor	Longitudinal crack 2 inches or less in length. (M829)	Visual/ Manual	-	1.00
Sabot Segments	Major	DU corrosion (yellowish black powder or staining evident) in sabot gaps; sabot/windshield interface.	Visual/ Swipe	-	0.40
	Major	Cracked.	Visual	-	
	Major	Movement between penetrator and sabot.	Manual	-	0.40
FIXED AMMUNITION (120MM TANK AMMO ONLY)					
Forward nylon retaining band	Major	Missing.	Visual	-	1.00
	Minor	Broken or gouged.	Visual	-	0.40
Rear nylon seal	Major	Broken or missing.	Visual	-	1.00
	Minor	Gouged.	Visual	-	0.40
Rubber seal	Major	Split or piece missing.	Visual	-	1.00
	Minor	Partially torn or gouged.	Visual	-	0.40
Forward bore riding surface	Major	Gouged or burned.	Visual	-	1.00
Projectile	Major	Projectile Loose (rotation relative to case). M830, M831, M865.	Visual/ Manual	-	0.40

Table 3-1. Classification of Material Defects - Continued

FIXED AMMUNITION (120MM TANK AMMO ONLY) - Continued

Component	Category	Defect	Method of Inspection	Reference	AQL
Projectile (Cont)	Minor	Projectile loose (rotation relative to case). M829, M829A1.	Visual/ Manual		1.00
	Inci- dental	Subprojectile (penetrator) loose/ rattles within sabot.	Visual/ Gage		0.40
Combustible Cartridge Case and Cap	Major	Abrasion damage to the cartridge case exposing yellowish/white case material. Damaged area(s) revealing yellowish/white case material totaling 10% (30 in ² , 194 cm ²) less of total cartridge case area.	Visual		0.40
	Major	Damage as in a. above, but 10% or more of case coating,	Visual		1.00
	Major	Case broken exposing propellant,	Visual		1.00
	Major	Yellowish-white case material visible on case shoulder. scratches and/or spots).	Visual		1.00
	Major	Side wall of case revealing spots or scuffed areas of combustible case material. (yellowish-white)	Visual		0.40
	Major	Shoulder and sidewall of case cracked, punctured, dented or split.	Visual		0.40
	Major	Glue joint (connection between case side wall and case cap) partially or fully separated.	Visual		0.40
	Major	Snap joint fully or partially sheared, Shearing is evident by gap between obturator and case adapter (M829 series only).	Visual		0.40
	Major	Moisture contamination (cartridge case soft to the touch and/or swollen).	Visual		0.40
	Inci- dental	Superficial scrapes/marks penetrating outer polyurethane coating but not exposing white case surface.	Visual		0.40
Inci- dental	Scrapes/scratches (pinstripe) on side wall revealing yellowish white case material. No more than 6 scratches per case.	Visual		0.40	
Case Base and Seal	Major	Pulled away from combustible case.	Visual		1.00
	Major	Rubber seal chipped, gouged, or partially torn.	Visual		1.00
	Major	Rubber seal completely torn and/or pulled away from case base.	Visual		1.00
	Major	Base completely separated from combustible case.	Visual		1.00
	Major	Visible water marks (a transition line from a light-colored area to a dark-colored area).	Visual		1.00
	Major	Corrosion on case base/primer causing pitting.	Visual		0.40
	Minor	Corrosion on case base/primer without pitting.	Visual		1.00

Table 3-1. Classification of Material Defects - Continued

SEMI-FIXED AMMUNITION (EXCEPT MORTAR)

Component	Category	Defect	Method of Inspection	Reference	AQL
Projectile	Critical	Distorted or out-of-round projectile.	Gage	-	1.00
	Critical	Exudation of filler around fuze well.	Visual	-	1.00
	Major	Rust or corrosion bourrelet.	Visual	-	0.40
	Major	Corrosion in fuze or on supplementary charge.	Visual	-	0.40
	Major	Damaged rotating band.	Visual	-	0.40
Mortar cartridge	Critical	Missing or broken safety pin or clip on fuze.	Visual	-	-
Inner pack	Major	Jungle wrap cut, penetrated or otherwise unsealed.	Visual	-	100%

152MM AMMUNITION

Projectile	Critical	Distorted or out-of-round projectile.	Gage	-	100%
	Critical	Exudation of filler around fuze well.	Visual	-	100%
	Major	Major rust or corrosion (more than 2 square inches or pits from corrosion) on projectile.	Visual	-	0.40
	Major	Damaged rotating band.	Visual	-	0.40
Fuze	Major	Corrosion on nose fuze body (See Nose Fuze for additional body defects).	Visual	-	0.40
Cartridge Case	Critical	Cartridge case base separated from cartridge case body.	Visual	-	100%
	Critical	Cartridge case separated from projectile (pull back rubber barrier bag to observe junction).	Visual/ Manual	-	100%
	Critical	Loose ignition element.	Visual/ Manual	-	100%
	Major	Cartridge case with open cracks or loosely assembled to projectile.	Visual/ Manual	-	0.40
	Major	Torn or missing rubber barrier bag.	Visual	-	0.40
	Major	Corrosion on ignition element or fuze body.	Visual	-	0.40

SEPARATE-LOADING PROJECTILES (EXCEPT COPPERHEAD)

Projectile	Critical	Distorted or out-of-round body.	Gage	-	100%
	Critical	Exudation of filler.	Visual	-	100%
	Critical	Rust through projectile base plate.	Visual	-	100%
	Critical	Missing rocket motor cap.	Visual	-	100%
	Critical	Damaged (cannot be repositioned to remain in the groove) or missing obturating band, M825/M825A1, M549A1 HERA rounds, and M864 projectiles.	Visual	-	100%
	Critical	Evidence of looseness or excessive gap between warhead and motor body assembly of both 155mm, M549A1 and 8-in., M650 projectiles. Gap criteria for inspection and maintenance is: a. A 0.0075 in. feeler gage shall not enter joint at any point.	Visual/ Gage	-	100%

Table 3-1. Classification of Material Defects - Continued

SEPARATE-LOADING PROJECITLES (EXCEPT COPPERHEAD) - Continued

Component	Category	Defect	Method of Inspection	Reference	AQL
Projectile (Cont)		b. A 0.0035 in. feeler gage may enter joint by more than 1/8 in. on any one 30 degree segment, however, it may not enter by more than 1/8 in. on the remainder 330 degree segment.			
	Critical	Broken lifting plugs-threaded area remains in fuze well of projectile, for M549/M549A1 only.	Visual	-	100%
	Critical	Supplementary charge pad or supplementary charge missing.	Visual	-	100%
	Critical	Liner missing.	Visual	-	100%
	Major	Rust or corrosion over bourrelet.*	Visual	-	0.40
	Major	Corrosion in fuze well or on supplementary charge.	Visual	-	0.40
	Major	Damaged obturating band.	Visual	-	0.40
	Major	Smoke Canister Leaking Powder (Practice projectile only).	Visual	-	0.40
	Major	Gap greater than 0.010 in. at any point between forward and aft warhead assembly of the 8-in., M650.	Gage	-	100%
Major	Perforated basebleed weather seal for M864 only.	Visual	-	100%	
PROPELLING CHARGES					
Propelling Charge	Critical	Missing or broken central igniter tube.	Visual	-	100%
	Critical	Blocked central igniter core.	Visual/ Manual	-	100%
	Critical	Missing or off center base igniter pad or missing igniter core.	Visual	-	100%
	Critical	Missing bag, extra bag, or incorrect sequencing of zones.	Visual	-	100%
	Critical	Missing or loose lacing jacket.	Visual/ Manual	-	100%
	Critical	Tie straps not tied or loosely tied.	Visual/ Manual	-	100%
	Major	Missing flash reducer.	Visual	-	0.40
	Major	Bags(s) torn or damaged to extent that black powder or propellant can escape.	Visual	-	0.40
	Major	Combustible case broken or damaged to extent that propellant can escape.	Visual	-	0.40

See footnotes at end of this table

Table 3-1. Classification of Material Defects - Continued

PROPELLING CHARGES - Continued

Component	Category	Defect	Method of Inspection	Reference	AQL
Propelling Charge (Cont)	Major	Combustible case with cut or puncture through case wall.	Visual	-	0.40
	Major	Combustible case with uneven cap (crooked, titled, or slanted).	Visual	-	0.40
	Major	Combustible case that cannot be repacked into its sleeve due to exterior damage.	Manual	-	0.40
	Major	Deteriorated propellant bag.****	Manual	-	0.40
	Major	Lumpy or caked powder in ignition pad.	Manual	-	0.40
Container	Major	Container damaged to extent that propelling charge cannot be removed.	Manual	-	0.40
	Major	Metal container lid gasket missing, out of damaged or deteriorated.	Visual	-	0.40
	Major	Damaged or deteriorated container with penetration.	Visual	-	0.40

NOSE FUZES

Nose Fuze	Critical	Missing or broken safety pin or clip (howitzer and mortar fuzes only).	Visual	-	100%
	Critical	Loose nose cap (all except M739 Series fuzes).	Visual	-	100%
	Critical	Missing or broken component.	Visual	-	100%
	Critical	Corrosion on time rings.	Visual	-	100%
	Critical	Severe physical damage.	Visual	-	100%
	Critical	Fuze is suspected of being armed.	Visual	-	100%
	Major	Corrosion on fuze body.	Visual	-	0.40
	Major	Loose booster assembly (only for fuzes that are not assembled on rounds).	Manual	-	0.40
	Minor	Loose nose cap (M739 series fuzes only).	Visual	-	100%

BURSTERS (REFPLACEMENT ITEMS ONLY)

Burster	Critical	Explosive and/or exudation.	Visual	-	100%
	Critical	Missing onion skin seal, felt-pad, base plug, or closure.	Visual	-	100%
	Major	Lack of record indicating recently passed 100 percent x-ray inspection (tetytol).	Visual	-	0.40
	Major	Physically damaged case.	Visual	-	0.40

M712 PROJECTILE (COPPERHEAD)

Projectile	Critical	Evidence of leakage of composition B.	Visual	-	100%
	Critical	Cracked or deeply gouged obturator.	Visual	-	100%

See footnotes at end of this table

Table 3-1. Classification of Material Defects - Continued

M712 PROJECTILE (COPPERHEAD) - Continued

Component	Category	Defect	Method of Inspection	Reference	AQL
Projectile (Cont)	Major	Aft closure damaged to extent that it would prevent engagement of extractor.	Visual	-	100%
	Major	Loose splice screws. (A screw is considered loose when the screwhead is higher than the area around it.)	Visual	-	100%
	Major	Loose access cover.	Visual	-	100%
	Major	Broken, cracked, or missing projectile ogive.	Visual	-	100%
	Major	Crack or dent in any part of projectile body.	Visual	-	100%
	Major	Wings or fins are loose or broken or not in retracted position.	Visual/ Manual	-	100%
	Major	Water droplets condensed on, or fogging of, surface of nose cone.	Visual	-	100%
	Major	Window portion of projectile ogive (nose cone) severely scratched or gouged.	Visual	-	100%
	Major	Dirt, debris, or foreign objects in wing or fin slots.	Visual	-	0.40
	Major	Dials on code/time switches missing, broken, or illegible.	Visual	-	100%
	Major	Code/time switches require excessive torque to rotate or seem unusually loose when rotated.	Visual/ Manual	-	100%
	Major	Excessive rust or pitting of bourrelets.	Visual	-	100%

THIS PAGE INTENTIONALLY LEFT BLANK

Table 3-1. Classification of Material Defects - Continued

M712 PROJECTILE (COPPERHEAD) - Continued

Component	Category	Defect	Method of Inspection	Reference	AQL
Projectile (Cont)	Major	Switch bracket broken or damaged.	Visual/Manual	-	100%
	Minor	Minor abrasions or smudges on window portion of projectile ogive.	Visual	-	0.65
	Minor	Partial obliteration of markings.	Visual	-	0.65
	Minor	Scratches in paint and projectile body.	Visual	-	0.65

M823 PROJECTILE (COPPERHEAD)

Projectile	Major	Excessive rust or pitting of bourrelets.	Visual	-	0.40
	Major	Cracked or deeply gouged obturator.	Visual	-	0.40
	Major	Switch bracket broken or damaged.	Visual/Manual	-	0.40
	Major	Dials on code/time switches missing, broken, or illegible.	Visual	-	0.40
	Major	Code/time switches required excessive torque to rotate or seem unusually loose when rotated.	Visual	-	0.40
	Minor	Water droplets condensed on, or fogging of, interior surface of projectile ogive (nose cone).	Visual	-	0.65
	Minor	Dirt, debris, or foreign objects in wing or fin slots.	Visual	-	0.65
	Minor	Window portion of projectile ogive (nose cone) abraded, smudged, scratched, or gouged.	Visual	-	0.65
	Minor	Partial obliteration of markings.	Visual	-	0.65
	Minor	Scratches in paint and projectile body.	Visual	-	0.65

METAL CONTAINER (COPPERHEAD)

Container	Major	Container damaged to extent that it cannot be opened in usual manner.	Visual/Manual	**	100%
	Major	40% dot on humidity indicator is not blue.	Visual	***	100%
	Major	Container damaged to extent that projectile damage would be indicated.	Visual	-	100%
	Major	Damaged, leaking or missing gasket.	Visual	***	100%
	Major	Perforated as result of rust or penetration foreign object.	Visual	-	0.40
	Major	Dents that impair the structural integrity of the container.	Visual	-	0.40

See footnotes at end of this table

Table 3-1. Classification of Material Defects - Continued

METAL CONTAINER (COPPERHEAD) - Continued

Component	Category	Defect	Method of Inspection	Reference	AQL
Container (Cont)	Major	Loose or broken handles.	Visual	-	0.40
	Major	Stiffening ribs damaged to extent that ability to palletized multiple rounds are impaired.	Visual	-	0.40
	Major	Internal pressure pads missing, damaged, or deteriorated.	Visual	***	0.40
	Major	Cradle pads missing, damaged, or loose.	Visual	-	0.40
	Major	Humidity indicator damaged or loose to extent that it would permit leakage.	Visual	***	0.40
	Minor	Minor rust and paint deterioration.	Visual	-	0.65
	Minor	Partially obliterated markings.	Visual	-	0.65
	Minor	Dents and scratches that do not impair mission of container to protect projectile.	Visual	-	0.65
Lifting Straps	Major	Rips in straps. Stitching loose or missing.	Visual	-	0.40
Preload Bands	Major	Missing plastic inserts (preload tabs).	Visual	-	0.40
		Damaged latches.			

*The bourrelet is a finely machined band or ring of metal just behind the ogive of a projectile, and designed to support the front portion of the projectile, riding the lands as it travels through the bore of a gun.

**See TM 9-1300-251-20&P, Chapter 3 and figure 3-20.

***Defect does not apply to container when used for M823 training round.

****Yellow discoloration of charge bags is not a defect, as all M188A1 charges containing stabilizer 2NDPA will discolor.

*****Minor for 829 and M829A1.
Major for M830, M831, and M865.

CHAPTER 4 MAINTENANCE PROCEDURES

Section I. INTRODUCTION

4-1. General

a. Direct support (DS) and general support (GS) maintenance operations are restricted to procedures in this manual and in TM 9-1300-251-20, as indicated in the Maintenance Allocation Chart (MAC).

NOTE

This manual does not contain procedures for projectiles filled with lethal agents. Required procedures are contained in Depot Maintenance Work Requirements (DMWR) when authorized.

b. Repair Parts and Special Tools List and packing materials, accessories, and tools, and expendable supplies (appendices B, C, and D) required by DS and GS units will be locally stocked. DS and GS units are also responsible for receiving and storing packaging materials salvaged from expended ammunition and for providing technical assistance to operator and organizational units.

c. Before beginning maintenance operations, a line layout and standing operating procedures (SOP) are required. Guidelines for organizing the line and writing the SOP are contained in TM 9-1300-250.

d. In general, maintenance operations include but are not limited to:

- (1) Cleaning and preservation of individual items and packaging materials.
- (2) Removal of light rust and corrosion.
- (3) Repair and replacement of packaging materials.
- (4) Painting and marking.

(5) Storage and reissue of Copperhead metal containers and pallets.

(6) Holding of Copperhead M712 projectiles pending disposition instructions.

e. Expendable supplies are listed in appendix D.

4-2. Direct Support Maintenance

a. Direct support maintenance is performed under the following conditions:

- (1) Upon receipt of unserviceable ammunition.
- (2) When maintenance is authorized to correct deficiencies in suspended ammunition lots.
- (3) When operator and/or organizational units request onsite assistance.
- (4) When inspection of on-hand-stocks reveals the need.

b. Refer to FM 9-19 for mission and organization.

4-3. General Support Maintenance

General support maintenance is accomplished under the same conditions (but on larger stocks of ammunition) as direct support maintenance. Refer to FM 9-19 for mission and organization.

4-4. Unpacking And Repacking

Step-by-step unpacking and repacking procedures are given in TM 9-1300-251-20.

4-5. Inspection

Pre-maintenance, in process, and final inspection requirements are defined in paragraphs 3-1 through 3-8.

Section II. CLEANING

4-6. General

WARNING

- DO NOT USE ANY ELECTRICAL EQUIPMENT AROUND AMMUNITION WITH EXPLOSIVE (I.E., A SEMIFIXED CARTRIDGE CASE OR A PROJECTILE WITH AN OPEN FUZEWELL) UNLESS IT HAS A NATIONAL ELECTRICAL CODE RATING OF CLASS I FOR FLAMMABLE VAPOR, CLASS II FOR EXPLOSIVE DUSTS (INCLUDING AMMUNITION), OR IS DUAL RATED IF BOTH VAPOR AND DUSTS ARE PRESENT.
- ALL AMMUNITION CONTAINING EXPLOSIVES MUST BE GROUNDED WHEN BEING WORKED ON (SEE PARA 4-8).
- ASSURE THAT DECK SANDER OR ANY OTHER POWER TOOL BEING USED FOR DERUSTING IS PROPERLY GROUNDED (I.E., PLUGGED INTO A THREE-WIRE SOCKET OR THE THIRD/WIRE IS SECURELY CONNECTED TO A GOOD GROUND (SEE PARA 4-8C).
- USE ONLY NON-SPARKING WIRE BRUSHES ON AMMUNITION—EVEN ON ARTILLERY PROJECTILES WITH FUZEWELLS SEALED WITH A NOSE PLUG. DO NOT USE WIRE BRUSHES ANYWHERE NEAR PRIMER ON REAR OF CARTRIDGE CASES OR ON FUZES.
- ACETONE IS EXTREMELY FLAMMABLE; KEEP AWAY FROM HEAT, SPARKS, AND OPEN FLAMES; KEEP CONTAINER CLOSED; USE ADEQUATE VENTILATION; AND AVOID PROLONGED OR REPEATED CONTACT WITH THE SKIN. THE VAPOR IS HEAVIER THAN AIR AND MAY TRAVEL CONSIDERABLE DISTANCE TO A SOURCE OF IGNITION AND FLASHBACK. ACETONE CAN REACT VIGOROUSLY WITH OXIDIZING MATERIALS.
- NEVER ATTEMPT TO CLEAN THE ELECTRIC PRIMER OF THE CARTRIDGE BY ANY METAL OBJECT OR TOOL.

a. Tools and Equipment.

- (1) Disposable flammable waste can.
- (2) Non-sparking wire brush.
- (3) Plunger type safety can.

b. Expendable Supplies.

- (4) Alcohol.
- (5) Acetone.
- (6) Corrosion removing compound.
- (7) Rags.
- (8) Sandpaper.

4-7. Procedure

WARNING

- FUZE CAVITY LINER MUST BE IN PLACE PRIOR TO CLEANING FUZEWELL OR THREADS WITH SMALL STAINLESS STEEL BRUSH, OR ACETONE DAMPENED RAGS.
 - STORE RAGS IN NONCOMBUSTIBLE SELF-CLOSING CONTAINERS. PLACE WASTES OR USED RAGS IN WATER FILLED CONTAINERS. AREAS WILL BE WELL VENTILATED WHERE SOLVENTS AND PAINTS ARE USED.
- a. Remove dirt, mud and other foreign material using rags or scrub brushes. Use rags dampened with alcohol or acetone to remove grease.

NOTE

Acetone can smear the markings, so keep this solvent away from them if possible.

b. Remove nose plug to clean fuzewell area of artillery projectiles.

- (1) Assure fuzewell liner is properly and securely in place. If it is loose or missing, just clean the area with DRY rags and immediately resecure the nose plug.
- (2) If fuzewell liner is properly in place, acetone dampened" rags and/or the small stainless steel wire brush may be used to clean the area as necessary.

c. Resecure nose plug (para 4-12) before undertaking derusting.

- (1) Ground ammunition item to be derusted (para 4-8).
- (2) Remove flaked, chipped, blistered or peeling paint and light corrosion (rust) from metal surfaces of ammunition using sandpaper, rags, and corrosion removing compound or hand nonsparking wire brushes as necessary. Do not use wire brushes anywhere near primer on rear of cartridge cases or on fuzes.
- (3) Properly grounded powered deck sander with nonsparking wire brush or sanding disc may be used on artillery projectiles whose fuzewells are securely sealed with a nose plug. In the case of semifixed ammunition the cartridge cases must be removed from the area during this operation because the currently provided deck sander is not explosion proof and must never be used around exposed explosives. Do not use this device on primed cartridge cases (including those on fixed ammunition). Be careful not to use disc sander on the projectile rotating band.
- (4) Clean corrosion from aluminum or copper based metals by first brushing with a non-sparking wire brush and then removing residue with rags and corrosion removing compound,
- (5) Clean only to degree necessary to remove bad paint, rust or corrosion. Wipe all derusted surfaces with alcohol dampened rag to remove all residue of the operation.
- (6) Inspect cleaned item for cracks or other damage or deterioration.

(7) Allow solvent-cleaned surfaces to dry thoroughly before painting, (see para 4-16).

d. M712 and M823 projectiles (Copperhead)—refer to TM 9-1300-251-20 for step-by-step cleaning procedures. Observe all cautions.

e. Metal Container (Copperhead) — refer to TM 9-1300-251-20 for step-by-step cleaning procedures.

4-8. Grounding of Ammunition

a. General. Properly ground all ammunition containing explosives when performing any contact type operations (derusting, paint removal, cleaning, etc). Ground ammunition by making a low resistance electrical connection between the item and a metal object known to be grounded. Grounding system must be approved by the local safety officer.

b. Expendable Supplies.

- (1) Abrasive paper (sandpaper).
- (2) Copper wire No. 10.
- (3) Ground rods,
- (4) Electrical clip.

c. Procedure. The general procedure for grounding ammunition is as follows:

- (1) Locate an approved grounded metal object such as a cold water pipe or metal underground telephone line conduit within 25 feet of the work area.
- (2) Clean a small section of the grounded object's surface with sandpaper in order to obtain a good contact.
- (3) If a suitable grounded metal object is not available, hammer a grounding rod into the earth within 25 feet of the work area.
- (4) Cut the required length of No, 10 wire to reach between the item and the grounded object.
- (5) Strip 1 inch of insulation from each end of the wire.
- (6) Attach an electrical clip to each end of wire.

- (7) Clamp one electrical clip to the cleaned grounded object's surface or attach one of the bared ends of wire to the grounding rod clamps.

NOTE

For a more permanent installation, strip enough insulation from wire so that the bared end can be wrapped around the cleaned grounded object's surface at least two and a half times. Secure wire with a hose clamp.

- (8) Carefully attach the other electrical clip to the rotating band of most artillery items. On unfuzed items, where it is impossible or difficult to

attach the electrical clip to the rotating band, sand the paint off the ring of a spare lifting plug. Remove original lifting or closing plug and temporarily install sanded lifting plug. Attach electrical clip to the sanded lifting plug ring.

WARNING

DO NOT REMOVE LIFTING OR CLOSING PLUG AND ATTACH ELECTRICAL CLIP TO THE NOSE AND EXPOSED FUSE WELL OF THE ITEM.

- (9) Reinstall serviceable lifting or closing plug according to para 4-12.

Section III. REPAIR

4-9. Packaging Materials

a. General. Detailed procedures for authorized repair of most packaging materials are given in TM 9-1300-251-20. Procedures authorized at DS or GS level are stated below.

b. Wirebound Box Loops (DS and GS levels).

(1) Tools and equipment.

- (a) Tin snips.
- (b) Pliers.
- (c) Hammer.
- (d) Sallee fastener.

(2) Expendable supplies. Wire.

(3) Procedure. A broken wire loop on a wirebound box may be repaired if both legs of broken loop are securely fastened to box.

- (a) Cut off broken loop even with top edge of box.
- (b) Using pliers, bend remaining wire legs back one-half inch, forming half circles.
- (c) Cut a 6-inch length of wire to replace a broken loop.
- (d) Bend repair wire in half to form U shape. Then bend

about one-half inch of each leg outward about 150°.

- (e) Hook bent legs of repair wire into half circles of box wires.
- (f) Twist ends of repair wire around ends of box wires.
- (g) Place box panel on hard surface or place a steel bar under repair area.
- (h) Secure the repair by hammering the twisted wires together against the box panel.

c. Resealing or Replacement of Barrier Bags GS Level).

(1) Tools and equipment.

- (a) Scissors or knife.
- (b) Heat sealer.

(2) Expendable supplies.

- (a) Barrier material.
- (b) Tape, PPP-T-60.

(3) Procedure. This procedure is basically a repacking procedure but is listed here because it will normally be undertaken on a repair basis. Only items that have been completely inspected and found satisfactory will be resealed.

- (a) Receive bag from unpacking operation. Trim open end straight, if necessary.
- (b) Examine barrier bag and accept or reject as required. Acceptable bags are intact (except for opening slit) and can be resealed after contents are reinserted. If bag corners are delaminated but bag is otherwise intact and can be sealed, use heat sealing machine to re-laminate corners. Set rejects aside for later disposal.
- (c) If markings are obliterated on otherwise undamaged bags, remark as instructed in paragraph 4-18.
- (d) If new bags are required:
 - 1 Cut two sheets of barrier material for each bag to dimensions of original bag.
 - 2 Place two cut sheets of barrier material together, plastic facing plastic, and align.
 - 3 Seal three edges, using heat sealing machine. Leave wider edge open if bag is not square.
- (e) Assure that item to be repacked and packing materials are clean and dry.
- (f) Place item(s) into original inner pack in original manner using all padding materials. Use extra padding materials to fill voids and to prevent item from moving. Tape inner pack to secure it, if necessary.
- (g) Place inner pack in barrier bag in original orientation using creases, etc., as a guide.
- (h) Leaving open end free, flatten bag around inner pack and press sides of open end of bag together to force out excess air.
- (i) Seal open end of bag, using heat sealing machine. Seal fully width of sealing bar. Seal shall be minimum 1/2-inch wide. Check to see that seal is complete.
- (j) Fold sealed end in original manner (indicated by impressions in bag).

d. Metal Container (Copperhead).

- (1) Replacement of rope handles. Follow procedures in TM 9-1300-251-20&P.

- (2) Replacement of humidity indicator card. Check humidity indicator. If 40 percent humidity sector on indicator is not blue, change desiccant and card as follows:
 - (a) Open container, remove desiccant, replace with fresh desiccant, and close container. Follow procedures in TM 9-1300-251-20&P.
 - (b) Using 1-3/8-inch socket and ratchet handle with 3/4-inch square male drive, or slip-joint pliers NSN 5120-00-278-0352, unscrew humidity indicator from the container, turning counterclockwise.
 - (c) Use 1/2-inch socket head screw key (Allen wrench) to unscrew plug from inside of humidity indicator, turning counterclockwise.
 - (d) Remove gasket from inside of humidity indicator.
 - (e) Remove used indicator card. Insert new indicator card.
 - (f) Reinstall gasket inside humidity indicator.

NOTE

If gasket is not reusable, return container, with projectile, to Depot for replacement.

- (g) Reinstall plug on inside of humidity indicator using a 1/2-inch socket head screw key. Turn key clockwise until handtight.
- (h) Reinstall humidity indicator into threaded hole in the container, using ratchet handle with 3/4-inch square male drive and 1-3/8 inch socket or slip-joint pliers. Tighten by turning clockwise until handtight.
- (i) After a 120-hour period, observe humidity indicator card. If the 40 percent humidity sector is not blue, open container, change card and desiccant again, then close container. If after a second 120-hour period the sector is not blue, take the projectile out, put the projectile in a different container, and remark the container. Tools used in replacement of humidity indicator card are key, socket head screw, (1/2-inch) NSN 5120-00-198-5407, and socket, socket wrench 1-3/8-inch, 3/4-inch square male drive, NSN 5120-00-189-7930 and handle, socket wrench, reversible ratchet, 3/4-inch square drive, NSN 5120-00-198-5407 or slip-joint pliers NSN 5120-00-278-0352.

e. Pallets for Projectiles.

(1) Wood Pallets.

- (a) Replace missing nails, and remove and replace bent nails. Firmly hammer in any loose nails.

WARNING

Pallets marked with letter "P" have been treated with pentachlorophenol (penta) and must not be burned.

- (b) Broken pallets or pallets with defective board will be sent to the Defense Reutilization Marketing Office.

(2) Field Artillery Projectile Pallet (FAPP) Metal.

- (a) Check that all parts of assembly (Dwg 12926862) are present.
- (b) Check pallet for CARC top paint coverage. If any area is bare (no green CARC paint), apply CARC polyurethane coating per MIL-C-53039 over bare area, using paint brush. Let paint dry for 30 minutes until dry to touch.

4-10 PROPELLING CHARGES.

- a. General. The only repair authorized for propelling charges at DS and GS levels is retieing charges for separate loading projectiles should they come loose due to handling, etc. See appropriate procedure for retieing individual separate loading charge below.
- b. 8-inch and 155mm Charges (DS and GS levels).

NOTE

See paragraph 4-9b(3) for special procedure for propelling charges M86 and M86A1 for 175mm projectiles.

- (1) Visually inspect propellant containers for dents, punctures, etc.

- (2) Open all containers showing evidence of punctures, severe dents or other penetrating damage or which contain charges known to need retieing.

- (3) Remove propelling charge bags.

- (4) Inspect propelling charge bags for defects listed in table 3-1. To inspect for bag deterioration, proceed as follows:

- (a) Visually inspect bag surface for deterioration of silk celcon cloth. Deterioration will usually be accompanied by discoloration (indicated below) with loss of tensile strength in cloth.

1 Brown spots on white silk bags.

2 Orange spots on green silk bags.

3 Blue spots in white cotton or rayon blend bags. However, discolorations do not always indicate deterioration of cloth. Yellow discoloration of charge bags is not a defect as all M188A1 charges containing stabilizer 2NDPA will discolor. The amount of stabilizer leeching to discolor the cloth is not an indication of stabilizer unserviceability, as the amount needed to discolor is insignificant with respect to loss of stabilizer content.

- (b) Check suspect areas by poking them with index finger. Cloth on badly deteriorated bags should tear or disintegrate with little or no effort.

- (c) If bag proves to be defective, dispose of bag and propellant as directed by local commander.

- (d) If cloth withstands these tests, it is acceptable.

- (5) If charge has separated into increments, it may be retied as follows:

- (a) Assemble increments in correct numerical order with flash reducer at forward end.

- (b) Tie straps tightly using two overlapping square knots on top of the charge.

(6) Obtain a good identical type container and repack acceptable propellant in the original manner.

- (7) Make sure markings are correct on new container.

c. 175mm Charges (DS and GS Levels).

(1) Expendable supplies. Acrylic or silk lacing cord may be required,

(2) Procedure, If charge has separated into increments, it may be retied as follows:

- (a) Assemble bell ends of igniter tubes from increments No. 1 and 3 fully over ends of igniter tube of increment No. 2 with no separation between increment loading assemblies.
- (b) Secure tying straps tightly around top of increment No. 3 using two overlapping square knots.
- (c) Tie lacing cord around assembled charge at junction of increments No. 2 and No. 3.
- (d) After assembly, igniter tube should not protrude beyond end of increment No. 3.

(3) Inspect propelling charges M86 and M86A1. This inspection procedure is only for the propelling charges M86 and M86A1, and does not apply for the M86A2.

- (a) Carefully inspect visually charge containers for dents, punctures, etc.
- (b) Open all containers showing evidence of punctures, severe dents or other penetrating damage,
- (c) Move tie strap to one side, and inspect igniter core assembly in increment No. 3 for evidence of loose black powder granules and collapsed, broken or missing tube.
- (d) Remove propelling charge from container. Remove igniter protector cap and inspect igniter pad, core, and

tube in increment No. 1 for evidence of loose black powder granules, improperly positioned components, missing components, collapsed igniter tube, loose pieces of igniter tube, or protruding igniter core. (This inspection shall be done visually and manually.)

- (e) Examine igniter protector cap for evidence of loose black powder granules. Examine charge for other defects listed in table 3-2.
- (f) Obtain or fabricate a nonsparking rod (wood, brass, etc.) at least 50 inches long of 1/4 inch or less diameter. Round one end of rod with sandpaper or grinder.

CAUTION

WHEN INSERTING ROD INTO IGNITER TUBE DO NOT TRY TO FORCE ROD. EXERCISE CARE IN PREVENTING DAMAGE TO IGNITER PAD.

- (g) Insert rounded end of rod into igniter tube in increment No. 3.
- (h) Depressing along inner wall, push rod slowly and carefully through all three igniter tubes until it comes in contact with igniter pad. Be careful not to puncture pad,
- (i) If resistance is encountered prior to contact with the igniter pad, replace charge in container and return to depot,
- (j) If rod reaches igniter pad, carefully remove rod and consider charge acceptable from this standpoint.
- (k) Obtain a good identical type container and repack acceptable propellant in the original manner.
- (l) Reseal container and make sure markings are correct on new container.

Section IV. REPLACEMENT OF ARTILLERY AMMUNITION COMPONENTS

4-11. General

Replacement ammunition will be installed following procedures in TM 9-1300-251-20. Serviceable ammunition components will be reinstalled and unserviceable components will be replaced by new ones in accordance with procedures given below.

4-12. Nose Fuzes, Closing Plugs, and Eyebolt Lifting Plugs

a. General. Nose fuzes, closing plugs, and eyebolt lifting plugs which require replacement will be removed and new ones installed using procedures in TM 9-1300-251-20, or in d. The M549/M549A1 Protective Lifting Plug is not interchangeable with any other lifting plug.

NOTE

Eyebolt lifting plugs and closing plugs may be obtained by cannibalization.

b. Tools and Equipment

- (1) Pipe vise.
- (2) Brush, nonsparking stainless steel (small).
- (3) File, fine.
- (4) Adapter, fuze to torque wrench.
- (5) Adapter, lifting ring to torque wrench (locally fabricated).
- (6) Torque wrench, 1/2-inch drive (600 inch-pounds).
- (7) Can, disposable flammable waste.
- (8) Safety can, plunger type.
- (9) Fuze wrench.

c. Expendable Supplies.

- (1) Sheet rubber.
- (2) Acetone.
- (3) Pettman cement.

- (4) Grease.

d. Procedures.

- (1) If working on fixed rounds, position an improvised support near pipe vise to cradle cartridge case base.
- (2) Place projectile (protected by sheet-rubber padding) in pipe vise. Close vise jaws slowly until projectile is held firmly.

CAUTION

DO NOT DISTORT PROJECTILE DIAMETER BY OVER-TIGHTENING VISE.

- (3) Place fuze wrench over fuze and engage wrench flats in fuze slots or insert straight bar through eyebolt lifting plug.
- (4) Turn wrench/bar counterclockwise to loosen fuze or plug.
- (5) Remove wrench/bar, unscrew fuze or plug by hand, and remove.
- (6) Package or destroy unserviceable fuze as directed by local commander.
- (7) Inspect fuze well as required (see para 3-1 through 3-8), and clean with dry rag if necessary. Use acetone dampened rag for removal of any explosive contamination.
- (8) Clean threads with nonsparking small stainless steel brush if necessary.
- (9) Use a fine file to remove any edges around previously staked areas or nose of projectile.
- (10) Apply Pettman cement to new fuze threads or lubricate plug threads with grease.

NOTE

Before replacing lifting plug, check for presence and condition of lifting plug gasket. If necessary replace it.

- (11) Carefully thread new fuze or plug clockwise into projectile fuze well. Screw down by hand as far as possible.
- (12) Place appropriate torque wrench adapter over fuze or eyebolt of lifting plug.
- (13) Insert torque wrench drive shaft into adapter and tighten by applying torquing in a clockwise direction to the following specifications:
 - (a) Torque fuzes to 150 to 300 inch-pounds.
 - (b) Lifting plug torque values for different projectiles vary, therefore, adherence to projectile assembly drawing requirements is recommended.

NOTE

Hand tighten aluminum closing plugs. Do not torque them down.

- (14) Remove torque wrench.
- (15) Loosen vise jaws.
- (16) Remove projectile.

4-13 PROPELLING CHARGES.

- a. General. Propelling charges may be installed in semifixed rounds only, using pre-assembled bagged charges such as 105mm howitzer ammunition as follows:
 - (1) Using padding on fiber container end cap to protect primer, place cartridge base down on bench.
 - (2) Remove filler cup from mouth of cartridge case.
 - (3) Remove charge beginning with increment (bag) No. 7 and pull each increment out in order. Assure that all propellant grains are removed.
 - (4) Package or destroy old propelling charge as directed by local commander.
 - (5) Inspect cartridge case as required (see para 3-1 through 3-8).
 - (6) Select appropriate suffix as directed in TM 9-1300-250.
 - (7) Mark lot number with appropriate suffix on cartridge case, projectile, and packaging using stencil or rubber type kit (para 4-19).

- (8) Place replacement propelling charge on bench.
- (9) Without cutting string, place each bag in sequence (beginning with increment No. 1) in cartridge case, shaping bag to fit around primer flash tube. Foil side of bag, increment No. 5, must face towards primer.
- (10) Replace filler cup in mouth of cartridge case.
- (11) Reassemble other components of complete round.

4-14 SUPPLEMENTARY CHARGES.

NOTE

Some M795 projectiles contain a supplementary charge with aluminum tape attached to the top. During maintenance and renovation operations, properly dispose of charge and do not reissue; the supplementary charge lot is No. DAZ97G001-002.

- a. Tools and Equipment.
 - (1) Brush, stainless steel (small).
 - (2) Stencil kit; rubber type set.
- b. Expendable Supplies. Dry rags, stencil ink or paint.
- c. Procedures.
 - (1) Remove fuze or plug and spacer (para 4-12d).
 - (2) Grasp loop and pull out supplementary charge.
 - (3) Dispose of as directed by local commander.
 - (4) Inspect fuze well as required (see para 3-1 through 3-8) and clean with dry rags, as necessary.
 - (5) Clean threads with nonsparking stainless steel brush if necessary.
 - (6) Insert new supplementary charge in fuze well, felt pad first.
 - (7) Reinstall spacer tube.
 - (8) Reinstall fuze or plug (para 4-12d).
 - (9) Select appropriate suffix as directed in TM 9-1300-250.

- (1) Add appropriate suffix to lot number on projectile, cartridge case, and packaging (para 4-19).

NOTE

At present it is expected that DS personnel will not have facilities available for complete repainting of artillery projectiles and will generally be limited to a touch-up operation. For this reason the ring gages necessary to check the complete repaint have only been authorized for GS at present.

4-15 BURSTERS (GS LEVEL ONLY).

- a. General. Bursters will normally be replaced at GS level only on direction from higher authority.
- b. Tools and Equipment.
 - (1) Drum, 55-gallon.
 - (2) Flashlight.
 - (3) Adapter, fuze to torque wrench.
 - (4) Adapter, lifting ring to torque wrench (locally fabricated).
 - (5) Torque wrench, 1/2-inch drive (600 inch-pounds).
 - (6) Can, disposable, flammable waste.
 - (7) Safety can, plunger type.
 - (8) Pipe vise.
- c. Expendable Supplies.
 - (1) Wooden dowel.
 - (2) Acetone.
 - (3) Sheet rubber padding.
 - (4) Pettman cement.
 - (5) Procedures.



If at any time during replacement of bursters, smoke or heat is observed escaping from the fuze well, immediately immerse projectile in a drum of water. Destroy projectile in accordance with local regulations.

- (1) Position a 55-gallon drum almost full of water next to work area.
- (2) If working on fixed rounds, position wooden block(s) under base of cartridge case for support.
- (3) Place projectile (protected by sheet rubber padding) in pipe vise. Close vise jaws slowly until projectile is held.



Do not distort projectile diameter by overtightening vise.

- (4) Attach appropriate torque wrench adapter to torque wrench and position adapter over fuze or lifting plug.
- (5) Turn torque wrench counterclockwise to loosen fuze or plug while watching indicator.



Do not apply more than 300 inch-pounds or less, set aside for later dispositions as follows:

- (a) If five or less such rejects are accumulated from a lot, destroy them as directed by local commander.
 - (b) If six or more of these rejects are accumulated, request disposition instructions through ammunition maintenance channels.
- (6) Once fuze or plug is loosened and can be finger-turned, loosen pipe vise and carefully remove projectile.

- (7) Hand twist fuze or plug out of projectile. Set fuze aside in a secure and safe position.
- (8) On 105mm projectiles use fingers to twist out small metal cup at base of fuze well.
- (9) Keeping hand in fuze well, tilt projectile nose downward until burster slides out of casing at base of fuze well.
- (10) Grasp burster and remove it completely.
- (11) Repack for disposal as required by the SOP.
- (12) Hold projectile nose downward and shake to remove any loose dirt or explosive chips in burster casing.
- (13) Use explosion proof flashlight to inspect burster casing.
- (14) Use a wooden dowel or stick and an acetone dampened rag to remove any explosive contamination found.
- (15) Inspect new burster as required (see para 3-1 through 3-8).
- (16) Insert acceptable burster, with felt pad end first or in orientation indicated on burster, in burster casing.
- (17) Apply Pettman cement to lower four projectile nose threads of 105mm projectiles only.
- (18) Screw metal cup into base of fuze well on 105mm projectiles.
- (19) Screw on original nose fuze or lifting plug as far as it will go by hand.
- (20) Secure projectile in rubber padded jaws of pipe vise according to (3) above.
- (21) Using torque wrench and appropriate adapter, tighten fuze or lifting plug to the following specifications:
 - (a) Torque fuzes to 150 to 300 inch-pounds.
 - (b) Torque lifting plugs to 100-200 inch-pounds.
- (22) Select appropriate suffix as directed in TM 9-1300-250.
- (23) Add appropriate suffix to projectile lot number wherever it appears (para 4-19).
- (24) If tetrytol bursters of 105mm projectiles M60 are replaced with composition B bursters, add appropriate suffix to M60 designation wherever it appears.
 - (a) Use F1 suffix with burster XM53.
 - (b) Use A1 suffix with bursters M53A1

Section V. TOUCHUP, PAINTING, AND MARKING

4-16. Touchup

a. General. For general touchup operations use following procedures. However, see b below for special procedure for cartridge cases. See paragraph 4-16c for touchup of Copperhead projectiles and metal containers.

(1) Tools and equipment.

- (a) Brush, paint.
- (b) Spray gun.
- (c) Small brush.
- (d) Stencil kit; rubber type set.
- (e) Can, disposable flammable

waste.

(f) Safety can, plunger type.

(g) Respirator.

(2) Expendable supplies.

- (a) Masking tape.
- (b) Abrasive paper.
- (c) Primer, zinc chromate.
- (d) Paint, ammunition.
- (e) Ink, marking stencil.
- (f) Alcohol, denatured.

(3) Procedure.

- (a) Clean item according to section II.
- (h) Buff cleaned bare metal area(s) and surrounding paint lightly with fine sandpaper.
- (c) Cover rotating band, legible markings, and threaded surfaces with masking tape.
- (d) Wipe off surface of projectile with clean rag dampened with alcohol to remove all loosened paint particles.

WARNING

WEAR RESPIRATOR DURING SPRAY PAINT OPERATIONS.

- (e) Using spray gun, spray can or brush, cover bare metal with thin coat of zinc chromate primer and allow to dry.
 - (f) Using spray can, spray gun, or brush, paint primed area with two thin coats of proper color paint according to TM 9-1300-251-20. Allow first coat to dry thoroughly before applying second.
 - (g) After paint has dried, remove masking tape.
 - (h) Touchup markings using small paint brush or re-stencil, as required (para 4-19).
- b. Cartridge Cases.

WARNING

REMOVE PROPELLANT CHARGE FROM CARTRIDGE CASE AND PLACE IN COLLECTION CONTAINER PRIOR TO BEGINNING PROCEDURES OUTLINED BELOW.

- (1) Tools and equipment.
 - (a) Scissors.

- (b) Small brush.
- (c) Can, disposable flammable waste.

- (d) Safety can, plunger type.
- (2) Expendable supplies.

- (a) Masking tape.
- (b) Steel wool.
- (c) Varnish, ammunition.

(3) Procedure.

(a) Protect primer from accidental impact by cutting out a piece of cardboard slightly larger than primer's exposed surface and securing it over primer with masking tape.

(b) Use steel wool to remove rust spots and smooth out scratches in varnish surface.

(c) Feather edges of cleaned areas with adjacent surfaces.

(d) Touchup all cleaned areas with ammunition varnish using a clean small brush.

(e) Allow surface to dry until surface is no longer tacky.

(f) Inspect and touchup or replace markings (para 4-19).

(g) Inspect and reinstall propellant charge in accordance with paragraph 4-13.

(h) Remove masking tape and primer protector.

c. M712 and M823 Projectiles and Metal Containers. Refer to TM 9-1300-251-20 for touchup procedures.

4-17. Touchup of 120MM Combustible Cartridge Case

a. General. The procedure outlined in this section shall be utilized at Depot, Direct Support, and General Support Maintenance Levels.

b. Touchup Criteria. Cartridge cases which have yellowish-white combustible material showing, less than 10 percent (30 in²/194 cm²) of the total surface area of the cartridge case, will be touched up. Cartridge cases with cracks which do not completely penetrate the cartridge case material will also be touched up. Cartridge cases with other forms of damage (but deemed

serviceable, per paragraph 3-9, a.1. of TM 9-1300-251-20&P will not be touched up, but given priority of issue and use. Damaged cartridge cases, which are deemed unserviceable, will be turned-in as unserviceable.

c. Preparation of Cartridge Case.

- (1) Remove cartridge to be touched up from shipping container.
- (2) Protect primer by taping (masking tape) cardboard backing disc over it. Tape base of cartridge case, but do not apply any tape directly to primer.

WARNING

Do not directly apply any form of tape to surface of combustible cartridge case. If tape is applied to combustible case, removal of tape may cause peeling off of polyurethane finish.

Do not use any form of cleaning solvent or water to clean the combustible cartridge case.

- (3) Cover metal base obturator and projectile obturator/rotating band with two inch wide masking tape.

WARNING

Electrically ground cartridge before cleaning. secure ground clip to metal lip of cartridge case base.

- (4) Remove dirt, mud, and any other foreign material from the cartridge by using dry rags (preferably cotton rags). Exercise care when cleaning case as not to further damage/degrade polyurethane finish.
- (5) Using nonsparking knife, gently scrape off loose polyurethane/aluminum oxide paint from the cartridge case. Care must be taken when scraping to prevent unnecessary removal of paint.

WARNING

Do not buff area with yellowish-white combustible material showing. Combustible material is friction sensitive and can auto-ignite causing a serious fire hazard.

NOTE

Personnel directly involved with buffing operations will wear disposable dust mask.

Buffing operation will be conducted in well ventilated work areas.

No power tools will be used to perform buffing operation. Buffing operation will be done manually.

- (6) Buff area adjacent to bare (yellowish-white) combustible material of cartridge case to be touched up with 320 grit abrasive paper. Buffing shall consist of short-slow strokes with minimum amount of force applied to the abrasive paper.
- (7) Clean buffed area with a dry clean rag (cotton) and using an OSHA-approved compressed air blow off gun, blow off remaining debris.

d. Paint Application.

WARNING

Use of any paint other than that prescribed below is not authorized. Use of unauthorized paints may destroy or degrade the combustible cartridge case material.

- (1) Obtain and prepare paint (Rust-Oleum Bright Coat Metallic Finish Aluminum 7715, NSN: 8010-01-347-8920) as per directions on spray can.

NOTE

Three individual thin layers of paint must be applied in order to obtain the desired protection of the combustible cartridge case.

Personnel involved with paint spraying application will wear an NIOSH approved dust and vapor respirator.

- (2) Position spray can nozzle approximately eight inches from surface of cartridge case area to be painted. Apply paint with slow and even strokes. Spray over the polyurethane finish, extend perimeter of paint application into the polyurethane finish by approximately one inch. Paint must evenly and completely cover effected area.

NOTE

Do not permit paint to run or drip. Use clean, dry rags to remove runs or drips.

- (3) Visually inspect touched up area for workmanship.
- d. To facilitate adequate protection of the combustible cartridge case, three thin layers of paint must be applied to the case area being touched up. For best results, ensure the prior layer of paint is dry to the touch before application of the next paint coating.
- (1) Upon completion of the third layer, allow paint to dry before repacking.



Exercise care when removing tape from cartridge case not to crack or chip new paint.

- (2) Prior to repacking, remove tape from projectile and base obturator. Remove cardboard packing disc from base of cartridge.
- e. Equipment and Material Requirements.
 - (1) Equipment Requirements:
 - (a) Compressor, air, OSHA approved.
 - (b) Knife, nonsparking, NSN: 5110-00-344-9900.

- (c) Air respirator, dust and vapor, NIOSH approved.

(2) Material Requirements:

- (a) Mask, dust, locally procured.
- (b) Spray paint, Rust-Oleum Bright Coat Metallic Finish Aluminum 7715, NSN: 8010-01-347-8920.
- (c) Paper, abrasive, 320 grit, NSN: 5350-00-224-7203.
- (d) Tape, masking, two-inch wide, NSN: 7510-00-266-6710.
- (e) Tape, masking, one-inch wide, NSN 7510-00-266-6712.

4-18 PAINTING.

a. General.

- (1) Ammunition and ammunition components which have been cleaned extensively, or to a degree that large areas of metal surface are bare, will be repainted in accordance with procedures below.
- (2) Temperature of both paint and ammunition must be between +50°F and +100°F for paint to adhere and dry properly. Also, surrounding temperature must be above + 50°F.
- (3) M712 and M823 projectiles and metal containers will have large areas painted in accordance with procedures in paragraph 4-16c for touchup.
- (4) M795 projectile will be painted with CARC paint only (Dwg 12977242).

b. Separate Loaded Projectiles.

(1) Tools and equipment.

- (a) Ring gage.
- (b) Wire brushes.
- (c) Adapter, fuze to torque wrench.
- (d) Adapter, lifting ring to torque wrench (locally fabricated).

- (e) Torque wrench, 1/2-inch drive (600 inch-pounds).
 - (f) Respirator.
 - (g) Paint sprayer.
 - (h) Can, disposable flammable waste.
 - (i) Safety can, plunger type.
- (2) Expendable supplies.
- (a) Rag.
 - (b) Alcohol.
 - (c) Primer, zinc chromate.
 - (d) Paint, enamel, ammunition.
 - (e) Paint, CARC (Dwg 12977242).
- (3) Procedure (See (4) below for alternate procedure).
- (a) Clean projectiles thoroughly (section II).
 - (b) Sort out projectiles that do not require repainting and those with major damage to rotating band or otherwise unserviceable. Dispose of unserviceable projectiles per SOP.
 - (c) Remove as much of the paint as possible with cleaning materials furnished. Completely strip paint off bourrelet.
 - (d) Wipe off surface of projectile with clean rag dampened with alcohol to remove all loosened paint particles.
 - (e) After cleaning, check diameter of projectile with ring gage. Projectiles which do not pass ring-gage test by reasons other than painted surfaces, will be classified as unserviceable and reported on DA Form 2415 in accordance with TM 38-750.
 - (f) If missing or not tightened down, use a torque wrench and adapter socket to install lifting plug (with gasket) in fuze well with an assembly torque of 100 to 200 inch-pounds.

- (g) If possible, obtain a rack or fixture approved for supporting the total weight of several projectiles suspended from it by their lifting plugs.

NOTE

If no approved fixture is available use alternate procedure contained in (4) below.

- (h) Suspend projectiles by lifting rings high enough off ground to give complete access for painting.
- (i) Cover rotating band completely with masking tape.

WARNING

Wear respirator during spray paint operations.

- (j) For the M795 projectile prepare the bare metal area in accordance with Finish No. 5.1.1 (Zinc phosphate, TT-0-490, Type 1) of MIL-STD-171.
- (k) For all other 155mm projectiles, spot prime any bare metal with a thin coat of zinc chromate primer. Do not prime over good paint but apply over the feathered edge of the spot. Assure that all bare metal is primed.
- (l) Air-dry 30 to 60 minutes, or until surface is no longer tacky.

NOTE

A longer drying time may be required at lower temperatures and/or high humidity.

- (m) Spray paint projectile with a thin coat of appropriate body color according to TM 9-1300-251-20&P. Assure that coverage is complete. For M795 projectile use CARC paint drawing No. 12977242.
- (n) Air-dry until surface is no longer tacky.
- (o) Inspect to assure that paint covers projectile completely, including old unwanted markings.
- (p) Remove masking tape.

- (p) Remove projectile from suspension fixture and painting area. Set it, base down, on a clean piece of cardboard or a couple layers of newspaper to thoroughly dry (overnight or longer).
 - (q) Check bourrelet diameter with appropriate ring-gage as detailed in para 3-1 through 3-8. If projectile fails ring gage test, strip off paint and repaint.
 - (r) Remark/re-stencil as required.
- (4) Alternate procedure.
- (a) Prepare projectiles for painting as instructed in steps (a) through (f) in (3) above.
 - (b) Place projectiles, base down, on floor.
 - (c) Paint and then air-dry entire exposed surface as detailed in steps (i) through (o) in (3) above.
 - (d) When dry, carefully lay projectiles on their sides, supported by boards or other suitable material.
 - (e) Paint and then air-dry entire base area as detailed in steps (i) through (o) in (3) above.
 - (f) After projectile is thoroughly dry, remove masking tape and check bourrelet diameter with appropriate ring gage as detailed in paragraphs 3-1 through 3-8. If projectile fails ring-gage test, strip off paint and re-paint.
 - (g) Remark/re-stencil as required.

c. Semifixed Projectiles. Remove semifixed projectiles from cartridge cases and paint projectiles as instructed in b above. Complete repaint of cartridge cases for semifixed projectiles is not authorized. See paragraph 4-16b for special touchup procedure of cartridge cases.

d. Fixed Rounds.

(1) Tools and equipment.

- (a) Scissors.

- (b) Ring gage.
- (c) Respirator.
- (d) Paint sprayer.
- (e) Can, disposable flammable waste.
- (f) Safety can, plunger type.
- (g) Paint rack (locally fabricated).

(2) Expendable supplies.

- (a) Rags.
- (b) Masking tape (2 inches).
- (c) Kraft paper.
- (d) Primer, zinc chromate.
- (e) Paint, ammunition.

(3) Procedure.

- (a) Clean rounds thoroughly (section II).
- (b) Sort out only rounds requiring repainting.
- (c) Protect primer from accidental impact by using the end cap and primer protection pad of the fiber containers in which the round is stored and shipped.
- (d) Remove as much of the paint as possible with materials furnished. Completely strip paint off bourrelet.
- (e) Wipe off surface of component with clean rag dampened with alcohol to remove all loosened paint particles.
- (f) After cleaning, check diameter of projectile with ring gage. Destroy rounds which do not pass ring-gage test in accordance with local regulations.
- (g) Place round in rack (para 2-1 through 2-3) so that component (either projectile or cartridge case) to be painted extends beyond and does not contact rack.

- (h) When painting one component (projectile or cartridge case), cover other component using masking tape and kraft paper.
- (i) Protect primer from accidental impact by using the end cap and primer protection pad of the fiber containers in which the round is stored and shipped.
- (j) Cover rotating band completely with masking tape.

WARNING

WEAR RESPIRATOR DURING SPRAY PAINT OPERATIONS.

- (k) Spot prime any bare metal on component with a thin, sprayed coat of zinc chromate primer. Do not prime over good paint, but do not worry about over spray from spot priming. Assure that all bare metal is primed.
- (l) Air-dry 30 to 60 minutes, or until surface is no longer tacky.

NOTE

A longer drying time may be required at lower temperatures and/or high humidity.

- (m) Spray paint component with a thin coat of appropriate body color, according to TM 9-1300-251-20, Assure that coverage is complete.
- (n) When thoroughly dry, remove masking tape and kraft paper. Check bourrelet diameter with appropriate ring gage.

e. Hardware (Metal Grommets, Lifting Plugs, etc.).

(1) Tools and equipment.

- (a) Respirator.

- (b) Paint sprayer.
- (c) Can, disposable flammable waste.

- (d) Safety can, plunger type.

(2) Expendable supplies.

- (a) Masking tape,
- (b) Primer zinc chromate.
- (c) Paint, ammunition.

(3) Procedure.

- (a) Clean item in accordance with instructions in section II.
- (b) Cover threads and other areas which do not require painting with masking tape.
- (c) Suspend item from wire hook.

WARNING

WEAR RESPIRATOR DURING SPRAY PAINT OPERATIONS.

- (d) Spray bare metal with a thin coat of zinc chromate primer.
- (e) Air-dry until surface is no longer tacky.
- (f) Inspect item to assure that there are no bare areas. Re-prime bare areas, as required.
- (g) Spray item with a thin coat of paint in the appropriate color, according to TM 9-1300-251-20.
- (h) Air-dry until surface is no longer tacky.
- (i) Inspect to assure complete paint coverage. Re-paint spots as necessary.
- (j) Remove masking tape.

f. Wood Packing Box. The normal reason for painting wooden boxes will be obliteration of old markings.

- (1) Tools and equipment.
- (a) Paint sprayer.
 - (b) Can, disposable flammable waste.
 - (c) Safety can, plunger type.
- (2) Expendable supplies.
- (a) Masking tape.
 - (b) Paint, ammunition.
 - (c) Lacquer, obliterating.
- (3) Procedure.
- (a) Assure that box is clean and dry.
 - (b) Cover valid markings, if legible, with masking tape.

WARNING

WEAR RESPIRATOR DURING SPRAY PAINT OPERATIONS.

- (c) Spray with olive-drab enamel or marking obliterating lacquer as required to obliterate unwanted markings.
- (d) Air-dry until surface is no longer tacky.
- (e) Inspect to assure complete coverage. Re-paint spots if necessary.
- (f) Remove masking tape.
- (g) Mark as required, in accordance with instructions in paragraph 4-20.

g. Metal Packing Box or Tubular Container.

- (1) Clean containers in accordance with section II.
- (2) Paint containers using the preceding procedures:
 - (a) Small items may be suspended to allow complete coverage (e. above).

- (b) Large items may require two separate sprayings (one for sides and top, and one for base) to completely cover surface (alternate procedure, b. (4) above).

h. Fiber Tube Container.

- (1) Tools and equipment.
- (a) Paint brush.
 - (b) Paint sprayer.
 - (c) Can, disposable flammable waste.
 - (d) Safety can plunger type.
 - (e) Respirator.
- (2) Expendable supplies.
- (a) Rags.
 - (b) Kraft paper.
 - (c) Masking tape.
 - (d) Coating compound, bituminous.
 - (e) Paint (black), ammunition.
 - (f) Primer, zinc chromate.
 - (g) Coating compound.
- (3) Procedure.
- (a) Clean container and cap section II
 - (b) After cleaning, inspect and reject components with penetrating damage or rust which cannot be removed.
 - (c) Cover metal ends and unpainted inner tube with paper and masking tape.

WARNING

WEAR RESPIRATOR DURING SPRAY PAINT OPERATIONS.

- (d) Brush-paint or spray outer surfaces of fiber tube and cap with coating compound.

- (e) Air-dry until surface is no longer tacky.
- (f) Inspect to assure complete coverage. Repaint spots as necessary.
- (g) Remove masking tape and paper from cap and inner tube.
- (h) Cover fiber surfaces with masking tape and paper.

WARNING

WEAR RESPIRATOR DURING SPRAY PAINT OPERATIONS.

- (i) Spray metal ends with zinc chromate primer.
- (j) Air-dry until surface is no longer tacky.
- (k) Spray metal ends with black paint.
- (l) Air-dry until surface is no longer tacky.
- (m) Inspect to assure complete coverage. Repaint as necessary to cover spots.
- (n) Remove masking tape and paper.

4-19. Color Coding of Boxes with Light Loads

a. General. Organizations will apply this procedure when boxes with less than full contents are to be returned to storage area or transported to new location. When painting of boxes is required, re-marking (except quantity) may be avoided by applying masking tape on markings prior to painting box.

b. Tools and equipment.

- (1) Paint brush.
- (2) Paint sprayer.
- (3) Can, disposable flammable waste.
- (4) Safety can, plunger type.
- (5) Stencil kit, rubber type set.

- (6) Respirator.

c. Expendable supplies. Orange paint, and masking tape.

d. Procedure. Boxes with less than full contents will be painted orange as follows:

- (1) Check contents with markings on box to verify that nomenclature and lot number are correct.
- (2) Make diagram of markings on box and record all markings except quantity figure.

WARNING

WEAR RESPIRATOR DURING SPRAY PAINT OPERATIONS.

- (3) With brush or paint sprayer apply orange paint to all outer surfaces of box. If enamel is not available use orange lacquer.
- (4) When box is dry, re-mark box from diagram according to paragraph 4-19.
- (5) Count quantity of items in box and mark number on box in the same position as original quantity figure.
- (6) Stencil words "LIGHT BOX" on each side of box, using approximately same size letters as original markings.

4-20. Marking

a. General.

(1) Assure that all incorrect markings are obliterated.

(2) Clean all marking equipment as often as necessary and at end of each shift or termination of job, whichever comes first.

b. Tools and Equipment.

- (1) Rubber type set.
- (2) Stencil kit.
- (3) Fountain stencil brush.
- (4) Worktable.

- (5) Can, disposable flammable waste.
- (6) Safety can, plunger type.
- c. Expendable Supplies.
 - (1) Rags.
 - (2) Stencil ink.
 - (3) Solvent, acetone or alcohol.
 - (4) Disposable gloves.
 - (5) Masking tape.
 - (6) Stencil board (GS level).

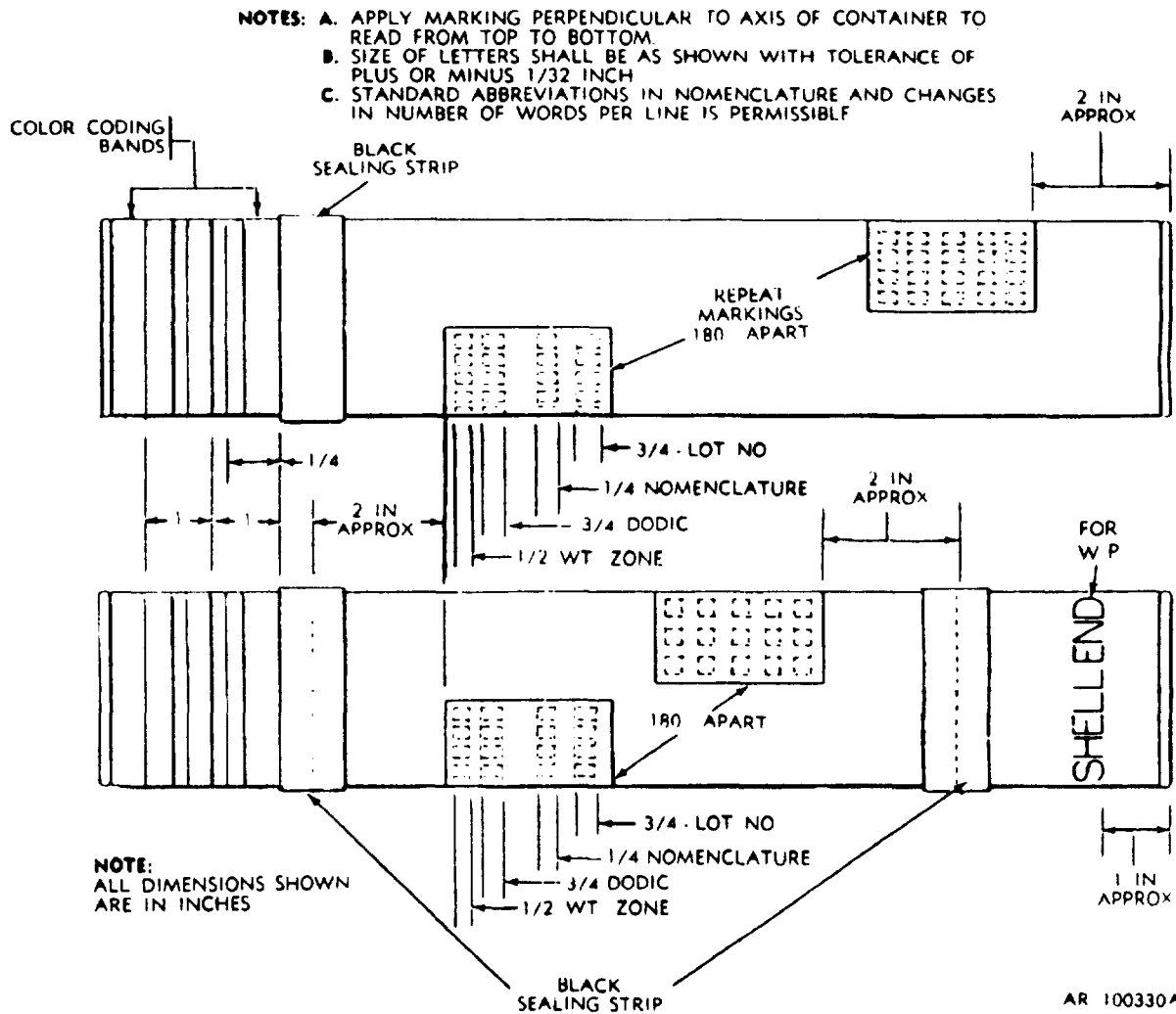
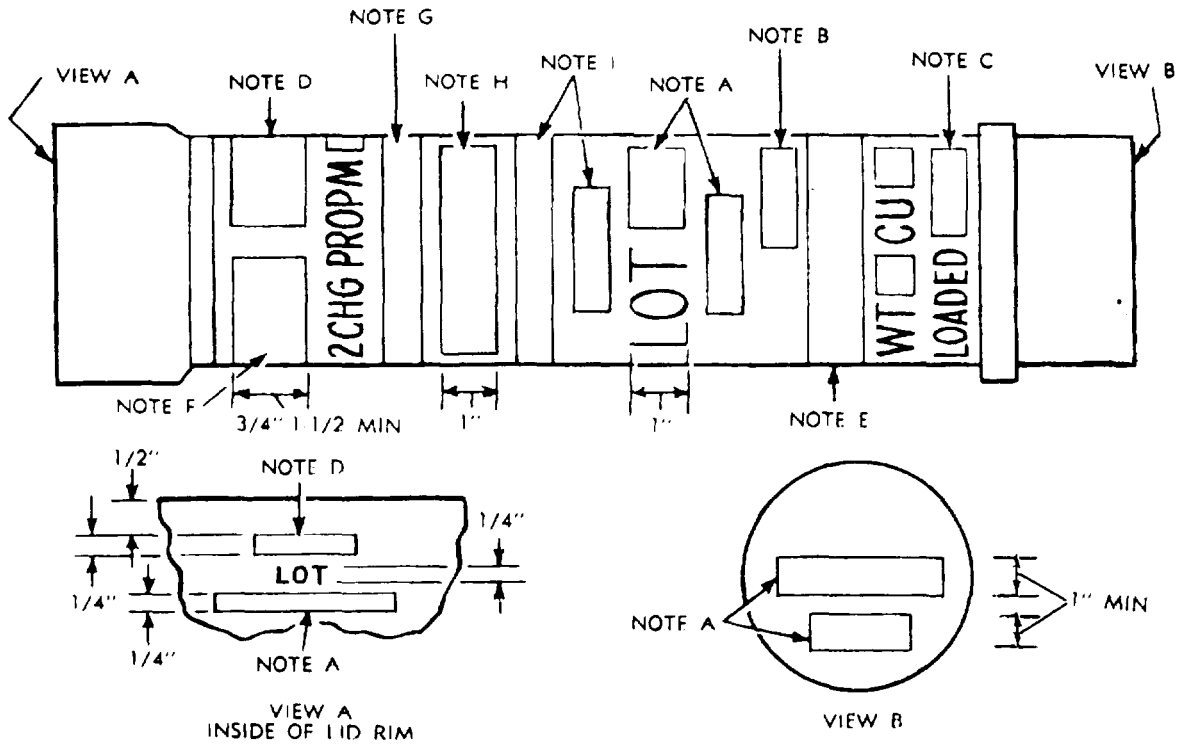

Figure 4-1. Marking on fiber containers.



- NOTES:
- A. INSERT LOT NO INCLUDING YEAR OF MFR (LAST 2 DIGITS)
 - B. INSERT "GREEN BAG" WHEN APPLICABLE
 - C. INSERT MONTH AND YEAR LOADED
 - D. INSERT DODIC
 - E. FOR WHITE BAG CHARGES ONLY, ENCIRCLE CONTAINER WITH 3-INCH WIDE WHITE BAND AND DISREGARD NOTE B.
 - F. INSERT FSN.
 - G. INSERT NUMBER AND DESIGNATION OF PRIMER
 - H. CALIBER AND WEAPON DESIGNATION
 - I. DOT MARKINGS

AR 100021

Figure 4-2. Marking on propelling charge container.

d. Procedure for Packaging Materials.

- (1) Unless otherwise specified, markings will be of a color which contrasts with color of packaging material.
- (2) For specific markings see ammunition data card or copy from old package.
- (3) For location and sizes of markings refer to figures 4-1 through 4-6.
- (4) Re-marking is not required on waxed surfaces; however, inner pack must be marked with information usually found on item. If items have no inner packs, information

must be stenciled on cardboard and included in repacked box.

- (5) Apply markings by either rubber-type or stencil method outlined in f. below.

e. Procedure for Ammunition.

- (1) See TM 9-1300-251-20 for color coding. Generally colors used in repainting or marking will be the same as those colors originally found on the ammunition.
- (2) For specific markings, see ammunition data card or another item from same lot.

- (3) For location and size of markings, refer to appendix E. Note that sizes may not be the same as they were originally because only a limited number of size stencils are available at DS and GS levels.
 - (4) Apply markings by either rubber-type or stencil method outlined in f. below.
- f. Methods.
- (1) Rubber-type method.
 - (a) Set type in holder giving required information.
 - (b) Apply a small amount of ink to ink plate.
 - (c) Roll brayer back and forth on ink plate to distribute ink on brayer.
 - (d) Roll inked brayer lightly across face of rubber type to apply light film of ink to type.

NOTES:

- 1 - INSERT DEPARTMENT OF DEFENSE IDENTIFICATION CODE.
- 2 - INSERT DESCRIPTIVE NOMENCLATURE.
- 3 - INSERT LOT NUMBER.
- 4 - INSERT DATE (MONTH AND YEAR) LOADED.
- 5 - MARK "PACKAGED WITH DESICCANT - DO NOT OPEN UNTIL READY FOR USE OR INSPECTION" ON TOP OF BOX IN ANY CONVENIENT UNOBSTRUCTED LOCATION. SIZE OF LETTERS TO BE APPROX 1/4 INCH HIGH.
- 6 - INSERT "8", "10" OR "12".
- 7 - VT DECAL, WHEN APPLICABLE.

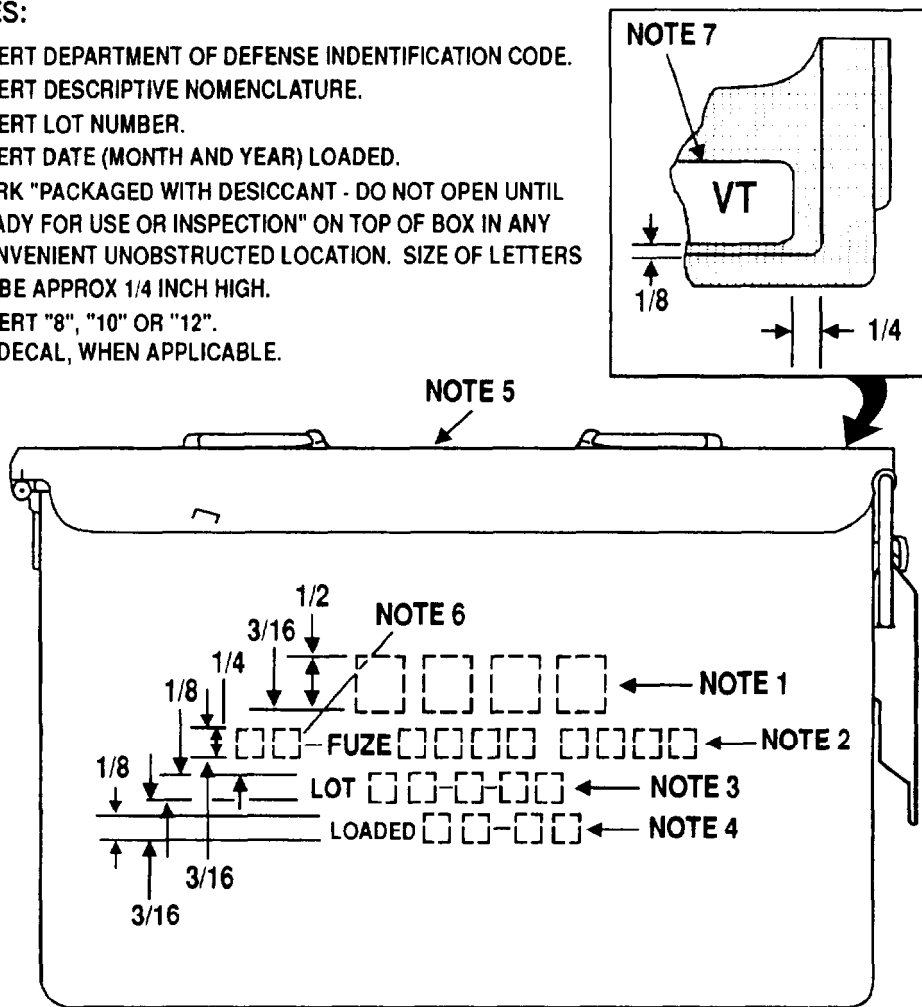

NOTE:

ALL DIMENSIONS SHOWN ARE IN INCHES

U
AR 100331

Figure 4-3. Marking on metal packing box.

- (e) Place item in position to receive marking then roll carefully across face of rubber type to apply ink marking.
- (2) Stencil method.
 - (a) Make a stencil giving required information.
 - (b) Apply small dab of ink to ink plate.
 - (c) Rub brush in ink to apply ink to bristles.
 - (d) Position stencil over location on item to receive marking.
 - (e) While holding stencil firmly against item (using masking tape if required), rub bristles of brush over stencil to apply inked marking to item. (A spray gun or can with paint of proper color may be used as an alternate.)
 - (f) Remove stencil and/or masking tape.
 - (g) Check markings to make sure they are correct, neat, and legible.

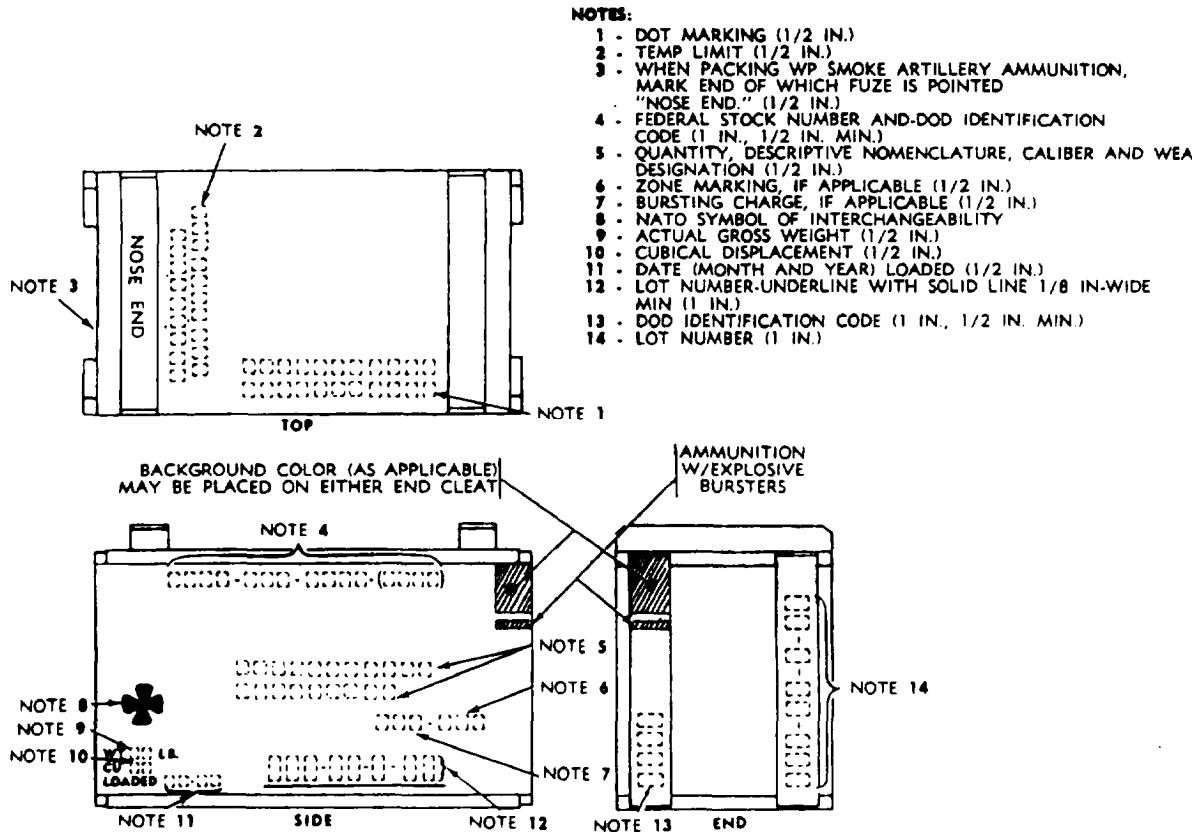

AR 100332A

Figure 4-4. Marking on wooden packing box.

1. INSERT LOT NUMBER.
2. INSERT GROSS WEIGHT POUNDS.
3. INSERT CUBICAL DISPLACEMENT.
4. INSERT DESCRIPTIVE NOMENCLATURE.
5. INSERT PROPER SHIPPING NAME AND IDENTIFICATION NUMBER.
6. INSERT NATIONAL STOCK NUMBER AND DODIC.
7. SPACE RESERVED FOR OVERSEAS ADDRESS.
8. PACK 6 PROJECTILES IN PALLET FOR 8" AND 175MM,
8 PROJECTILES IN PALLET FOR 155MM.

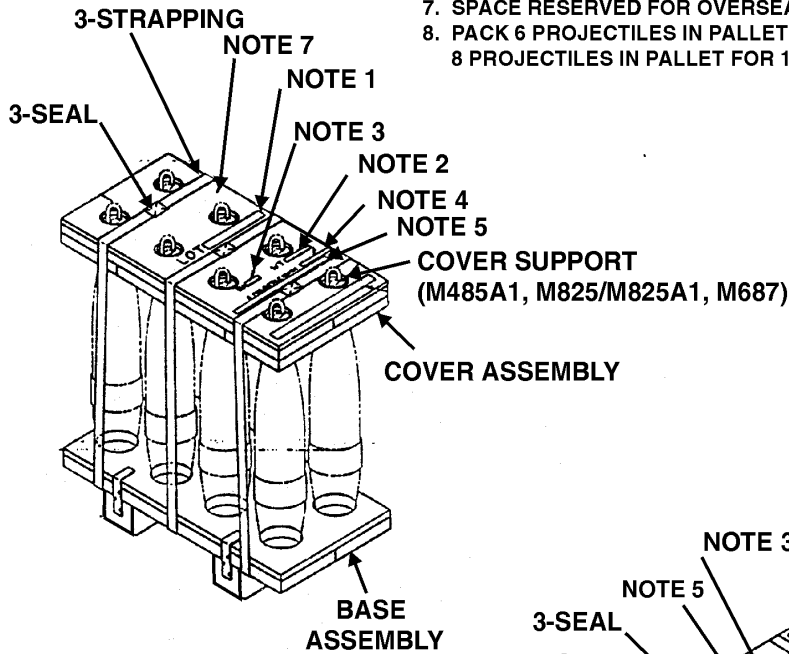

8-PROJECTILE PALLET

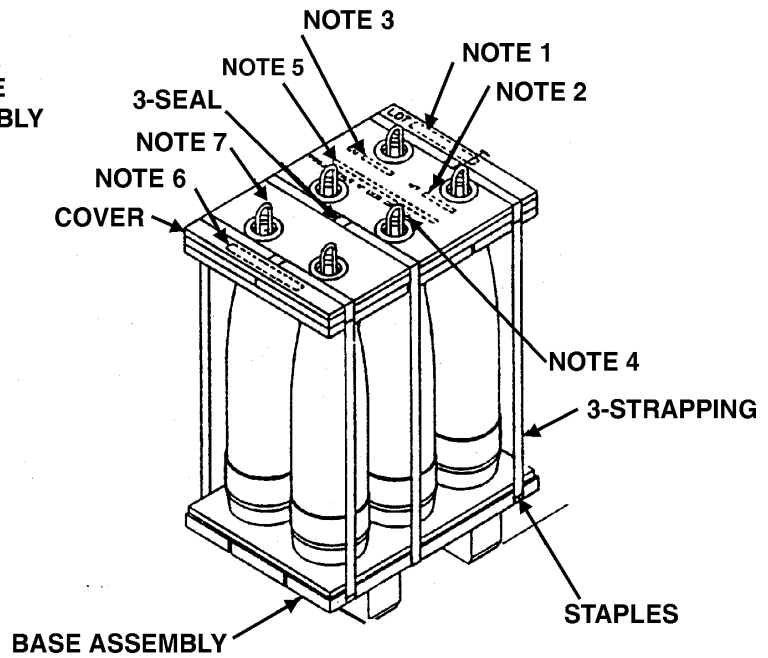

6-PROJECTILE PALLET

AR 8158

Figure 4-4.1. Palletizing (Wood Pallet).

GENERAL NOTES

1. INSERT LOT NUMBER
2. INSERT GROSS WEIGHT POUNDS.
3. INSERT CUBICAL DISPLACEMENT.
4. INSERT DESCRIPTIVE NOMENCLATURE.
5. INSERT PROPER SHIPPING NAME AND IDENTIFICATION NUMBER.
6. INSERT NATIONAL STOCK NUMBER AND DODIC.
7. SPACE RESERVED FOR OVERSEAS ADDRESS.
8. PACK 6 PROJECTILES IN PALLET FOR 8" AND 175MM, 8 PROJECTILES IN PALLET FOR 155MM.

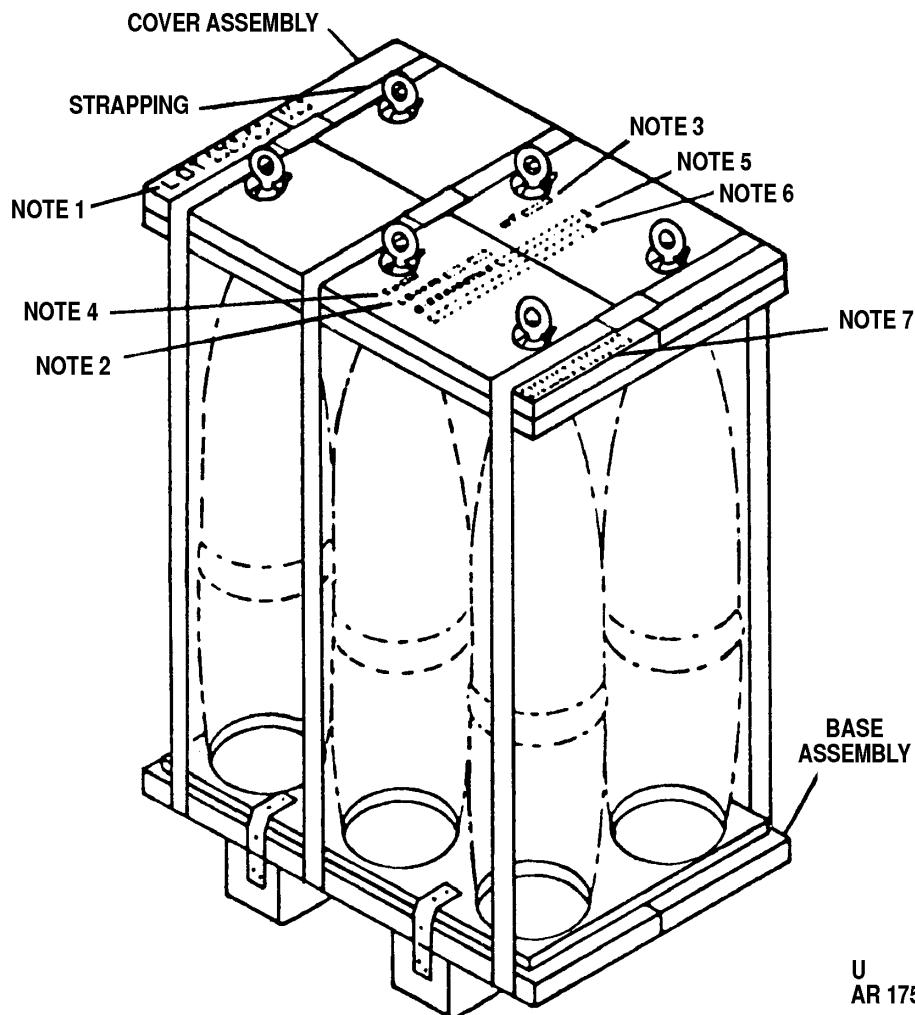

U
AR 1752

Figure 4-5. Palletizing.

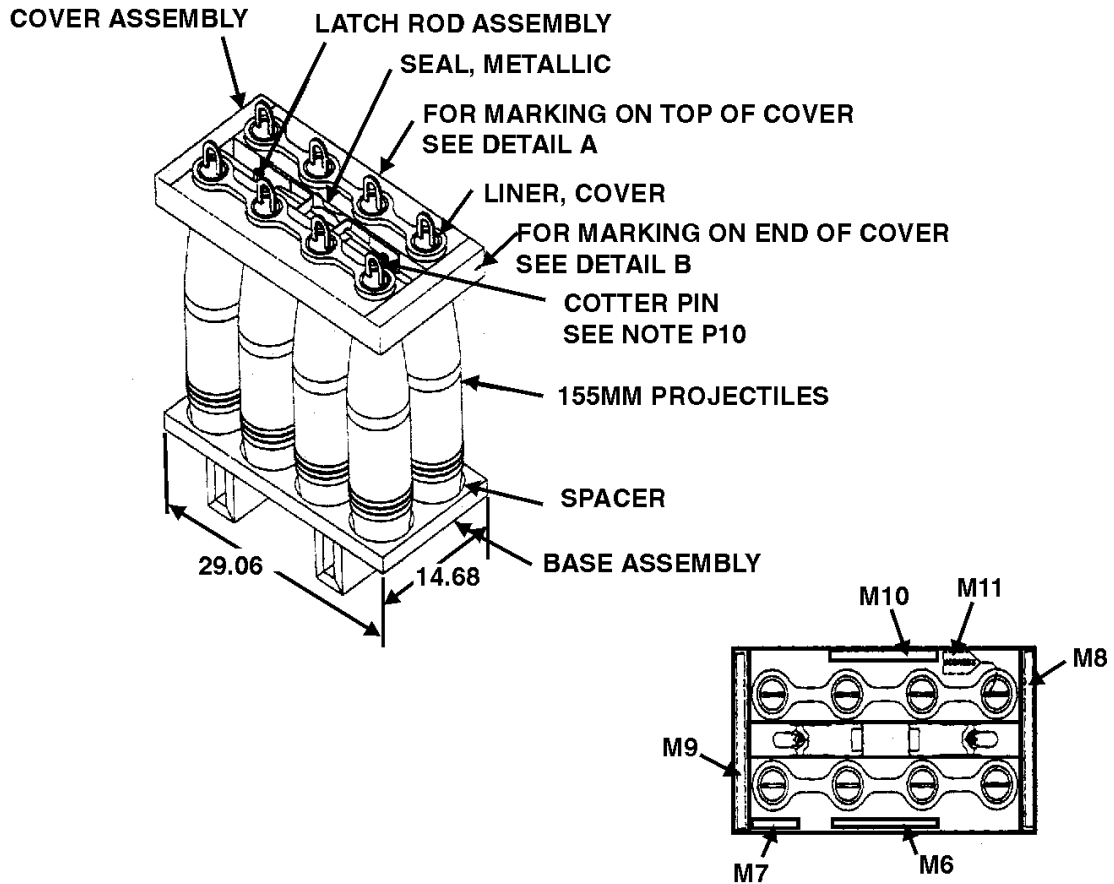

MARKING INSTRUCTIONS

- M1 EXCEPT FOR BAR CODING, SEE M12, MARKING SHALL BE STENCILED OR STAMPED ON TOP.
- M2 LETTERS AND FIGURES SHALL BE MARKED WITH STENCIL INK, SEE NOTE 2 & 3.
- M3 ALL LETTERS AND NUMBERS SHALL BE A MINIMUM OF 1/2 INCH HIGH AND THERE SHALL BE AT LEAST 1/8 INCH SPACING BETWEEN LINES.
- M4 THE RELATIVE POSITIONS OF THE VARIOUS MARKINGS SHALL BE LOCATED AS SHOWN IN DETAIL A, IN ORDER THAT THE MARKINGS ARE NOT COVERED WHEN BUNDLING STRAPS ARE UTILIZED.
- M5 THE MARKING BLOCKS SHOWN ARE FOR ILLUSTRATION PURPOSES ONLY.
- M6 INSERT LOT NUMBER PER MIL-STD-1168 (LOT NUMBER SHALL BE UNDERLINED).
- M7 INSERT GROSS WEIGHT TO THE NEAREST POUND.
- M8 INSERT DESCRIPTIVE NOMENCLATURE, SEE TABLE 1.
- M9 INSERT PROPER SHIPPING NAME AND IDENTIFICATION NUMBER, SEE TABLE 1.
- M10 INSERT NATIONAL STOCK NUMBER AND DODIC, SEE TABLE 1.
- M11 THIS TAG RESERVED FOR OVERSEAS ADDRESS, SEE NOTE 5.
- M12 SEE DWG 12982865 FOR BAR CODE LABEL REQUIREMENTS AND INFORMATION TO BE ENCODED. LABEL SHALL BE LOCATED ON END OF PALLET COVER ADJACENT TO DESCRIPTIVE NOMENCLATURE.
- M13 IF ACTUAL GROSS WEIGHT IS NOT KNOWN, THE ESTIMATED GROSS WEIGHT FROM ESTIMATED WEIGHT OF PACKAGING COMPONENTS AND PROJECTILES, TABLE 1, SHALL BE USED.

AR 8159

Figure 4-5.1. Palletizing (FAPP) - Metal Pallet.

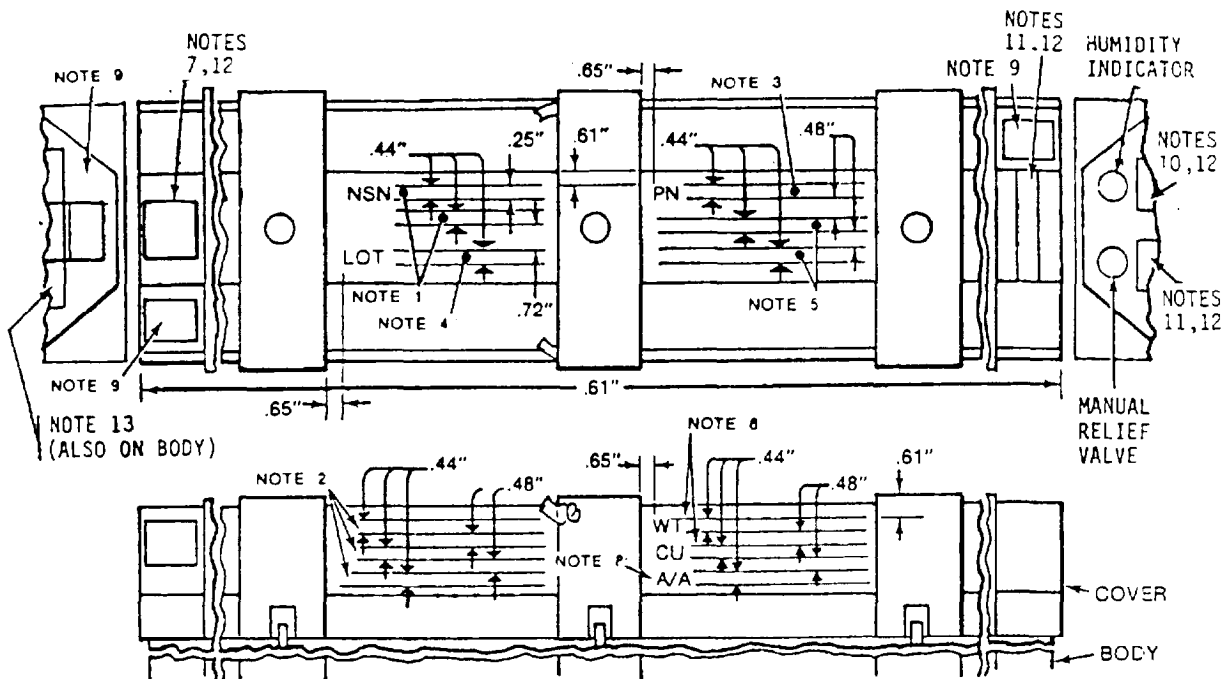

MARKING TABLE					SHIPPING AND STORAGE INFORMATION	
PACKING ASSY. PART NO.	NOMENCLATURE	NSN	PROJECTILE PART NO.	DOT	EXPLOSIVE HAZARD CLASS	STORAGE COMPATIBILITY
9305335-1	1-PROJECTILE 155MM: HEAT CANNON LAUNCHED GUIDED M712	1320-01-077 -4279-D510	9305300	EXPLOSIVE PROJECTILE	1.1	D
9305335-2	1-PROJECTILE 155MM: TRAINING M823 (INERT)	1320-01-077 -4278-D511	9329721	-	-	-

***NOTES:**

1. National Stock No. and DOD Identification Code (see Marking Table).
 2. Nomenclature.
 3. Projectile Part No. (see Marking Table).
 4. Lot No. and Year of Manufacture (last 2 digits only).
 5. DOT (see Marking Table).
 6. Gross weight and cubical displacement.
 7. Method II Label, NSN 7540-00-139-4738, approximately as shown (M712 only).
 8. Show level of packaging and packing, month and year packed.
 9. Four bronze patches (M823 trainer only). Size of patches 2 in. square, except end patches may be reduced in size to fit space, but will be no smaller than 1-1/4 in. square.
 10. "Humidity Indicator" decal.
 11. "Manual Relief Valve" decal.
 12. Decals/labels in Notes 7, 10, 11, and 13 may be missing.
 13. "Retain as Matched Set" decals on body and cover. New production has stamping or stenciling.
- *Container color is forest green. Distinguishing markings for M712 Projectile are yellow; for M823 Projectile are white.

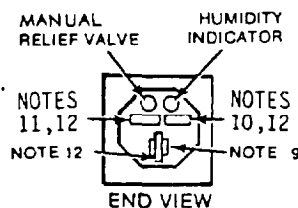

U
AR 5859

Figure 4-6. Marking on Copperhead metal containers.

Section VI. MAINTENANCE OF COPPERHEAD ITEMS

4-21. M712 and M823 Projectiles

a. M712 Projectile in Container.

(1) When projectile is out of container under 30 days, reissue as serviceable ammunition; over 30 days, sent to Anniston AAD.

(2) Unserviceable container.

(a) Repackage projectile in serviceable spare container, following repackaging procedures in TM 9-1300-251-20.

(b) Forward unserviceable container to Depot for repair or disposal.

(3) Projectile requiring touchup, painting, or marking. Perform maintenance as directed in Section V.

(4) Every 90 days, check humidity indicator card in container. If 40 percent sector of card is not blue, change card and desiccant as instructed in paragraph 4-9d.

b. M823 Projectile.

(1) Perform required touchup, painting or markings as directed in section V.

(2) Replace following parts as required, following procedures in TM 9-1300-251-20:

(a) Code and time switches,

(b) Ogive (nose cone).

(c) Obturator and/or base.

4-22. Metal Containers

a. Unserviceable container (unrepairable at DS/GS level). Forward to Depot for repair or disposal.

b. Unserviceable container that can be made serviceable at DS/GS level. Perform required maintenance as directed in section III or section V.

c. Store serviceable spare containers for reuse in repackaging rounds from unserviceable containers.

4-23. Pallets

a. Store serviceable pallets for reuse.

b. Repair unserviceable repairable pallets as directed in TM 9-1300-251-20.

c. Unserviceable unrepairable pallets will be disposed of in accordance with applicable SOP.

Section VII. PROCEDURE FOR WINDSHIELD TIP INSPECTION FOR CARTRIDGE 120MM M829 AND M829A1

4-24. Windshield Tip Runout Gaging/
Acceptance Gaging for Cartridge
M829.

a. Description of Operation for Runout Gaging.

(1) Remove cartridge from shipping container.

(2) Position cartridge between "V" blocks.

(3) Electrically ground cartridge case base.

WARNING

● **ALCOHOL AND ACETONE ARE HIGHLY FLAMMABLE (FLASH POINT OF LESS THAN 100°F); KEEP AWAY FROM HEAT, SPARKS, AND OPEN FLAME; KEEP CONTAINER CLOSED; USE WITH ADEQUATE VENTILATION AVOID PROLONGED REPEATED BREATHING OF THE VAPORS.**

● **DO NOT ALLOW ACETONE TO COME IN CONTACT WITH THE COMBUSTIBLE CARTRIDGE CASE.**

NOTE

APFSDS-T Ammunition must be grasped by the Sabot – NOT THE WINDSHIELD.

- (4) Using a rag dampened with acetone, thoroughly clean windshield tip and tip area of subprojectile.
- (5) Place cap/probe assembly range selector switch of runout gage on 0.012 position. (Meter scale reads -0.012 inch to +0.012 inch for a total of 0.024 inch.)

NOTE

If flush pin member cannot be properly seated on windshield of subprojectile. mark cartridge as "WINDSHIELD UNSERVICEABLE".

- (6) Seat flush pin member of runout gage on windshield, with knurled end toward aft of cartridge.

NOTE

Assure that the indicator needle is resting within the scale limits. Adjust, if necessary, using "Zero" knob.

- (7) Place cap/probe assembly into flush-pin member of gage.

NOTE

While rotating cap/probe assembly, total runout indicator reading must not exceed 0.020 inch (0.50mm).

- (8) Completely rotate cap/probe assembly about windshield tip, hold flush pin member firmly in place.

NOTE

Cartridge shall undergo two attempts at windshield tip replacement.

- (9) Remove runout gage from subprojectile.
- (10) If windshield fails runout gage for the first time, mark base of cartridge "1" indicating first attempt. If windshield tip fails runout gage for the second time, mark "Unserviceable".

b. Description of Operation for Acceptance Gaging.

- (1) Remove cartridge from shipping container.
- (2) Place cartridge in vertical position on felt padded worktable (protect primer) tip pointing upward.

NOTE

APFSDS-T Ammunition must be grasped by the Sabot – NOT THE WINDSHIELD.

- (3) Electrically ground cartridge case base.

WARNING

- **ALCOHOL AND ACETONE ARE HIGHLY FLAMMABLE (FLASH POINT OF LESS THAN 100°F); KEEP AWAY FROM HEAT, SPARKS, AND OPEN FLAME; KEEP CONTAINER CLOSED; USE WITH ADEQUATE VENTILATION; AVOID PROLONGED REPEATED BREATHING OF THE VAPORS.**
- **DO NOT ALLOW ACETONE TO COME IN CONTACT WITH THE COMBUSTIBLE CARTRIDGE CASE.**

- (4) Using a rag dampened with acetone, thoroughly clean windshield tip and tip area of subprojectile.
- (5) Set flush pin handle in upper position of bayonet slot (fig. 4-7).
- (6) Slide Tip Acceptance Gage housing over windshield and windshield tip.
- (7) Release the flush pin handle, let flush pin drop to assure that the tip goes through the flush pin-hole (small diameter, 0.157 inch).

NOTE

The acceptable windshield tip must meet both the following requirements: The tip must go through the flush-pin hole and the flush pin top surface below the upper step and above the lower step of the gage housing. Otherwise, mark "Unserviceable Windshield Tip" on cartridge case and case base.

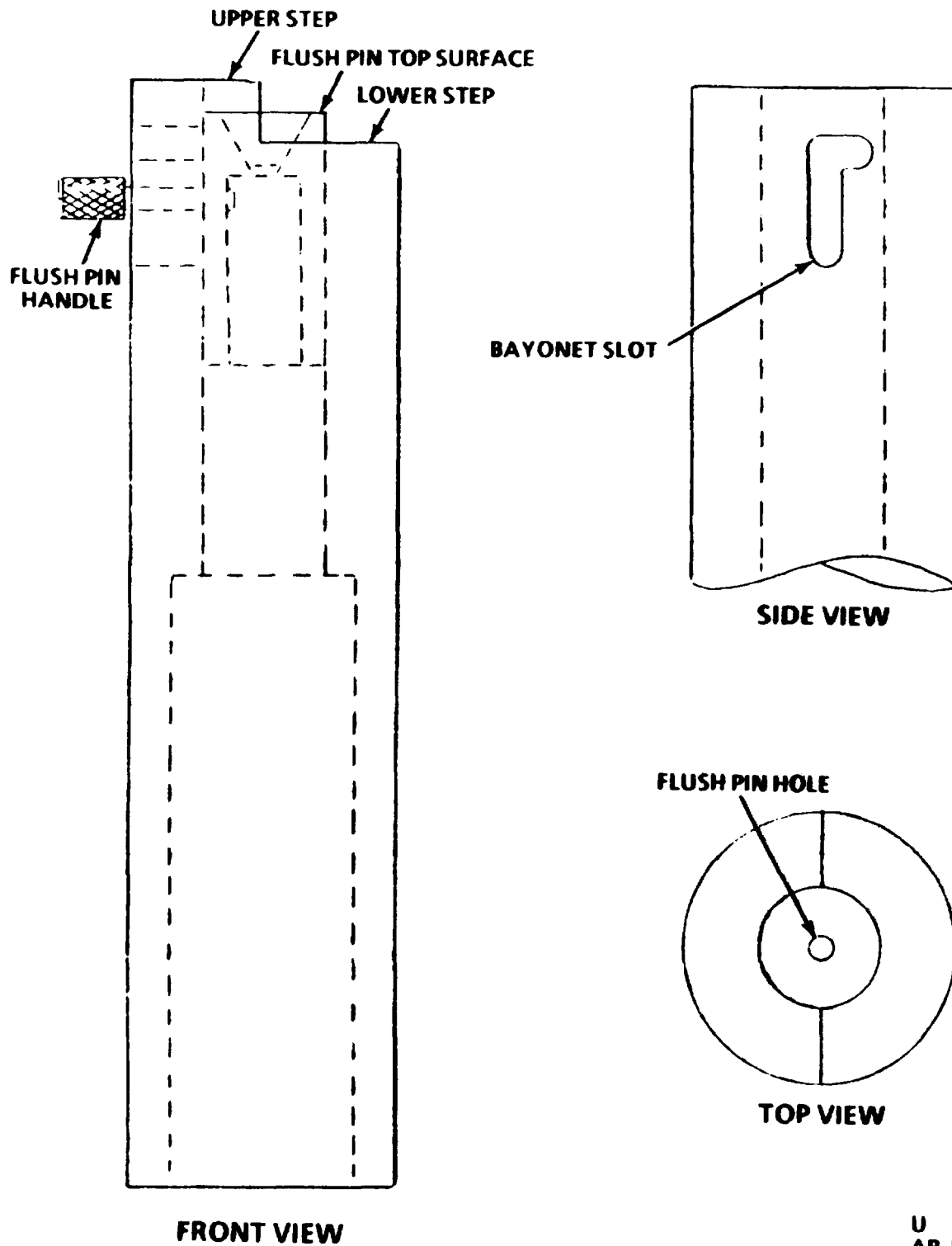

Figure 4-7. Cartridge M829 tip acceptance gage, flush pin type.

- (8) Remove Tip Acceptance Gage from projectile.
- (9) If windshield tip fails acceptance gage for the first time, mark base of cartridge "1" indicating first attempt. If windshield tip fails acceptance gage for the second time, mark "Unserviceable".

c. Tools and Equipment.

- (1) Approved can, flammable waste.
- (2) Coveralls, explosive handlers, flame retardant.
- (3) Runout gage, windshield tip, Honeywell Drawing No. 12525609-GLA,

Government Drawing No. 12525683, NSN: 5220-01-352-9297).

(4) M829 Tip Acceptance Gage, flush pin type, Government Drawing No. 12900341, NSN: 5220-01-352-9298 (gage); NSN: 5220-01-352-1039 (carrying case).

(5) Shoes, safety, conductive.

(6) "V" blocks, locally fabricated, 2 x 6 with a 7 inch opening by 90 degrees.

d. Expendable Supplies.

- (1) Acetone, technical grade.
- (2) Cotton cloth rugs.

Section VIII. PROCEDURE FOR USING 120MM RING GAGES

4-25. 120 mm Ring Gages.

a. Obturator Ring Gage for Cartridge M829 and M829A1. Description of operation is as follows:

- (1) Remove cartridge from shipping container.
- (2) Place cartridge in vertical position on felt padded work table (protect primer) with top pointed upward.
- (3) Wipe cartridge with a clean cloth.
- (4) Pass the obturator ring gage over the forward bourrelet and seat the gage gently on the obturator (fig. 4-8, view a).

(5) Cartridge is acceptable if front surface of rear bourrelet is flush or above flush with front surface of ring gage (fig. 4-8, view b).

NOTE

If front surface of rear bourrelet is not flush or above on the first attempt, rotate gage 90 degrees horizontally. If second attempt fails, mark projectile "Unserviceable - Failed Obturator Ring Gage".

NOTE

Hold gage firmly and assure front surface of gage is in horizontal position.

- (6) Remove obturator ring gage from projectile.
- (7) Pack acceptable cartridge into shipping container.
- (8) Pack unserviceable cartridges in containers marked "Unserviceable - Failed Obturator Ring Gage".

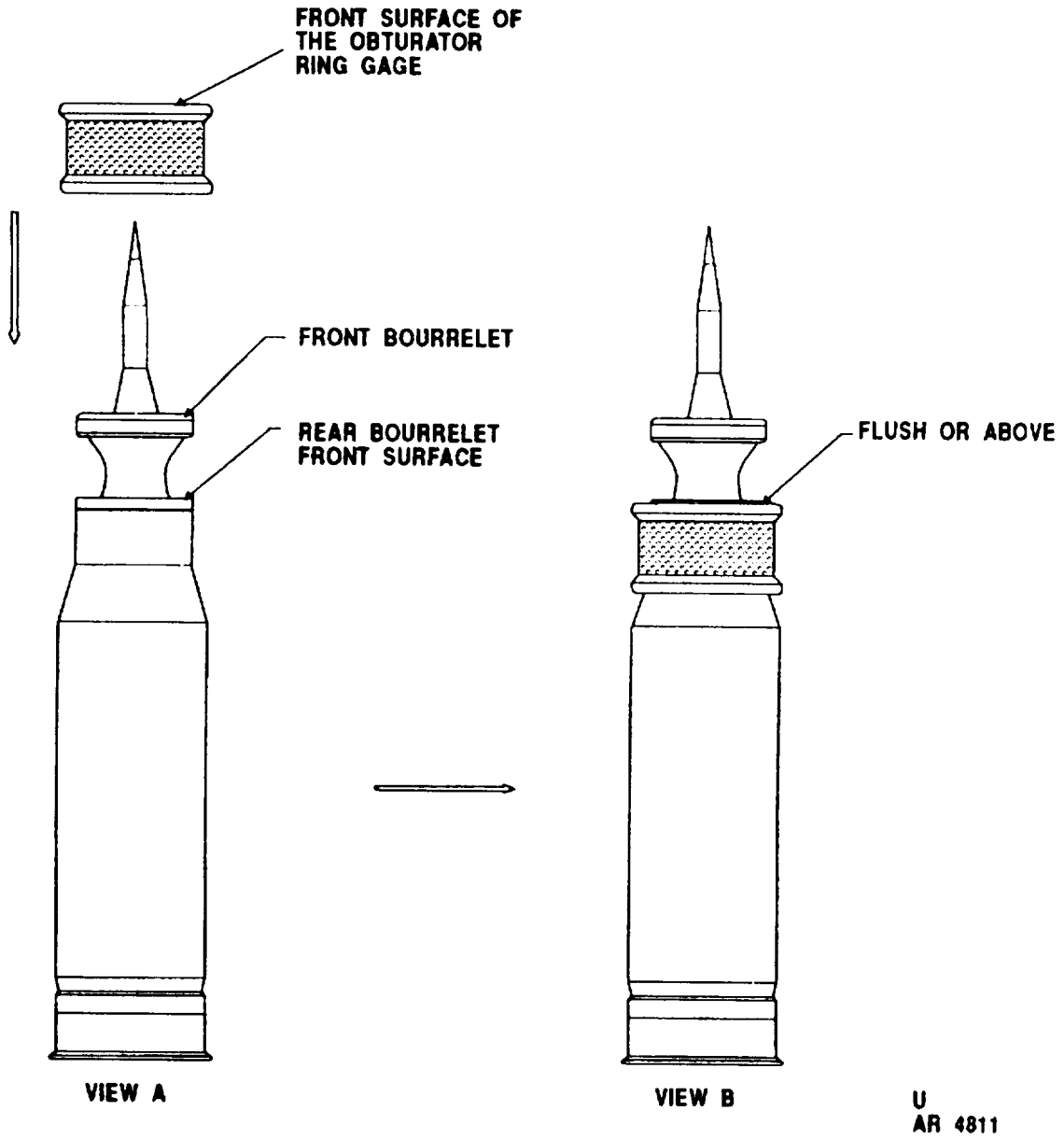

Figure 4-8. Obturator ring gage.

h. Bourrelet Ring_Gage for HEAT and KE Round.

(1) Description of Operation for HEAT Round.

- (a) Remove cartridge from shipping container.
- (b) Place cartridge in vertical position on felt padded work table (protect primer) spike pointing upward.
- (c) Wipe cartridge with a clean cloth.
- (d) Apply bourrelet ring gage over the bourrelet and pass gage slowly down to the copper band (fig. 4-9).

CAUTION

IMPROPER USING OF THIS GAGE MAY CAUSE DAMAGE TO THE SPIKE NOSE OR PROJECTILE BODY.

NOTE

Hold gage firmly and assure front surface of gage is in horizontal position.

- (e) Cartridge is acceptable if ring gage passes bourrelet down to copper band.

NOTE

If ring gage did not pass forward bourrelet on first attempt, rotate gage 90 degrees horizontally. If second attempt fails, mark projectile "Unserviceable - Failed Bourrelet Ring Gage".

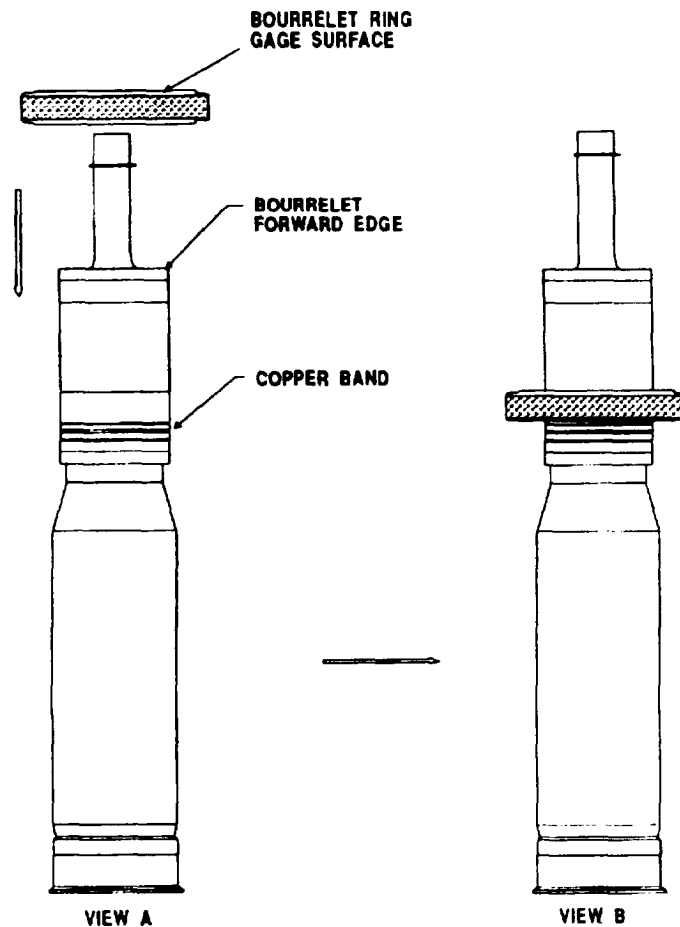

U
AR 4812

Figure 4-9. Bourrelet ring gage.

- (f) Remove obturator ring gage from projectile.
 - (g) Pack acceptable cartridge into shipping container.
 - (h) Pack unserviceable cartridges in container marked "Unserviceable - Failed Bourrelet Ring Gage".
- (2) KE Round. For KE round, Front and Rear Bourrelet (Optional).

NOTE

The bourrelet ring gage may be used on KE cartridges following above procedure. The cartridge is acceptable if ring gage passes from and rear bourrelets down to obturator.

c. Cartridge Case Ring Gage. Description of Operation for all 120mm Tank Cartridges.

- (1) Remove cartridge from shipping containers.
- (2) Place cartridge in vertical position on felt padded work table (protect primer) projectile upward.
- (3) Wipe cartridge with a clean cloth.
- (4) Slowly pass ring gage over the cartridge case down to the rubber seal of the metal case base.

CAUTION

IMPROPER USE OF THIS GAGE MAY DAMAGE THE COMBUSTIBLE CARTRIDGE CASE COATING.

NOTE

Hold gage firmly and assure front surface of gage is in horizontal position.

- (5) Cartridge is acceptable if ring gage should pass down to rubber seal of metal case base (fig. 4-10).

NOTE

If ring gage fails to pass down to rubber seal, measure distance from rear face of case base to position where gage stops. Mark cartridge "Over-size at the measured Distance".

- (6) Remove cartridge case gage from cartridge.
- (7) Pack acceptable cartridge in shipping container.
- (8) Pack unserviceable cartridges in containers marked "Over-size at X inch Distance".

d. Maintenance Requirements for 120mm Ring Gages.

- (1) Using a clean cloth, wipe or clean inside surface of the gage after each round gaged.

WARNING

- **ALCOHOL AND ACETONE ARE HIGHLY FLAMMABLE (FLASH POINT OF LESS THAN 100°F); KEEP AWAY FROM HEAT, SPARKS, AND OPEN FLAME; KEEP CONTAINER CLOSED; USE WITH ADEQUATE VENTILATION; AVOID PROLONGED REPEATED BREATHING OF THE VAPORS.**
- **DO NOT ALLOW ACETONE TO COME IN CONTACT WITH THE COMBUSTIBLE CARTRIDGE CASE.**

- (2) Using a rag dampened with acetone, clean inside surface of the gage after ten rounds are gaged.
- (3) Before storing gage, using a rag dampened with acetone, clean inside surface of gage, then apply one coat of light machine oil on inside surface.

- e. Tools and equipment.
 - (1) Approved can, flammable waste.
 - (2) Carrying case for ring gages, Drawing No. 12900357.
 - (3) Ring gage, obturator, Drawing No. 12900353.
 - (4) Ring gage, bourrelet, Drawing No. 12900351.
 - (5) Ring gage, cartridge case, Drawing No. 12900352.
 - (6) Shoes, safety, conductive.
 - (7) "V" blocks, locally fabricated, 2 x 6 with a 7 inch opening by 90 degrees.
- f. Expendable supplies.
 - (1) Acetone, technical grade.
 - (2) Cotton, cloth rags.

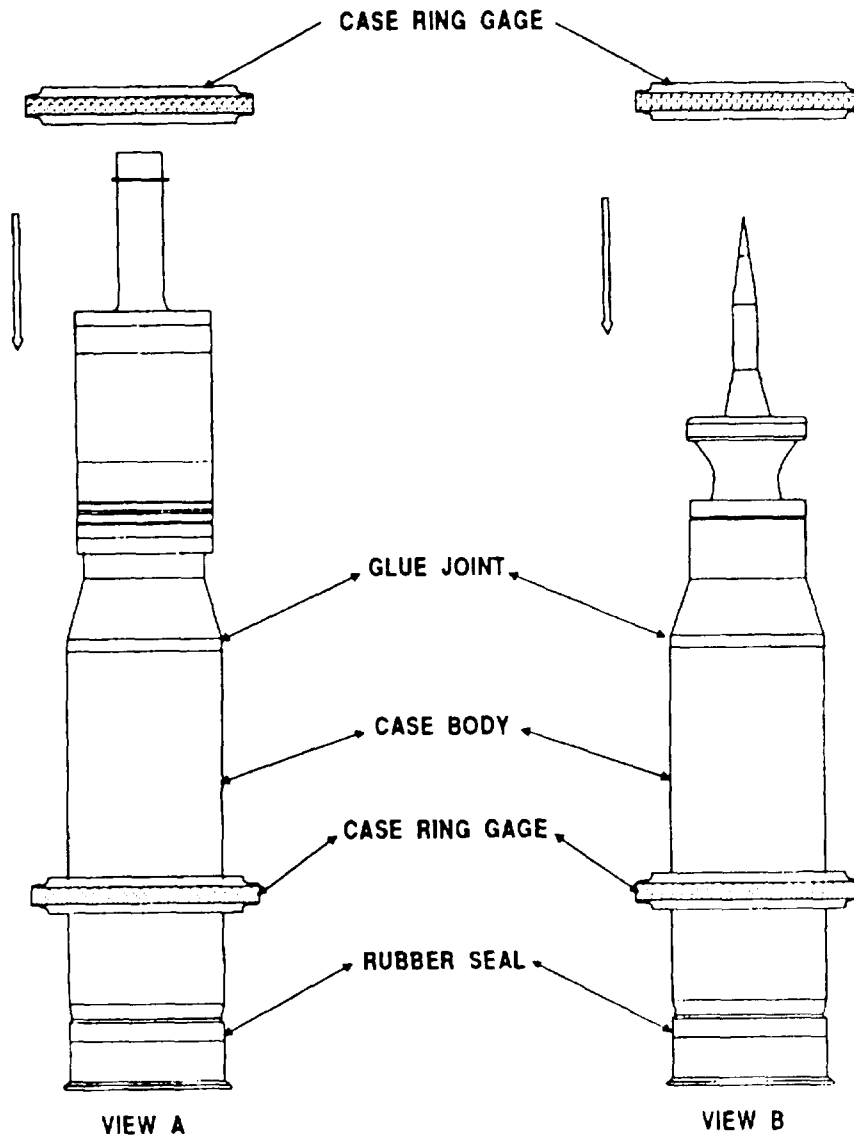

U
AR 4813

Figure 4-10. Case ring gage.

Section IX. PROCEDURE FOR USING 120MM MAN PORTABLE CHAMBER GAGE (MPCG)

4-26. 120mm Tank Ammunition.

a. Operating Instructions for MPCG. Operating instructions are as follows:

- (1) Seat MPCG base stand (fig.4-11) on level ground for stabilization of cartridge. Fix base stand if necessary.
- (2) Ground base stand (screw provided).
- (3) Remove 120mm cartridge (fig.4-12) from shipping container.
- (4) Wipe 120mm cartridge completely with clean cloth, and inspect bourrelet diameter for presence of any burrs.

NOTE

Any burrs on bourrelet diameter may scratch inside surface of MPCG.

- (5) Use the cartridge, 120mm ring gage acceptance set if available, to check bourrelet, obturator, and cartridge case to ensure the maximum diameter of these areas. Then apply MPCG to check the profile/alignment of the cartridge.

CAUTION

Improper use of MPCG may cause damage to cartridge case cover and/or case coating.

NOTE

Hold MPCG vertically and firmly. Do not drop gage over cartridge. Manual force in excess of approximately 60 pounds should not be applied to MPCG.

- (6) Slide MPCG over cartridge until MPCG brass ring contacts case base breech face (fig.4-13). Cartridge is acceptable if metal to metal contact is made between brass base ring and case base breech face.

NOTE

If brass base ring did not contact case base breech face on first attempt, rotate gage 90 degrees, then apply force. If second attempt fails, mark cartridge "FAILED MPCG".

- (7) Remove MPCG from cartridge by holding MPCG base stand and pulling gage upward.
- (8) Pack acceptable cartridge into shipping container.
- (9) Pack unacceptable cartridge into shipping container and mark "FAILED MPCG". Set aside for reinspection by ring gages and/or standard measurement equipment.

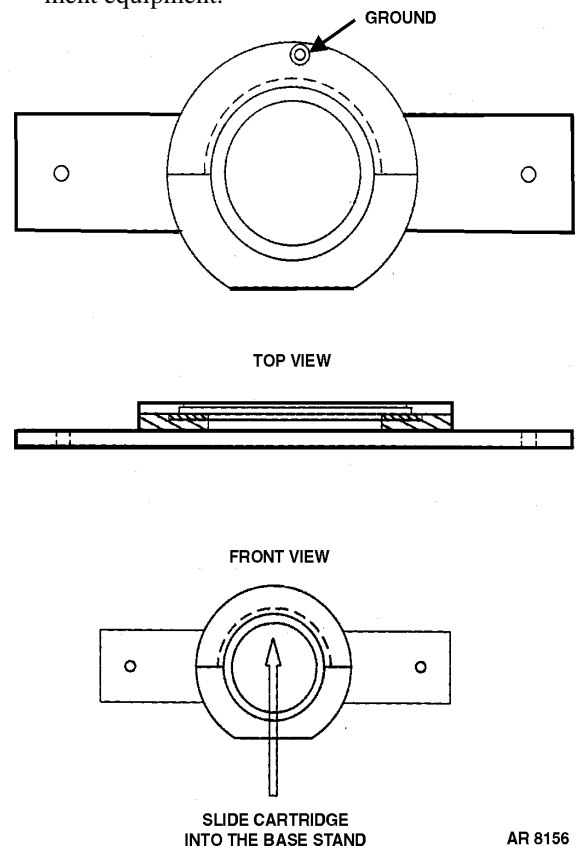

AR 8156

Figure 4-11. MPCG base stand.

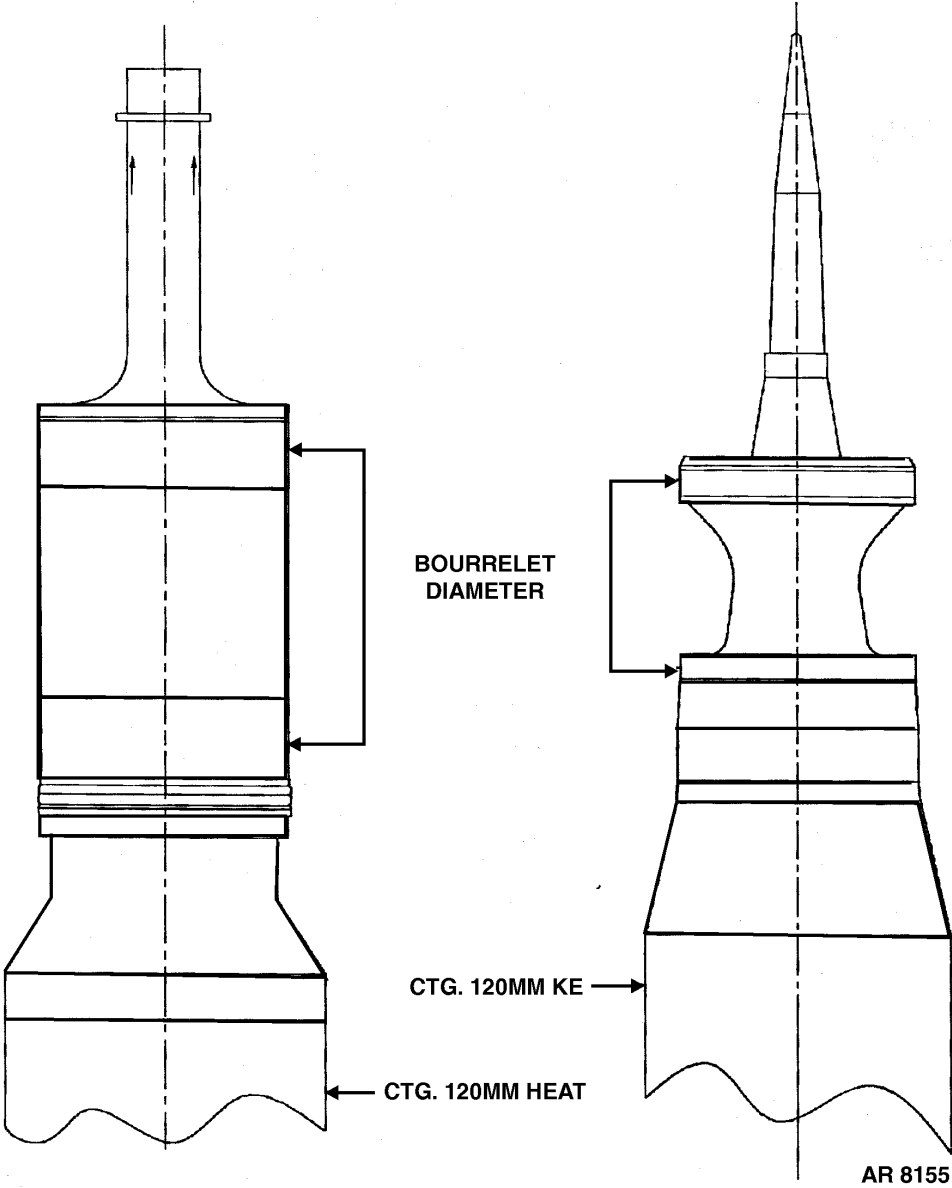

Figure 4-12. Cartridge, 120mm KE/HEAT Bourrelet diameter.

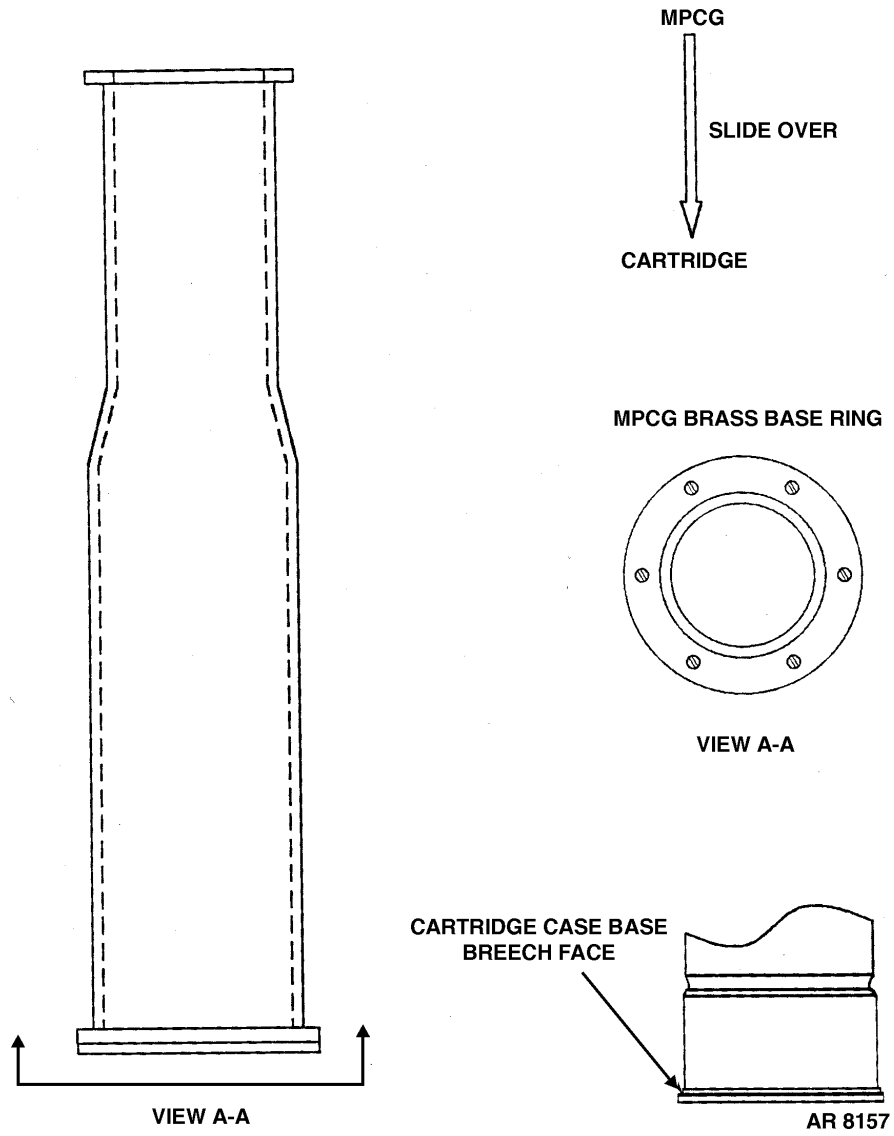

Figure 4-13. Man Portable Chamber Gage (MPCG)

- b. Maintenance Requirement for 120mm MPCG
Description of operation is as follows:

- (1) Wipe or clean inside surface of gage as often as required using a clean cloth.
- (2) Visually inspect the gage inside diameter (projectile contact area) after MPCG is used to gage 5000 cartridges. If excessive wear or physical damage is indicated, a dimensional inspection should be performed in accordance with drawing 12948080 using standard measuring equipment. All other dimensions are tool-controlled and need not be gaged. Visual inspection should be performed every 1000 cartridges thereafter.

NOTE

Use form QA-1 to report dimensions.

- (3) Inspect for damage to brass ring on gage

- c. Tools and Equipment.

- (1) Container and cushion assembly for 120mm Man Portable Chamber Gage (MPCG) and Base Stand. Drawing No. 12948085. NSN: 5220-01-477-5500.
- (2) Cartridge, 120mm Man Portable Chamber Gage (MPCG). Drawing No. 12948080. NSN: 5220-01-477-5451.
- (3) Cartridge, 120mm MPCG Base Stand. Drawing No. 12948081. NSN: 5220-01-477-5487.
- (4) Cartridge, 120mm MPGC Set. Drawing No. 12948079. NSN: 5220-01-477-5455.

Section X. ALIGNMENT CRITERIA AND PROCEDURE FOR M829A1

4-27. 120MM Cartridge, M829A1.

- a. Penetrator (Sabot/Windshield Marks) Alignment Accept/Reject Criteria for M829A1. Criteria for M829A1 is as follows:

NOTE

Two marking schemes are used for the Accept/Reject criteria. Refer to fig. 4-14.
Scheme I - Figures A thru E.
Scheme II - Figures F thru H.

- (1) If marks on sabot/windshield interface are as shown in figure A, B, C or F, the cartridge is acceptable. For figure F, the mark on the windshield should be between and not overlap with the marks on the sabot.
- (2) If marks on sabot/windshield interface are as shown in figure D, E, G or H, the cartridge must be aligned (follow Sabot/Windshield Marks Alignment Procedure as shown in para b) as shown in figure A, B, C, or F. If the cartridge can not be acceptably realigned, it shall be rejected and turned in.

- b. Sabot/Windshield Marks Alignment Procedure for M829A1. Procedure for alignment of M829A1 is as follows:

- (1) Place cartridge with primer protective cover (cardboard) on level ground with windshield tip pointing up.
- (2) Grasp sabot area firmly with one hand, and with the other hand rotate the windshield relative to the sabot segments as follows:
 - (a) If alignment marks at the sabot/windshield interface are as shown in figure D or G, rotate windshield clockwise until alignment marks align as shown in figure B (preferable), or A or figure F.
 - (b) If alignment marks at the sabot/windshield interface are as shown in figures E and H, rotate windshield counter-clockwise until alignment marks align as shown in figure B (preferable), C or figure F.

PENETRATOR ALIGNMENT ACCEPT/REJECT CRITERIA FOR M829A1:

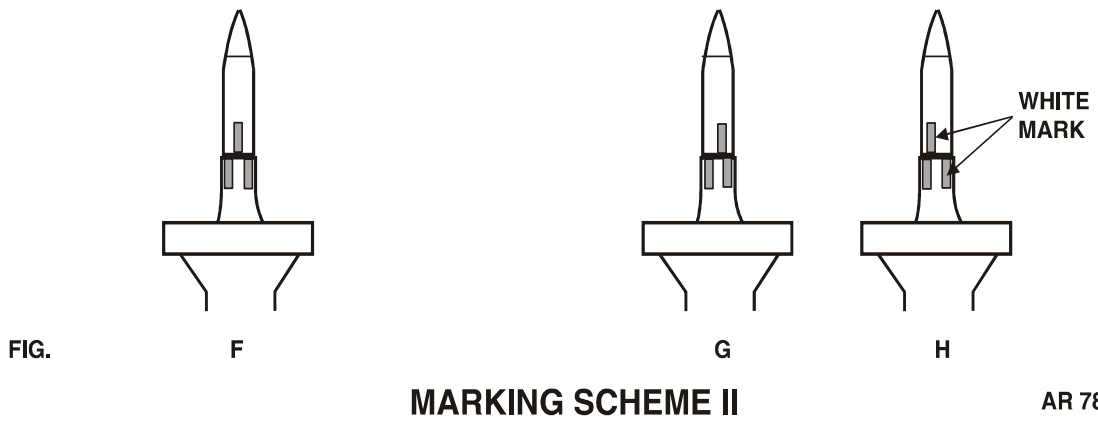
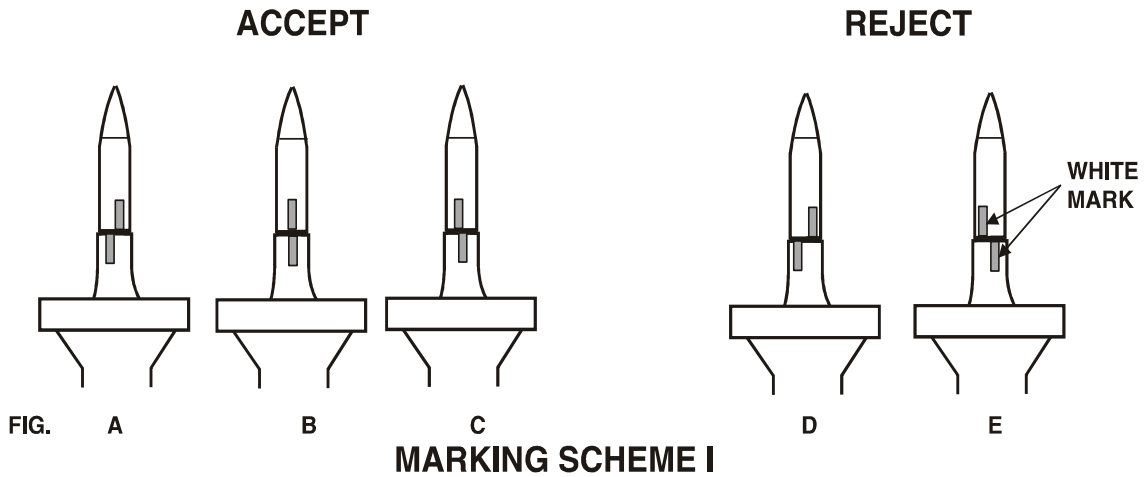

Figure 4-14. Sabot/Windshield marking schemes.

Section XI. PROJECTILE ALIGNMENT ACCEPT/REJECT CRITERIA FOR M1028

4-28. Alignment Criteria for M1028 Projectile

NOTE

If witness lines are not present, crew members should grasp both the forward and aft bodies with hands and attempt to turn them in opposite directions. If any movement of the projectile body relative to the aft body is detected, the cartridge shall be rejected and turned into the Ammunition Supply Point (ASP).

a. The white witness lines (if present) on the forward body and the aft body interface are as shown in figure 4-15. The cartridge is acceptable if the marks on the forward body and the aft body are perfectly aligned (see accept criteria).

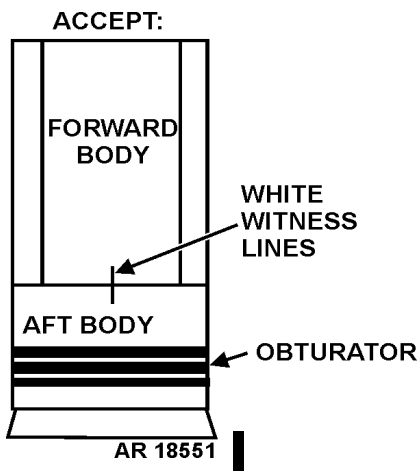

Figure 4-15. Acceptable Cartridge for M1028.

b. If the white witness lines on forward body shift to left or right away from the white witness lines on the aft body or out of radial alignment as shown in figure 4-16, the cartridge shall be rejected and turned in.

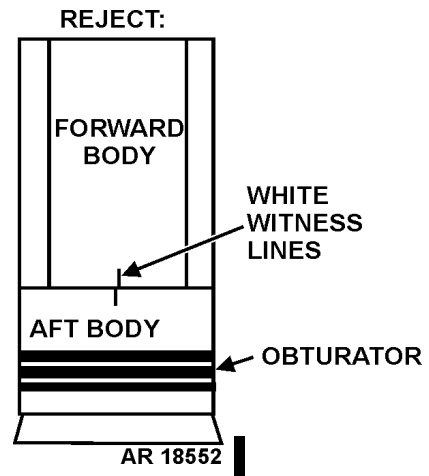

Figure 4-16. Unacceptable Cartridge for M1028.

THIS PAGE INTENTIONALLY LEFT BLANK

**APPENDIX A
REFERENCES**

A-1. SCOPE

This appendix lists all forms, pamphlets, regulations, field manuals, and technical manuals referenced in this manual, DA Pam 25-30 should be consulted frequently for latest changes or revisions of references given in this appendix and for new publications relating to the material covered in this manual,

A-2. BLANK FORMS

Recommended Changes to Publications and Blank Forms DA Form 2028
 Ammunition Condition Report DA Form 2415

A-3. DA PAMPHLETS

Consolidated Index of Army Publications and Blank Forms DA Pam 25-30
 The Army Maintenance Management System (TAMMS) DA Pam 738-750

A-4. ARMY REGULATIONS

Ammunition Stockpile Reliability Program (ASRP) AR 702-6
 Quality Assurance Specialist (Ammunition Surveillance Subscription Form) AR 702-12
 Storage and Supply Activity Operations AR 740-1

A-5. FIELD MANUALS

Conventional Ammunition Maintenance Unit Operations FM 9-19

A-6. TECHNICAL MANUALS

Ammunition, General TM 9-1300-200
 Ammunition and Explosives Standards TM 9-1300-206
 Ammunition Maintenance TM 9-1300-250
 Organizational Maintenance Manual (Incl RPSTL) Artillery Ammunition
 for Guns, Howitzers, Mortars, Recoilless Rifles and 40mm
 Grenade Launchers TM 9-1300-251-20

A-7. SUPPLY BULLETINS

Ammunition Surveillance Procedures SB 742-1

A-8. SUPPLY CATALOGS

Shop Equipment, Ammunition Renovation: Field Maintenance Detachment, Less Power (4925-754-0710) (Line Item W59719) and Shop Equipment, Ammunition Renovation: Field Maintenance Detachment, MAP only (4925-919-0067) SC 4925-95-CL-A03

A-8. SUPPLY CATALOGS - Continued

Tool Set, Ammunition: Field Maintenance, Ordnance Ammunition Company (4940-322-6058) (Line Item W59582 Formerly Line Item 454628) and Tool Set Ammunition: Field Maintenance, Ordnance Ammunition Company MAP only (4940-919-0113) SC 4940-95 -CL-A11

APPENDIX B

DIRECT SUPPORT AND GENERAL SUPPORT PACKING MATERIALS, ACCESSORIES, AND TOOLS

Section I. INTRODUCTION

B-1. Scope

This appendix lists packing materials, accessories, and tools required for the performance of direct support and general support maintenance of artillery ammunition for guns, howitzers, mortars, recoilless rifles, and 40mm grenade launchers.

B-2. General

This appendix is divided into the following sections:

a. Section II - Packing Materials. A list of packing materials authorized for the performance of maintenance at the direct support and general support levels.

b. Section III - Special Packing Tools List. A list of special tools and accessories authorized for the performance of maintenance at the direct support and general support levels.

B-3. Explanation of Columns

The following provides an explanation of columns in Section II and III.

a. Part Number (Drawin Number). The primary number used by the manufacturer which controls the design and characteristics of the item. Drawings can be obtained from originating source (see CAGE Code).

b. Contractor and Government Entity Code (CAGEC) - (Formerly known as Federal Supply Code for Manufacturers (FSCM)). A five-digit code used to identify the manufacturer, distributor, or Government agency/activity that supplies the item.

c. Figure Number. The number of the figure where the item is identified/located.

d. Description. The Federal item name and any additional description of the item required.

Section II. PACKING MATERIALS - Continued

PART NO. DWG NO.	CAGE CODE	FIGURE NO.	DESCRIPTION
			FIXED AMMUNITION (EXCEPT 152MM) CARTRIDGE (COMPLETE ROUND)
			35MM
1910292	19200		CONTAINER, METAL, AMMUNITION: for Cartridge, 35-MM, TP-T. M968
			40MM
12597938	19200		BOX, FIBERBOARD: for Cartridge, 40-MM, M918
8335105	19203		BOX, PACKING, AMMUNITION: for Cartridges, 40-MM, M381, M382, M386, M406, M433, M470A1, M441, M576
8335104	19203		BOX, PACKING, AMMUNITION: for Cartridges, 40-MM, M381, M382, M386, M406, M433, M470A1, M441, M576
8882362	19203	4-1	BOX, PACKING, AMMUNITION: for Cartridge, 40-MM, M397.
9209205	19203		BOX, PACKING, AMMUNITION: for Cartridges, 40-MM, M583, M583A1, M585, M661, M662, M713, M715, M716, M992,
9251995	19203		BOX, PACKING, AMMUNITION: for Cartridges, 40-MM, M383, M384, M385
9251996	19203		BOX, PACKING, AMMUNITION: for Cartridges, 40-MM, M383, M384, M385, M430
12597941	19200		BOX, PACKING, AMMUNITION, WOOD: for Cartridge, 40-MM, M918
8796464	19203		BOX, PACKING, ASSEMBLY: for Container, M66A1 for Cartridges 40- MM, Mk2, M81 Series and M91
5581378	19203	4-1	BOX, WIREBOUND, PACKING, AMMUNITION: for Cartridges, 40-MM, M674, M675
8882363	19203		BOX, WIREBOUND, PACKING, AMMUNITION: for Cartridge, 40-MM, M397
9209204	19200		BOX, AMMUNITION: Metal, M2A1 for Cartridges, 40-MM, M583, M583A1, M585, M661, M662, M713, M715, M716, M992, XM1006
7553315	19203		CHEST, AMMUNITION: Metal. M19A1 for Cartridges, 40-MM, M674, M675
12619468	19203		CONTAINER, AMMUNITION: 40-MM (Sgt York) for Cartridges, 40-MM, M811, M813, M822, M851
76-1-1112	19203		CONTAINER, AMMUNITION: M66A1for Cartridges, 40-MM, Mk2, M81 se- ries and M91
12928042	19200		SHIPPING AND STORAGE CONTAINER, CARTRIDGE: PA-120 for Car- tridges, 40-MM, M385A1, M430, M430A1, M918, M922, M922A1, M1001, Mk281 MOD 0
9362543	19201		SHIPPING AND STORAGE CONTAINER, CARTRIDGE: M548 for Car- tridges, 40-MM, M385, M385A1, M430, M430A1, M918, M922, M922A1

Section II. PACKING MATERIALS - Continued.

PART NO./ DWG. NO.	CAGE CODE	FIGURE NO.	DESCRIPTION
			75MM (cont.)
7549268	19203		BOX, PACKING, AMMUNITION: for Cartridge, 75MM, Blank, M337A2
7549269	19203		CONTAINER, AMMUNITION: M27A2 Fiber for Cartridges, 75MM, Blank, M337, M337A1 M337A1E1
			84MM
	SF413		BARRIER, PLASTIC: Inner packing for AT4 M136
13230238	SF413		BOX, WOODEN: for AT4 M136
4113336	SF413		PALLET: for complete AT4 M136 and AT4 CS RS
	SF413		BARRIER, PLASTIC: Inner packing for AT4 CS RS
3074372	SF413		BOX: Packed, marked AT4 CS RS
41133864	SF413		PALLET: for complete AT4 CS RS
			90MM
7548476	19203		BOX, PACKING, AMMUNITION: for Cartridges, 90MM, M381 Series and M353 Series
7549249	19203		BOX, PACKING, AMMUNITION: for Cartridge, 90MM Blank, M394
76-1-1236	19203		BOX, PACKING, ASSEMBLY: for Cartridges, 90MM, M82, M96A2, consists of Bolt, Carriage, Connector, Filler, and Handle
8796716	19203		BOX, PACKING, AMMUNITION: for Cartridges, 90MM, M371A1 and M371 (M379)
8798641	19203		BOX, PACKING, AMMUNITION: for Cartridge, 90MM, Canister, M377
8800077	19203		BOX, PACKING, AMMUNITION: for Cartridges, 90MM, M431 Series
8887602	19203		BOX, PACKING, AMMUNITION: for Cartridges, 90MM, M348 Series
9213612	19203		BOX, PACKING, AMMUNITION: for Cartridge, 90MM, Canister, M590E1
9213661	19203		BOX, PACKING, AMMUNITION: for Cartridge, 90MM, M580
9215118	19203		BOX, PACKING, AMMUNITION: for Cartridge, 90MM, Canister, M336, for Guns M1A2, M2A1, M1A3, M3, and M36
7548306	19203		BOX, PACKING, AMMUNITION: for Cartridges, 90MM, M12 Series, M71 Series, and M313 Series
76-1-1237	19203		BOX, PACKING, ASSEMBLY: for Cartridges, 90MM, M332 Series, M184A2, consists of Bolt, Carriage, Connector, Filler, Handle, End, Side, and Top
7548301	19203		CONTAINER, AMMUNITION: M53A4 for Cartridges, 90MM, M12, M71, M313, M12B2, T94, T94A2, M71A1, and M7364
7548467	19203		CONTAINER, AMMUNITION: M180A1 for Cartridges, 90MM, M318A1 and M353A1
7549250	19203		CONTAINER, AMMUNITION: M125A1 for Cartridge, 90MM, Blank, M394
76-1-1105	19203		CONTAINER, AMMUNITION: M96A2 for Cartridge, 90MM, M82

Section II. PACKING MATERIALS - Continued.

PART NO./ DWG. NO.	CAGE CODE	FIGURE NO.	DESCRIPTION
			90MM (cont.)
76-1-1106	19203		CONTAINER, AMMUNITION: M184A2 for Cartridges, 90MM, M332 Series, M317A2, M304, M332B1A1, M332A1, and M33 Series
8796717	19203		CONTAINER, AMMUNITION: PA 56 for Cartridges, 90MM, M371A1 and M371
8800078	19203		CONTAINER, AMMUNITION: M411 for Cartridges, 90MM, M431 Series for Guns M39, M54, and M41
8887601	19203		CONTAINER, AMMUNITION: T73E1 for Cartridges, 90MM, M348 and M348A1
9213611	19203		CONTAINER, AMMUNITION: M572 for Cartridge, 90MM, Canister, M590
9213660	19203		CONTAINER, AMMUNITION: M565 for Cartridge, 90MM, M580
9215119	19203		CONTAINER, AMMUNITION: M287 for Cartridge, 90MM, Canister, M336
8798640	19203		CONTAINER, AMMUNITION: M403 fiber for Cartridge, 90MM, Canister, M377
			105MM
8835039	19203		BOX, PACKING, AMMUNITION: for Cartridges, 105MM, M392 Series, M724, M728
8836004	19203		BOX, PACKING, AMMUNITION: for Cartridges, 105MM, M393 Series, M416, M467, M457
8837831	19203		BOX, PACKING, AMMUNITION: for Cartridges, 105MM, M456 series and M490
9204454	19203		BOX, PACKING, AMMUNITION: for Cartridge, 105MM, M494
9293481	19203		BOX, PACKING, AMMUNITION: for Cartridges, 105MM, M735, M774
93221291	19203		BOX, PACKING, AMMUNITION: for Cartridge, 105MM, M456A2
9347387	09871		BOX, PACKING, AMMUNITION: for Cartridge, 105MM, XM833
12551938	19203		CONTAINER, AMMUNITION: Metal, for Cartridge, 105MM, M456A2
8835040	19203		CONTAINER, AMMUNITION: M431 for Cartridges, 105MM, M392 Series, M728
8836005	19203		CONTAINER, AMMUNITION: M451 for Cartridges, 105MM, M393 Series, M416, M467, M457
8837832	19203		CONTAINER, AMMUNITION: M435 for Cartridges, 105MM, M456 Series and M490
9278416	19203		CONTAINER, AMMUNITION: PA72 for Cartridge, 105MM, M724
9293479	19203		BOX, WIREBOUND: for Cartridges, 105MM, M735, M774
9294889	19203		CONTAINER, AMMUNITION: M563A1 for Cartridge, 105MM, M494
9321286	19203		CONTAINER, AMMUNITION: PA 82 fiber for Cartridge, 105MM, M456A2
9347384	19203		CONTAINER, AMMUNITION: Fiber for Cartridge, 105MM, XM833
9378162	19203		CONTAINER, AMMUNITION: PA 117 metal for Cartridge, 105MM, APFSDS-T, M833

Section II. PACKING MATERIALS - Continued.

PART NO./ DWG. NO.	CAGE CODE	FIGURE NO.	DESCRIPTION
			105MM (cont.)
12910039	19200		CONTAINER, AMMUNITION: PA117 metal for Cartridge, 105MM, APFSDS-T, M900
888393- PACK	1WXN1		CONTAINER, AMMUNITION: PA117 metal for Cartridge, 105MM, HEP-T, M393A3
888467 PACK	1WXN1		CONTAINER, AMMUNITION: PA117 metal for Cartridge, 105MM, TP-T, M467A1
28073029	1PYT8		CONTAINER, AMMUNITION: PA117 metal for Cartridge, 105MM, Canister, M1040
9345252	09781		CONTAINER, AMMUNITION: metal for Cartridge, 105MM, M833
9349242	09781		CUSHION, WINDSHIELD: for Cartridge, 105MM, M833
			106MM
7548963	19203		BOX, PACKING, AMMUNITION: for Cartridge, 106MM, M344A1
7549070	19203		BOX, PACKING, AMMUNITION: for Cartridges, 106MM, M344A1, M368
9212554	19203		BOX, PACKING, AMMUNITION: for Cartridge, 106MM, M581
7548962	19203		CONTAINER, AMMUNITION: M316 for Cartridge, 106MM, M344A1
7549071	19203		CONTAINER, AMMUNITION: M314 for Cartridges, 106MM, M364 Series, M386
9212553	19203		CONTAINER, AMMUNITION: M564 for Cartridge, 106MM, M581
			120MM
12527240	19203		BOX, AMMUNITION: for Cartridges, 120MM, M831 and M865
12527220	19203		CONTAINER, AMMUNITION: fiber for Cartridges, 120MM, M831 and M865
12913178	19200		CONTAINER, AMMUNITION: PA116 metal for Cartridges, 120MM, TPCSDS-T, M865 w/ short Sabot
9386832	19200		CONTAINER, AMMUNITION: PA116 metal for Cartridge, 120MM, APFSDS-T, M829
12527436	19200		CONTAINER, AMMUNITION: PA116 metal for Cartridge, 120MM, APFSDS-T, M829A1
12944282	19200		CONTAINER, AMMUNITION: PA116 metal for Cartridge, 120MM, APFSDS-T, M829A2
12990738	19200		CONTAINER, AMMUNITION: PA171 IM, metal for Cartridge, 120MM, APFSDS-T, M829A3
12912369	19200		CONTAINER, AMMUNITION: PA116 metal for Cartridge, 120MM, HEAT-MP-T, M830A1
9386833	19200		CONTAINER, AMMUNITION: PA116 metal for Cartridge, 120MM HEAT-MP-T, M830, TP-T, M831, M831A1
12984588	19200		CONTAINER, AMMUNITION: PA116 metal for Cartridge, 120MM, HE-OR-T, M908
13006757	19200		CONTAINER, AMMUNITION: PA171 IM, metal for Cartridge, 120MM: TPMP-T, M1002
13011576	19200		CONTAINER, AMMUNITION: PA171 IM, metal for Cartridge, 120MM: Canister, M1028
			165MM
8796482	19203		BOX, PACKING, AMMUNITION: for Cartridges, 165MM, M123 Series, M623
8796483	19203		CONTAINER, AMMUNITION: M387A1 for Cartridges, 165MM, M123 Series, M623

Section II. PACKING MATERIALS - Continued.

PART NO./ DWG. NO.	CAGE CODE	FIGURE NO.	DESCRIPTION
			FIXED AMMUNITION (152MM ONLY) CARTRIDGE (COMPLETE ROUND)
9212118	19203		BOX, PACKING, AMMUNITION: for Cartridges, 152MM, M409 Series, M411 Series, and APERS-T, XM617
9224909	19203		BOX, PACKING, AMMUNITION: for Cartridges, 152MM, M625 Series and M657
9229158	19203		BOX, PACKING, AMMUNITION: for Dummy Cartridge, 152MM, M596
9212119	19203		CONTAINER, AMMUNITION: M556A1 for Cartridges, 152MM, M409 Series and M411 Series
9221407	19203		CONTAINER, AMMUNITION: M580A1 for Cartridge, 152MM, M625 Series
9224908	19203		CONTAINER, AMMUNITION: PA33 for Cartridge, 152MM, M657 (XM 657E2)
			PROJECTILE ASSEMBLY Not applicable
			PROPELLING SYSTEM Not applicable
			SEMIFIXED AMMUNITION (EXCEPT MORTAR) CARTRIDGE (COMPLETE ROUND)
7549072	19203		BOX, PACKING, AMMUNITION: for Cartridges, 105MM, M1, M60, M84 Series, M314 Series, M327, M360, M413, M444, XM629, M14
7549254	19203		BOX, PACKING, AMMUNITION: for Cartridge, 105MM, Blank, M396
8862347	19203		BOX, PACKING, AMMUNITION: for Cartridge, 105MM, M472

Section II. PACKING MATERIALS - Continued.

PART NO./ DWG. NO.	CAGE CODE	FIGURE NO.	DESCRIPTION
			SEMIFIXED AMMUNITION (EXCEPT MORTAR) CARTRIDGE (COMPLETE ROUND) (cont.)
9213637	19203		BOX, PACKING, AMMUNITION: for Cartridge, 105MM, M548E1
7549073	19203		CONTAINER, AMMUNITION: M105A3 for Cartridges, 105MM, M1, M60, M84 Series, M314 Series, M327, M360, M413, M444, XM629, M14
7549256	19203		CONTAINER, AMMUNITION: M34A1 for Cartridge, 105MM Blank, M396
8862348	19203		CONTAINER, AMMUNITION: M472 for Cartridge, 105MM, M546
9213636	19203		CONTAINER, AMMUNITION: M547 for Cartridge, 105MM, M548
9378166	19203		CONTAINER, AMMUNITION: PA117 metal for Cartridge, 105MM, HERA M913, ILLUM, M314A3, M915
			FUZE
9204223	19203		BOX, AMMUNITION: for Fuzes, Proximity, M513, M514, T368E2, M728
8861213	19203		BOX, PACKING, AMMUNITION: for Fuzes, M78, M524, M557, M572, M565, M501, M564, M739, M732, M732 Series, M762 Series, M767 Series, MK399 MOD 1
8864492	19203		BOX, PACKING, AMMUNITION: Metal for Fuzes, M78, M524, M557, M572, M565, M501, M584, M577, M739, M732, MK399 MOD 1, M782, M762 Series, M767 Series
8865546	19203		BOX, PACKING, AMMUNITION: for Fuzes, Proximity, M513, M514, M532

Section II. PACKING MATERIALS - Continued.

PART NO./ DWG. NO.	CAGE CODE	FIGURE NO.	DESCRIPTION
			SEMIFIXED AMMUNITION (MORTAR ONLY) CARTRIDGE (COMPLETE ROUND)
			4.2 INCH
7549248	19203		BOX, PACKING, AMMUNITION: for Cartridges 4.2 Inch, M3 Series, M328 Series, M329 Series, M335 Series and M630
76-1-1188	19203		BOX, PACKING, ASSEMBLY: for Cartridges, 4.2 Inch, M243 Series, Gas and Smoke
7549247	19203		CONTAINER, AMMUNITION: M251A1 for Cartridges, 4.2 Inch, M3 Series, M328 Series, M329 Series, M335 Series and M360
76-1-1189	19203		CONTAINER, AMMUNITION: M243 for Cartridges, 4.2 Inch, M2 Series, Gas and Smoke
			22MM
9322201	19203		BOX, WIREBOUND, PACKING, AMMUNITION: for Cartridge, Subcaliber, 22MM Practice
9322198	192903		TRAY, ASSEMBLY: for Cartridge, Subcaliber, 22MM Practice
			60MM
9215577	19203		BOX, PACKING, AMMUNITION: for Cartridge, 60MM, M302 Series
9220015	19200		BOX, PACKING, AMMUNITION: for Cartridges, 60MM, M49 Series, M50A3
9223900	19203		BOX, PACKING, AMMUNITION: for Projectile, 60MM, M69
9242066	19203		BOX, PACKING, AMMUNITION: for Cartridge, 60MM, M83 Series
9317918	19203		BOX, PACKING, AMMUNITION: for Cartridge, 60MM, HE, M720 and Cartridge, 60MM Smoke (WP) M722 and M722A1
9329480	19203		BOX, PACKING, AMMUNITION: for Sabot 60MM Practice, M3 and Sabot 81MM Practice, M1
9354467	19203		BOX, WIREBOUND: for Cartridge, 60MM, Illuminating, M721, Illuminating (IR), M767, HE, M720A1, M768, and M1061
9280108	19203		BOX, WIREBOUND, PACKING, AMMUNITION: for 60MM, Mortar Cartridge
9215576	19203	4-1	CONTAINER, AMMUNITION: M567 for Cartridge, 60MM, M302 Series
9220014	19203	4-1	CONTAINER, AMMUNITION: M576 for Cartridges, 60MM, M49 Series, M50A3
9242065	19203	4-1	CONTAINER, AMMUNITION: PA44 for Cartridge, 60MM, M83 Series
9349695	19203	4-1	CONTAINER, AMMUNITION: for Cartridge, 60MM, Illuminating, M721
12992901	19200		CONTAINER, AMMUNITION, FIBER, PA164: for Cartridge, 60mm: HE, M720A1 and M768
12993655	19200		CONTAINER, AMMUNITION, METAL, PA124 W/Intumescent Coating: For Cartridge, 60mm: HE, M720A1 and M768,
12993728	19200		CONTAINER, AMMUNITION, FIBER, PA165: for Cartridge, 60mm, Full Range Practice, M769
12992898	19200		BOX, WIREBOUND: for Cartridge, 60mm, Full Range Practice, M769

Section II. PACKING MATERIALS - Continued.

PART NO./ DWG. NO.	CAGE CODE	FIGURE NO.	DESCRIPTION
			60MM (Cont.)
9293286	19203	4-1	CONTAINER, AMMUNITION: Fiber for Cartridge, 60MM, HE, M720 and Cartridge, 60MM Smoke (WP) M722 and M722A1
9280110	19203	4-1	CONTAINER, AMMUNITION: PA73 Fiber for Cartridge, 60MM, M888 and M302A2
9354466	19203		CONTAINER, AMMUNITION: PA124 Metal for Cartridge, 60MM, Illuminating, M721, Illuminating (IR), M767, HE, M720A1, M768, and M1061
9280109	19203		CONTAINER, AMMUNITION
9252724	19203		CONTAINER, AMMUNITION, METAL, ASSEMBLY: PA70 for Cartridge, 60MM, HE M720 and Cartridge, 60MM Smoke (WP) M722 and M722A1
13008608	19200		CONTAINER, AMMUNITION, FIBER, PA178: for Cartridge, 60MM, HE, M1061
			81MM
12630600	19203		BOX, PACKING, AMMUNITION: PA149 for Cartridge, 81MM M879
7548995	19203		BOX, PACKING, AMMUNITION: for Cartridge, 81MM, M56 Series and M57 Series
7691562	19203		BOX, PACKING, AMMUNITION: for Projectile, 81MM, M68
8858642	19200		BOX, PACKING, AMMUNITION: for Cartridges, 81MM, Mortar, HE, M43 Series TP, M43A1, M36A5
9230176	19203		BOX, PACKING, AMMUNITION: for Cartridges, 81MM, M362 Series, M374 Series, M375 Series
9241849	19203		BOX, PACKING, AMMUNITION: for Cartridges, 81MM, M301 Series
9329480	19203		BOX, PACKING, AMMUNITION: for SABOT 60MM Practice, M3 and SABOT 81MM Practice, M1
GD-030-101617	UK		BOX, PACKING, AMMUNITION: Metal for Cartridge, 81MM, M821 and M889
12944511	19200		BOX, PACKING, AMMUNITION: PA157 Metal for Cartridge, 81MM, M853A1, M819, M816
12993639	19200		BOX, PACKING, AMMUNITION: PA156 Metal for Cartridge, 81MM, M821A1, M821A2, M889A1, M889A2
12630601	19203		CONTAINER, AMMUNITION: for Cartridge, 81MM M879
7548994	19203		CONTAINER ASSEMBLY: M37A5 for Cartridge, 81MM, M57 Series
8858643	19203		CONTAINER, AMMUNITION: M36A5 for Cartridge, 81MM, HE, M43 Series and TP, M43A1
9230175	19203		CONTAINER, AMMUNITION: M252A5 for Cartridge, 81MM, M362 Series, M374 Series, M375 Series
9241848	19203		CONTAINER, AMMUNITION: PA43 for Cartridge, 81MM, M601 Series, M301A3
GD-030-200777	UK		CONTAINER, AMMUNITION: Monpack for Cartridge, 81MM, M821 and M889
129943642	19200		CONTAINER, AMMUNITION: PA163 Fiber for Cartridge, 81MM, M821A1, M821A2, M889A1, M889A2

Section II. PACKING MATERIALS - Continued.

PART NO./ DWG. NO.	CAGE CODE	FIGURE NO.	DESCRIPTION
			81MM (Cont.)
12993640	19200		CONTAINER, AMMUNITION: PA162 Fiber for Cartridge, 81MM, M853A1, M819, M816
			120MM
512-5015-00	28260		BOX, PACKING, AMMUNITION: for Cartridge, 120MM, M57, M68, and M91
512-3007-01	28260		CONTAINER, AMMUNITION: for Cartridge, 120MM, M57, M68, and M91
12957067	19200		PACKING AND MARKING for Tube Assembly for 120MM, FRPC M931
12957063	19200		PACKING AND MARKING for Wirebound Box from 120MM, M931 FRPC
12957055	19200		WIREBOUND BOX
12957051	19200		PACKING TUBE ASSEMBLY
12577509	19200	4-1	CONTAINER, AMMUNITION: PA153 Fiber for Cartridge, 120MM Mortar, XM929, M929, M930, M933, M933A1, M934, M934A1, and M983.
12577569	19200		CONTAINER, AMMUNITION: PA154 Metal for 120MM Mortar Cartridge.
12577551	19200		PACKING AND MARKING FOR CONTAINER: PA 153 or PA167 Fiber for 120MM Mortar Cartridge family
12577570	19200		PACKING AND MARKING FOR CONTAINER: PA154 Metal for 120MM Mortar Cartridge family.
12995106	19200		CONTAINER, AMMUNITION: PA167, Fiber, Polylam. SEPARATE-LOADING AMMUNITION PROJECTILE ASSEMBLY 155MM AND 8-INCH
76-3-9	19203		DUMMY PROJECTILE, 8-INCH: M14, Wood crate.
9369660	19203		COVER, SUPPORT, RUBBER for LIFTING PLUG: for Projectile, 155MM Practice, M804A1.
8860552	19203		GASKET, RUBBER: for Lifting Plug Type, w/Fusible Insert, 1.84 in. ID-2.19 OD used on 155MM, M483A1; AT, M741; AT, M718: M692: M731 and War-head 105MM, HE XM548E1.
75-14-38-1H	19203		GASKET, SHELL: or Projectiles, 155MM, M116, M1, and M1A1. Height 13 in., Dia 2.38 in.
10520044	19203		GROMMET, ROTATING BAND: for Projectile 155MM, Models M101 Series, M104 Series, M470, M449E2, M112 Series, M112, XM402E2, and M485A2.
12912918	19200		SUPPORT BASE: for Projectile, 155MM, M825A1.
9378246	19203		FILLER, PACKING, PREFORMED: Used with P/N 9345325, Plug Lifting Assembly.
8857344-2	19203		PALLET: for Projectile, 175MM, M437 Series.
76-18-28-1	19203		PALLET: for Projectile, 155 MM, M118 Series.
9327882	19203		PALLET, FRAME, BOTTOM: for Projectile, 155MM, M549/M549A1.
9331806	19200		PALLET, BASE ASSEMBLY: for Projectile, 155MM, M804.

PART NO./ DWG. NO.	CAGE CODE	FIGURE NO.	DESCRIPTION
			155MM AND 8-INCH (Cont.)
9341620	19200		PALLET, BASE ASSEMBLY: for Projectile, 8-Inch, XM844.
9362570	19203		PALLET, BASE ASSEMBLY: for Projectile, 155MM, Practice, M804A1, M107.
7549275-4	19203		PALLET: for Projectiles 155MM, M107, M110 Series, M116 Series, M121 Series, M485 Series.
76-18-16-2	19203		PALLET: for Projectile, 8-Inch, M106, M404, M426.
9341619	19200		PALLET, COVER ASSEMBLY: for Projectile, 8-Inch, XM844.
9362571	19203		PALLET, COVER, ASSEMBLY: for Projectile, 155MM, M107 Practice, M804A1
7549275-3	19203		PALLET, PROJECTILE: for Projectile, 155MM, M107, M110 Series, M116 Series, M121 Series, M485 Series
76-18-16-1	19203		PALLET, PROJECTILE: for Projectile, 8-Inch, M106, M404, M426
8837839	19203		PALLET, PROJECTILE: for Projectiles, 155MM, M549A1, M483A1, M692, M718, M718A1, M731, M741, M471A1, M825, M825A1, M864, and M470
12914619	19203		PALLET, METAL, PROJECTILE: for Projectile, 155MM, HE, M898 (SADARM)
9229038	19203		PALLET, PROJECTILE: for Projectile, 8-Inch, M509A1
			PROPELLING SYSTEM
8796678	19203		BOX, PACKING, AMMUNITION: Fiberboard for Primer, Percussion, M82 or M75
9212310	19203		BOX, PACKING, AMMUNITION: Fiberboard, for XM5 flash reducer, for M86A1 propelling charge for 175MM Gun
8796679	19203		BOX, PACKING, AMMUNITION: for Primer, Percussion, M82, M75, or M119
8860559	19203		BOX, PACKING, AMMUNITION: for Primer. Percussion, MK24A, XM573
9211780	19203		BOX, PACKING, AMMUNITION: for Additive, Jacket, M1 for 175MM Gun, M113
9211781	19203		BOX, PACKING AMMUNITION: for Additive Jacket, M1 for 175MM Gun, M113
9226295	19203		BOX, PACKING, AMMUNITION: used with XM515 fuze containers for reducer, flash M2 for 155MM, M1
9295043	19203		BOX, WIREBOUND: for Spacer, Propelling Charge
9212311	19203		BOX, PACKING, AMMUNITION: for XM5 Flash, Reducer for M86A1 Propelling Charge for 175MM Gun
76-4-56-A	19203		BOX, PACKING, ASSEMBLY: M17, for Reducer, Flash, Propelling Charge, M3
9275845	19203		CONTAINER, AMMUNITION: Known as Container, Metal prop charge
8880527	19203		CONTAINER, AMMUNITION: M13A2 for Charge, Propelling, M4 Series

PART NO./ DWG. NO.	CAGE CODE	FIGURE NO.	DESCRIPTION
PROPELLING SYSTEM (Cont.)			
8880528	19203		CONTAINER, AMMUNITION: M14A2 for Charge, Propelling, 155MM, M31 Series
8880530	19203		CONTAINER, AMMUNITION: M18A2 for Charge, Propelling, 8-Inch, M1
8880531	19203		CONTAINER, AMMUNITION: M19A2 for Charges, Propelling, 8-Inch, M2 and M4
9234357	19203		CONTAINER, AMMUNITION: PA37A1 for Charge, Propelling, 155MM, M119, M119A1, M119A2
9226294	19203		SHIPPING, STORAGE CONTAINER, FUZE XM515: for Reducer, Flash, Propelling Charge, M2
9278205	19203		CONTAINER, AMMUNITION: PA68A1 metal for Charge, Propelling, 155MM, M203
9349398	19200		CONTAINER, AMMUNITION: PA103 metal for Charge, Propelling, 155MM, M203A1
9217658	19203		SHIPPING AND STORAGE CONTAINER, AMMUNITION: for Fuze M753 and Primer MK2A4; Primer, Percussion, MK2A42
12972583	19200		CONTAINER, AMMUNITION, METAL: PA161 for Charge, Propelling, 155MM, M231 (MACS)
12961080	19200		CONTAINER, AMMUNITION, METAL: PA103E2 for Charge, Propelling, 155MM, M232/M232A1 (MACS)

SECTION III. SPECIAL PACKING TOOLS LIST

PART NO./ DWG NO.	CAGE CODE	FIGURE NO.	DESCRIPTION
9287465	19203		CONTAINER: SHIPPING AND STORAGE (FOR GAGES)
APE 1263	19203		FIXTURE, TORQUING: FUZE BOOSTER (USED AS FUZE TO TORQUE WRENCH ADAPTER)
7304555	19203		GAGE, RING, PLAIN: ROCKWELL C63 TO C66, 4.1328 ± 0.0006 DIA, 0.125 CHAMFER ENDS, 15 DEGREE ANGLE, FOR PROJECTILE, 105MM, M1, M67, M60, M1 SERIES M444
7256913	19203		GAGE, RING, PLAIN: ROCKWELL C63 TO C66, 7.9980 ± 0.0005 DIA, 0.125 CHAMFER BOTH ENDS, 15 DEGREE ANGLE, DESIGNED FOR USE ON 8-INCH HE SHELL, M106, MK1A1
8816137	19203		GAGE, RING, PLAIN: TOOL STEEL, ROCKWELL C63 TO C66, 6.8890 ± 0.0006 DIA, 0.125 CHAMFER BOTH ENDS, 15 DEGREE ANGLE, DESIGNED FOR PROJECTILE 175MM, M437 SERIES
7257860	19203		GAGE, RING, PLAIN: TOOL STEEL, ROCKWELL C63 TO C66, 3.5400 ± 0.0005 DIA, 0.047 CHAMFER BOTH ENDS, 15 DEGREE ANGLE, DESIGNED FOR USE ON 90MM SHELL, SMOKE, WP, M313, HEAT T108E15
7304558	19203		GAGE, RING, PLAIN: TOOL STEEL, ROCKWELL C63 TO C66, 6.0984 ± 0.0005 DIA, 0.125 CHAMFER BOTH ENDS, 15 DEGREE ANGLES, FOR USE ON 155MM SHELL
8802210	19203		GO PLAIN RING GAGE: TOOL STEEL, ROCKWELL C63 TO C66, 7.8924 ± 0.0006 DIA, 0.125 CHAMFER BOTH ENDS, 15 DEGREE ANGLE, DESIGNED FOR USE ON 8-INCH SHELL, M103, M426, M106
9201580	19203		GO PLAIN RING GAGE: TOOL STEEL, ROCKWELL C63 TO C66, 5.9950 ± 0.0008 DIA, 0.125 CHAMFER BOTH ENDS, 15 DEGREE ANGLE, DESIGNED FOR USE ON CARTRIDGE 152MM, M625A1, XM617, M411 SERIES, M409A1
70016	70276		KEY: SOCKET HEAD SCREW, 1/2 IN. HEX, SGL END, L HANDLE
53M34750	11722		MARKING OUTFIT: RUBBER SOLID GOTHIC TYPE, 1/4, 1/2, 3/4, 1-INCH LETTERS
8195590	18876		PLIERS, SLIP-JOINT: A79 ANGLE NOSE, MULTIPLE TONGUE AND GROVE, STYLE A, CLASS I, TYPE II
GGG-M125	81348		RESPIRATOR, AIR FILTERING: PAINT SPRAY, M6
8864731	19203		SALEE CLOSER:
A-A-1399	58536		SOCKET, SOCKET WRENCH: SQ DRIVE, 1/2 IN. DRIVE SIZE, 12 PT OPENING 1-1/4 IN., TYPE II, CLASS II, STYLE A
520	00266		STRAPPING AND SEALING KIT: 5/8 INCH STRAPPING
1035	00266		STRAPPING AND SEALING KIT: 1-1/4 INCH STRAPPING
7231161	19206		WRENCH, FUZE-SETTER, COMBINATION: M18
F600I	26848		WRENCH, TORQUE: DEFLECTING FRAME END DRIVE STYLE, W/VISUAL PL INDICATING TORQUE MECH, 1/2 IN. MALE SQ-DRIVE, 600 INCH-LB CAPACITY, TYPE I, CLASS I, STYLE A

THIS PAGE INTENTIONALLY LEFT BLANK

APPENDIX C

DIRECT SUPPORT AND GENERAL SUPPORT MAINTENANCE

REPAIR PARTS AND SPECIAL TOOLS LIST

Section I. INTRODUCTION

C-1. Scope.

This RPSTL lists and authorizes spares and repair parts; special tools; special test, measurement, and diagnostic equipment (TMDE); and other special support equipment required for performance of direct support and general support (DS/GS) maintenance of Artillery Ammunition. It authorizes the requisitioning, issue, and disposition of spares, repair parts and special tools as indicated by the source, maintenance and recoverability (SMR) codes.

C-2. General.

In addition to Section I, Introduction, this Repair Parts and Special Tools List is divided into the following sections:

a. Section II - Repair Parts List. A list of spares and repair parts authorized by this RPSTL for use in the performance of maintenance. The list also includes parts which must be removed for replacement of the authorized parts, Parts lists are composed of functional groups in ascending alphanumeric sequence, with the parts in each group listed in ascending figure and item number sequence. Bulk materials are listed by item name in FIG BULK at the end of the section. Repair parts for repairable special tools are also listed in this section. Items listed are shown on the associated illustrations.

b. Section III- Special Tools List. Not applicable.

c. Section IV - Cross-reference Indexes. A list, in National item identification number (NIIN) sequence, of all National stock numbered items appearing in the listings, followed by a separate list in alphanumeric sequence of all part numbers appearing in the list. National stock numbers and part numbers are cross-referenced to each illustration figure and item number appearance. The figure and item number index lists figure and item number in alphanumeric sequence and cross-references NSN, CAGEC and part number.

C-3. Explanation of Columns (Sections II).

a. ITEM NO. (Column (1)). Indicates the number used to identify items called out in the illustration.

b. SMR CODE (Column (2)). The Source, Maintenance, and Recoverability (SMR) code is a 5-position code containing supply/requisitioning information, maintenance level authorization criteria, and disposition instructions, as shown in the following breakout:

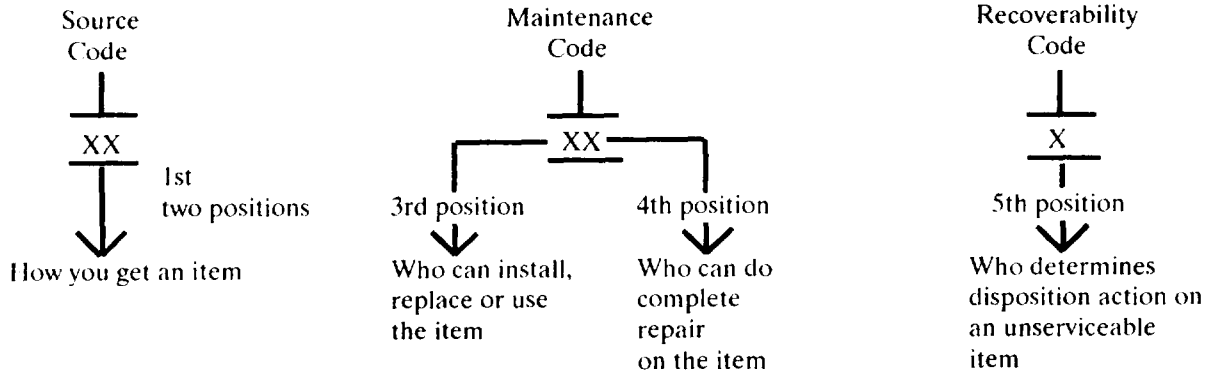

*Complete Repair: Maintenance capacity, capability, and authority to perform all corrective maintenance tasks of the "Repair" function in a use/user environment in order to restore serviceability to a failed item.

(1) Source Code. The source code tells you how you get an item needed for maintenance, repair, or overhaul of an end item/equipment. Source codes are always the first two positions of the SMR code. Explanations of source codes follow:

Code	Explanation
PA PB PC** PD PE PF PG	Stocked items; use the applicable NSN to request/requisition items with these source codes. They are authorized to the level indicated by the code entered in the 3rd position of the SMR code. ** NOTE: items coded PC are subject to deterioration.
KD KF KB	Items with these codes are not to be requested/requisitioned individually. They are part of a kit which is authorized to the maintenance level indicated in the 3rd position of the SMR code. The complete kit must be requisitioned and applied.
MO-(Made at unit Level) MF-(Made at DS Level) MH-(Made at GS Level) ML- (Made at Specialized Repair Act) (SRA) MD- (Made at Depot)	items with these codes are not to be requested/requisitioned individually. They must be made from bulk material which is identified by the part number in the DESCRIPTION AND USABLE ON CODE (UOC) column and listed in the Bulk Material group of the repair parts list in this RPSTL. If the item is authorized to you by the 3rd position code of the SMR code, but the source code indicates it is made at a higher level, order the item from the higher level of maintenance.

Code	Explanation
AO-(Assembled by unit Level)	Items with these codes are not to be requested/requisitioned individually. The parts that make up the assembled item must be requisitioned or fabricated and assembled at the level of maintenance indicated by the source code. If the 3rd position code of the SMR code authorizes you to replace the item, but the source code indicates the item is assembled at a higher level, order the item from the higher level of maintenance.
AF-(Assembled by DS Level)	
AH-(Assembled by GS Level)	
AL-(Assembled by SRA)	
AD-(Assembled by Depot)	

XA - Do not requisition an "XA" -coded item. Order its next higher assembly. (Also, refer to the NOTE below.)

XB - If an "XB" item is not available from salvage, order it using the CAGEC and part number.

XC - Installation drawing, diagram, instruction sheet, field service drawing; identified by manufacturer's part number.

XD - Item is not stocked. Order an "XD" -coded item through normal supply channels using the CAGEC and part number given, if no NSN is available.

NOTE

Cannibalization or controlled exchange, when authorized, may be used as a source of supply for items with the above source codes, except for those source coded "XA" or those aircraft support items restricted by requirements of AR 700-42.

(2) Maintenance Code. Maintenance codes tell you the level(s) of maintenance authorized to USE and REPAIR support items. The maintenance codes are entered in the third and fourth positions of the SMR Code as follows:

(a) The maintenance code entered in the third position tells you the lowest maintenance level authorized to remove, replace, and use an item, The maintenance code entered in the third position will indicate authorization to one of the following levels of maintenance.

Code	Application/Explanation
C	- Crew or operator maintenance done within unit maintenance.
O	- Unit level maintenance can remove, replace, and use the item.
F	- Direct support level maintenance can remove, replace, and use the item.
H	- General support level maintenance can remove, replace, and use the item.
L	- Specialized repair activity can remove, replace and use the item.
D	- Depot support level maintenance can remove, replace, and use the item.

(b) The maintenance code entered in the fourth position tells you whether or not the item is to be repaired and identifies the lowest maintenance level with the capability to do complete repair (i.e., perform all authorized repair functions).

NOTE

Some limited repair may be done on the item at a lower level of maintenance, if authorized by the Maintenance Allocation Chart (MAC) and SMR Codes.

Code	Application/Explanation
O	- Unit level is the lowest level that can do complete repair of the item.
F	- Direct support is the lowest level that can do complete repair of the item.
H	- General support is the lowest level that can do complete repair of the item.
L	- Specialized repair activity (designate the specialized repair activity) is the lowest level that can do complete repair of the item.
D	- Depot is the lowest level that can do complete repair of the item.
Z	- Nonrepairable. No repair is authorized.
B	- No repair is authorized. No parts or special tools are authorized for the maintenance of a "B" coded item. However, the item may be reconditioned by adjusting, lubricating, etc., at the user level.

(3) Recoverability Code. Recoverability codes are assigned to items to indicate the disposition action on unserviceable items. The recoverability code is shown in the fifth position of the SMR Codes as follows:

Recoverability codes	Application/Explanation
Z	- Nonrepairable item. When unserviceable, condemn and dispose of the item at the level of maintenance shown in 3rd position of SMR Code.
O	- Repairable item. When uneconomically repairable, condemn and dispose of the item at unit level.
F	- Repairable item. When uneconomically repairable, condemn and dispose of the item at direct support level.
H	- Repairable item, When uneconomically repairable, condemn and dispose of the item at the general support level.
D	- Repairable item. When beyond lower level repair capability, return to depot. Condemnation and disposal of item not authorized below depot level.
L	- Repairable item. Condemnation and disposal are not authorized below specialized repair activity (SRA).

A - Item requires handling of condemnation procedures because of specific reasons (e. g., precious metal content, high dollar value, critical material, or hazardous material). Refer to appropriate manuals/directives for specific instructions.

c. CAGEC (Column (3)). The commercial and Government Entity Code (CAGEC) is a 5-digit numeric code used to identify the manufacturer, distributor, or Government agency, etc., that supplies the item.

d. Part Number (Column (4)). indicates the primary number used by the manufacturer (individual company, firm, corporation, or Government activity), which controls the design and characteristics of the item by means of its engineering drawings, specifications, standards, and inspection requirements to identify an item or range of items. "

NOTE

When you use a NSN to requisition an item, the item you receive may have a different part number from the part ordered.

e. Description and Usable On Code (UOC) (Column (5)). This column includes the following information:

(1) The Federal item name, and when required, a minimum description to identify the item.

(2) Items that are included in kits and sets are listed below the name of the kit or set.

(3) Spare/repair parts that make up an assembled item are listed immediately following the assembled item line entry.

(4) Part numbers for bulk materials are referenced in this column in the line item entry for the item to be manufactured/fabricated.

(5) The statement "END OF FIGURE" appears just below the last item description in Column (5) for a given figure in Section II.

f. QTY (Column 6). The QTY (quantity per figure column) indicates the quantity of the item used in the breakout shown on the illustration/figure, "V appearing in this column in lieu of a quantity indicates that the quantity is variable and the quantity may vary from application to application.

C-4. Explanation of Columns (Section IV).

a. NATIONAL STOCK NUMBER (NSN) INDEX.

(1) STOCK NUMBER column. This column lists the NSN by National item identification number (NIIN) sequence. The NIIN consists of the last 9 digits of the NSN.

NSN
(i.e., 5305 -01-674-1467)
NIIN

When using this column to locate an item, ignore the first 4 digits of the NSN. However, the complete NSN should be used when ordering items by stock number.

(2) FIG. column. This column lists the number of the figure where the item is identified/located. The figures are in numerical order in Section II.

(3) ITEM column. The item number identifies the item associated with the figure listed in the adjacent FIG. column. This item is also identified by the NSN listed on the same line.

b. **PART NUMBER INDEX.** Part numbers in this index are listed by part number in ascending alphanumeric sequence (vertical arrangement of letters and number combinations which place the first letter or digit of each group in order A through Z, followed by the numbers 0 through 9 and each following letter or digit in like order).

(1) **CAGEC column.** The Commercial and Government Entity Code (CAGEC) is a 5-digit numeric code used to identify the manufacturer, distributor, or Government agency, etc., that supplies the item.

(2) **PART NUMBER column.** Indicates the primary number used by the manufacturer (individual, firm corporation, or Government activity) which controls the design and characteristics of the item by means of its engineering drawings, specifications, standards, and inspection requirements to identify an item or range of items.

(3) **STOCK NUMBER column.** This column lists the NSN for the associated part number and manufacturer identified in the PART NUMBER and CAGEC columns to the left.

(4) **FIG. column.** This column lists the number of the figure where the item is identified/located in Section II)

(5) **ITEM column.** The item number is that number assigned to the item as it appears in the figure referenced in the adjacent figure number column.

c. **FIGURE AND ITEM NUMBER INDEX.** This index lists the figures in the order in which they appear in Section II.

(1) **FIG. column.** This column lists the number of the figure where the item is identified/located in Section II)

(2) **ITEM column.** The item number is that number assigned to the item as it appears in the figure referenced in the adjacent figure number column.

(3) **STOCK NUMBER column.** This column lists the NSN for the item.

(4) **CAGEC column.** The Commercial and Government Entity Code (CAGEC) is a 5-digit numeric code used to identify the manufacturer, distributor, or Government agency, etc., that supplies the item.

(5) **PART NUMBER column.** Indicates the primary number used by the manufacturer (individual, firm corporation, or Government activity), which controls the design and characteristics of the item by means of its engineering drawings, specifications, standards, and inspection requirements to identify an item or range of items.

C-5 Special Information.

a. **ASSEMBLY INSTRUCTION.** Detailed assembly instructions for items source coded to be assembled from component spare/repair parts are found in the narrative portion of this manual. Items that make up the assembly are listed immediately following the assembly item entry or reference is made to an applicable figure.

b. **KITS.** Line item entries for repair parts kits appear in a group in Section II (see Table of Contents).

C-6. How to Locate Repair Parts.**a. When National Stock Number or Part Number is Not Known:**

(1) First. Using the table of contents, determine the assembly group or subassembly group to which the item belongs. This is necessary since figures are prepared for assembly groups and subassembly groups, and listings are divided into the same groups.

(2) Second. Find the figure covering the assembly group or subassembly group to which the item belongs.

(3) Third. Identify the item on the figure and note the number(s).

(4) Fourth. Refer to the repair parts list for the figure to find the part number(s) noted on the figure.

(5) Fifth. Refer to the figure and item number index to find the NSN, if assigned.

b. When National Stock Number or Part Number is Known:

(1) First. Using the National Stock Number or the Part Number Index, find the pertinent National Stock Number or Part Number. The NSN index is in National Item identification Number (NIIN) sequence (See C-4.a(1)). The part numbers in the Part Number index are listed in ascending alphanumeric sequence (See C-4.b). Both indexes cross-reference you to the illustration/figure and item number of the item you are looking for.

(2) Second. Turn to the figure and item number, verify that the item is the one you are looking for, and locate the item number in the repair parts list.

C-7. Abbreviations.

All are common.

Section II.

REPAIR PARTS

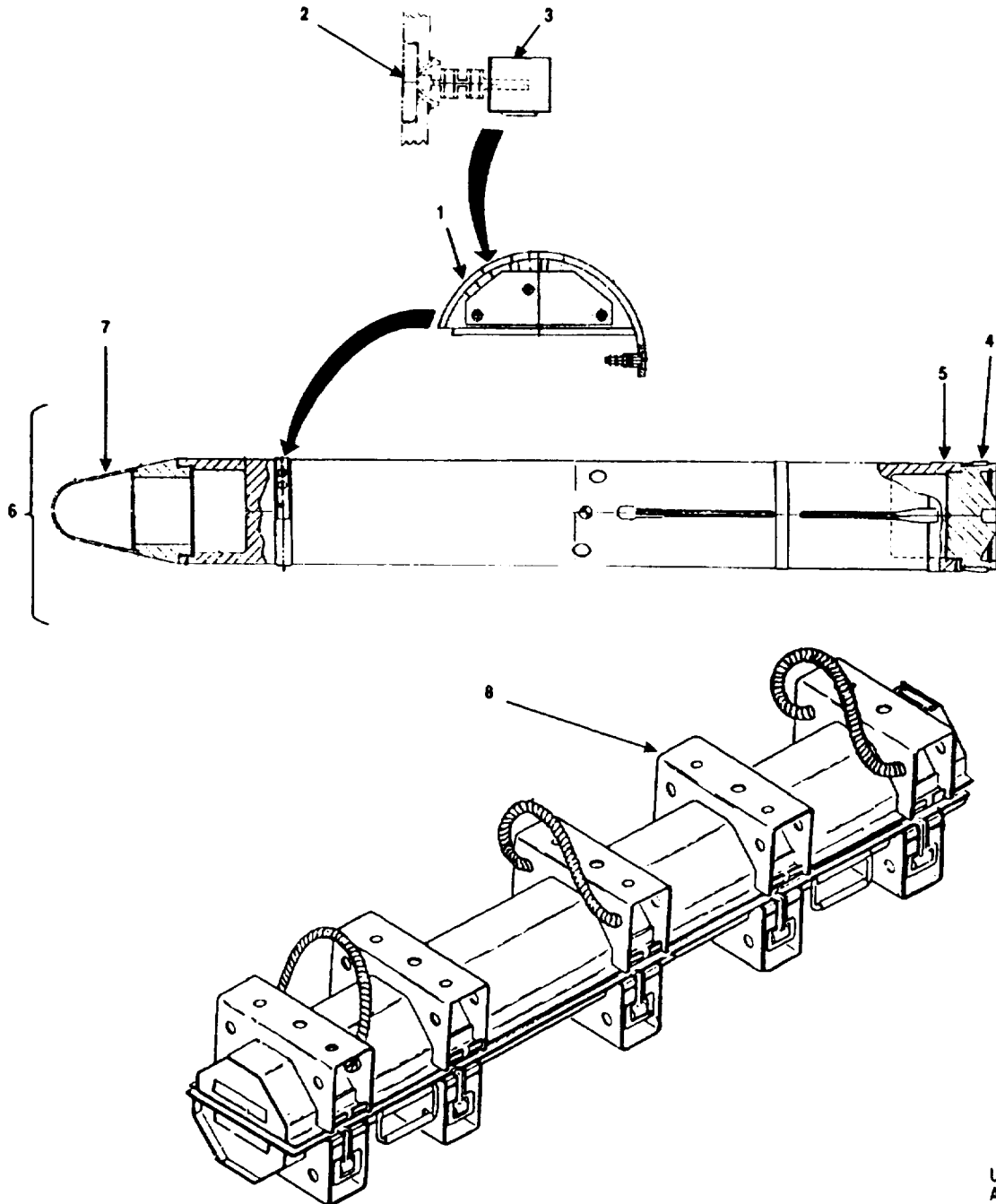

U
AR6303

FIGURE C1. PROJECTILE, 155MM:

(1) ITEM NO	(2) SMR CODE	(3) CAGEC	(4) PART NUMBER	(5) DESCRIPTION AND USABLE ON CODES (UOC)	(6) QTY
GROUP 00 PROJECTILE, 155MM 9329721 (19200) CHA					
FIGURE C1 PROJECTILE, 155 MM:					
1	PAOZZ	19200	9331768	SWITCH ASSEMBLY: ROTARY TYPE, MOUNTED PERPENDICULAR TO PROJECTILE BODY CIRCUMFERENCE	1
2	XAOZZ	19200	9332453	KNOB, ROTARY	1
3	XAOZZ	19200	9332454	SWITCH, ROTARY:	1
4	PAOZZ	19200	9331769	BASE, PROJECTILE: STL, ASTM A108 OR A576, 5.980 IN. OA DIA	1
5	PAOZZ	19200	9332456	OBTURATOR, PROJECTILE: 6.300 IN. DIA, 1.424 IN. L, NYLON PLASTIC MOLDING AND EXTRUSION	1
6	XBODD	19200	9331967	TRAINER ASSEMBLY: FOR PROJECTILE, TRAINING, M823 COPPERH UOC: EAD	1
7	PAOZZ	19200	9332455	OGIVE, PROJECTILE: PLASTIC, 5.09 IN. NOM OA L, 4.918 IN. NOM OA DIA	1
8	PAODD	19200	9300440	CONTAINER, AMMUNITION:	1
END OF FIGURE					

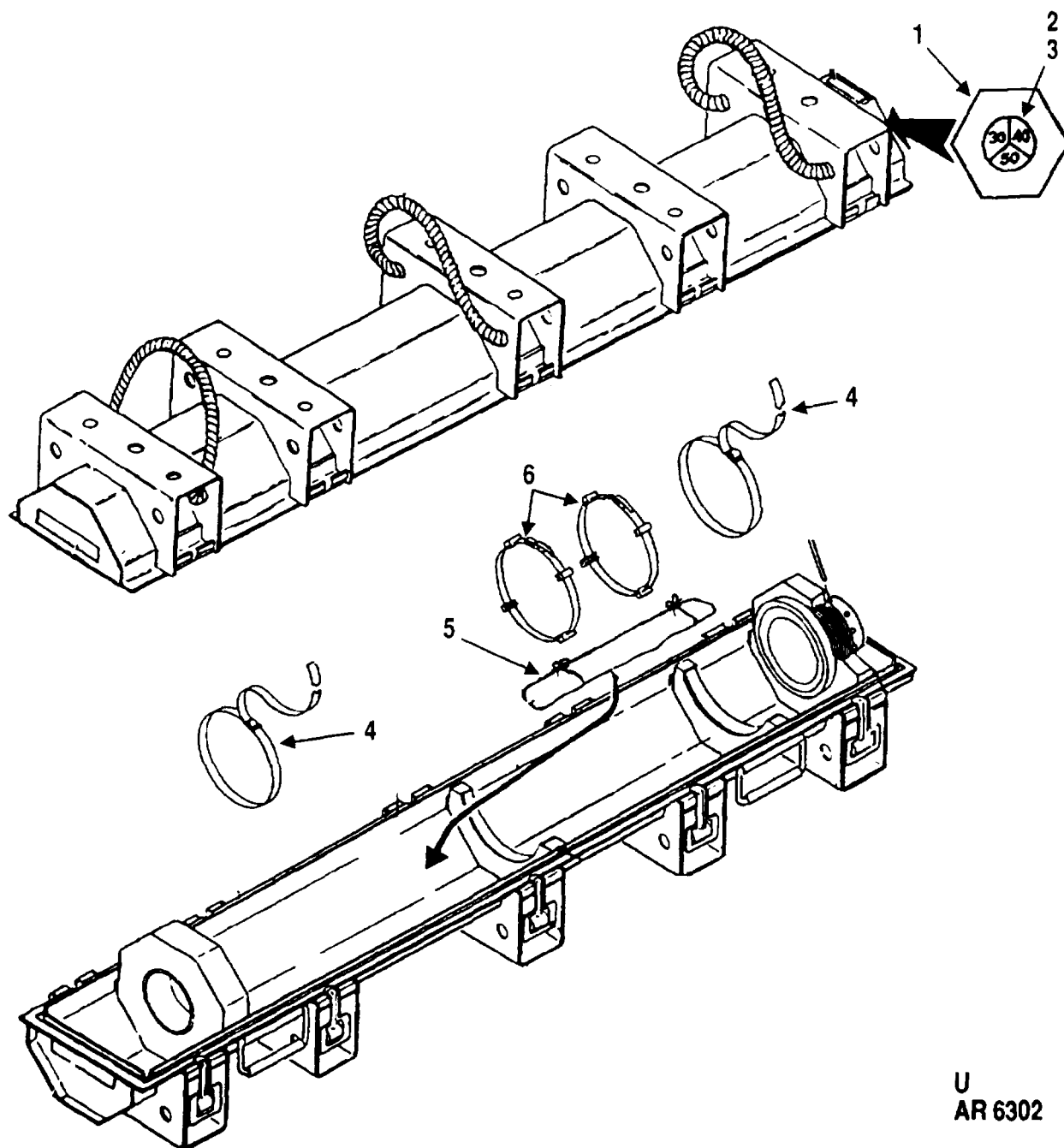

U
AR 6302

FIGURE C2. CONTAINER, AMMUNITION:

(1) ITEM NO	(2) SMR CODE	(3) CAGEC	(4) PART NUMBER	(5) DESCRIPTION AND USABLE ON CODES (UOC)	(6) QTY
GROUP 01 CONTAINER, AMMUNITION 93004400 (19200) CHC					
FIGURE C2 CONTAINER, AMMUNITION:					
1	PAOZZ	19200	9301821	INDICATOR, HUMIDITY, PLUG:	1
2	PAOZZ	19200	9349696	INDICATOR, HUMIDITY, CARD: CIRCULAR, 0.810 IN NOM OA DIA, 30PCT, 40 PCT, 50 PCT MARKINGS	1
3	PAOZZ	19200	9300445	INDICATOR, HUMIDITY, CARD: A1 RECTANGULAR, 0.790 IN. NOM OA L, 0.020 IN. NA OM W, 30 PCT, 40 PCT, 50 PCT MARKINGS	1
4	PAOZZ	19200	9301825	STRAP, WEBBING: NYLON, 56.75 IN. NOM L, 1.0 IN. NOM W, SLIDE LOOP ATTACHMENT	2
5	PAOZZ	19200	9300446	BAG ASSEMBLY, STORAGE:	1
6	PAOZZ	19200	9301827	CLAMP, LOOP:	2
END OF FIGURE					

Section III.
SPECIAL TOOLS LISTING

NOT APPLICABLE

CROSS-REFERENCE INDEXES

NATIONAL STOCK NUMBER INDEX

STOCK NUMBER	FIG	ITEM	STOCK NUMBER	FIG	ITEM
6685-00-243-6628	C2	3	1320-01-110-4848	C1	5
6685-01-038-6868	C2	1	8140-01-111-3906	C1	8
1320-01-095-0276	C1	1	8140-01-158-0517	C2	5
1320-01-095-9149	C1	4	6685-01-192-8759	C2	2
1320-01-108-0266	C1	7	5340-01-251-8682	C2	6
5340-01-110-3897	C2	4			

CROSS-REFERENCE INDEXES TM9-1300-251-34&P

PART NUMBER INDEX				
CAGEC	PART NUMBER	STOCK NUMBER	FIG	ITEM
19200	9300440	8140-01-111-3906	C1	8
19200	9300445	6685-00-243-6628	C2	3
19200	9300446	8140-01-158-0517	C2	5
19200	9301821	6685-01-038-6868	C2	1
19200	9301825	5340-01-110-3897	C2	4
19200	9301827	5340-01-251-8682	C2	6
19200	9331768	1320-01-095-0276	C1	1
19200	9331769	1320-01-095-9149	C1	4
19200	9331967		C1	6
19200	9332453		C1	2
19200	9332454		C1	3
19200	9332455	1320-01-108-0266	C1	7
19200	9332456	1320-01-110-4848	C1	5
19200	9349696	6685-01-192-8759	C2	2

APPENDIX D

EXPENDABLE AND DURABLE ITEMS LIST

SECTION I. INTRODUCTION

D-1. Scope

This appendix lists expendable and durable items required for DS/GS maintenance for guns, howitzers, mortars, recoilless rifles, and 40mm grenade launchers. This listing is for informational purposes only and is not authority to requisition the listed items. These items are authorized to you by CTA 50-970, expendable items (except Medical, Class V, Repair Parts, and Heraldic Items).

D-2. Explanation of Columns

a. Column (1) - Item number. This number is assigned to the entry in the listing for referencing when required.

h. Column (2) - Level. This column identifies the lowest level of maintenance that requires the listed item.

- O - Unit Maintenance
- F - Direct Support Maintenance
- H - General Support Maintenance

c. Column (3) - National Stock Number. This is the national stock number assigned to the item; use it to request or requisition the item.

d. Column (4) - Description. Indicates the federal item name and, if required, a description to identify the item. The last line for each item indicates the Commercial and Government Entity Code (CAGEC) parentheses followed by the part number.

e. Column (5) - Unit of Measure (U/M)/Unit of Issue (U/I). This measure is expressed by a two-character alphabetical abbreviation (e.g., EA, IN, PR). If the unit of measure differs from the unit of issue as shown in the Army Master Data File (AMDF) requisition the lowest unit of issue that will satisfy your requirements.

SECTION II. EXPENDABLE AND DURABLE ITEMS LIST

(1)	(2)	(3)	(4)	(5)
ITEM NUMBER	LEVEL	NATIONAL STOCK NUMBER	DESCRIPTION	(U/M)/ (U/I) CN
1	O	6810-00-184-4796	ACETONE, TECHNICAL: 5 GAL CAN, LIQUID (81348) O-A-51	CN
2	O	6810-00-543-7415	ALCOHOL, DENATURED: GRADE III (81348) OE760	GL
3	O	8135-00-282-0565	BARRIER MATERIAL, WATERVAPOR PROOFED, FLEXIBLE: 200-YD ROLL, 36 IN. WIDE, CLASS I (81349) MILB131	RO
4	O	8020-00-240-6361	BRUSH, ARTISTS: FLAT, CHISEL EDGE, 1/8 IN. WIDE (81348) H-B-118	EA
5	O	8020-00-246-8504	BRUSH, ARTIST: ROUND, FLAT EDGE, 1/8 IN. WIDE (81348) H-B-118	EA
6	O	7920-00-900-3577	BRUSH: (FUZEWELL) 3/4 IN. X 1-3/8 IN. (17987) 15SS	EA
7	O	8020-00-597-4768	BRUSH, ARTIST'S: FLAT EDGE, 7/8 IN. X 1 IN. (81348) H-B-351	EA
8	O	8020-00-245-4522	BRUSH, PAINT: FLAT, SQUARE EDGE, 2-1/2 IN. W, 1-1/4 LG (81348) H-B-391	EA
9	O	8020-00-245-4516	BRUSH, PAINT: FLAT, SQUARE EDGE, 4 IN. WIDE X 4-1/8 IN. LG (81348) H-B-420	EA
10	O	8020-00-597-5301	BRUSH, PAINT: OVAL STYLE, CHISEL EDGE, 7/8 IN. X 2-1/8 IN. (81348) H-B-491	EA
11	O	7520-00-248-9285	BRUSH, STENCIL: FOUNTAIN STYLE, 1-3/8 IN. DIA, TYPE F (81348) H-B-00621	EA
12	O	7520-00-223-8000	BRUSH, STENCIL: LONG HANDLE STYLE, TYPE L, 0.813 DIA OF BRISTLES (81348) H-B-00621	EA
13	O	8020-00-889-7919	BRUSH, PAINT: 1-1/2 IN., FLAT, SQUARE EDGE (81348) H-B-420	EA

SECTION II. EXPENDABLE AND DURABLE ITEMS LIST - CONTINUED

(1)	(2)	(3)	(4)	(5)
ITEM NUMBER	LEVEL	NATIONAL STOCK NUMBER	DESCRIPTION	(U/M)/ (U/I)
14	O	8020-00-205-6505	BRUSH, PAINT: FLAT, CHISEL EDGE, 1-1/2 IN. W, 11/16 IN. THK, 2-1/4 IN. LG TYPE 1, GRADE A (81348) H-B-420	EA
15	O	8020-00-262-9084	BRUSH, VARNISH: FLAT, SQUARE EDGE, 1/2 IN. W, 1/4 IN. THK, 1-1/4 IN. LG (45092) 608-1	EA
16	O	7920-00-255-5135	BRUSH, WIRE SCRATCH: WOOD AND COPPER BERYLLIUM ALLOY, CURVED HANDLE, 14 IN. X 15/16 IN. BLOCK, 6 IN. X 1-1/4 IN. (81348) HBL78	EA
17	O	7920-00-269-0933	BRUSH, WIRE SCRATCH: WOOD AND COPPER BERYLLIUM ALLOY, STRAIGHT HANDLE, 7-IN. X 1 IN. BLOCK, 6 IN. X 1-1/4 IN. (81348) HBL78	EA
18	O	5999-00-501-8369	CLIP, ELECTRICAL: BATTERY CLIP (81348) WC440	EA
19	O	5350-00-192-5051	CLOTH, ABRASIVE: 180 GRIT, 9 IN. WIDE (81348) PC451	PG
20	O	5350-00-192-9316	CLOTH, ABRASIVE: 220 GRIT, 9 IN. WIDE (58536) A-A-1048	PG
21	O	5350-00-246-0330	CLOTH, ABRASIVE: 320 GRIT, 9 IN. WIDE (58536) A-A-1048	PG
22	O	8030-00-664-7105	COATING, COMPOUND, BITUMINOUS SOLVENT TYPE: TYPE I (81349) MIL-C-450	GL
23	O	8030-00-290-5141	COATING, COMPOUND, BITUMINOUS SOLVENT TYPE: TYPE II (81349) MIL-C-450	GL
24	O	8030-00-231-2345	CORROSION PREVENTATIVE COMPOUND: COLD APPLICATION TYPE, GRADE II (81349) MIL-C-16173	GL
25	O	6850-00-174-9672	CORROSION, REMOVING COMPOUND: LIQUID (81349) MILC10578	GL
26	O	6850-00-264-6573	DESSICANT, ACTIVATED: TYPE I, 5 GL CAN (81349) MIL-D-3464	CN

SECTION II. EXPENDABLE AND DURABLE ITEMS LIST - CONTINUED

(1)	(2)	(3)	(4)	(5)
ITEM NUMBER	LEVEL	NATIONAL STOCK NUMBER	DESCRIPTION	(U/M)/ (U/I)
27	O	6850-00-935-9794	DESSICANT, ACTIVATED: 8 UNIT BAG, 240 BAGS/DRUM, TYPE II (81349) MIL-D-3464	DR
28	O	7930-00-249-8036	DETERGENT, GENERAL PURPOSE: FLAKE OR POWDER (58536) A-A-1376	CO
29	O	8010-00-297-2122	ENAMEL: BLACK, NO.37038 (81348) TT-E-516	GL
30	O	8010-00-910-8154	ENAMEL: BLACK, NO. 37038 (81348) TT-E-516	PT
31	O	8010-00-297-2119	ENAMEL: BLUE, NO. 35109 (96906) MS 35527-3	GL
32	O	8010-00-598-5939	ENAMEL: GREEN, NO. 34108 (81348) TT-E-515	GL
33	O	8010-00-828-3193	ENAMEL: GREEN, NO. 34558 (81348) TT-E-516	GL
34	O	8010-00-067-5436	ENAMEL: CAN, AEROSOL, FULL GLOSS, CLEAR (81348) TT-E-00488	PT
35	O	8010-00-297-2116	ENAMEL: OLIVE DRAB, LUSTERLESS (81348) TT-E-516	GL
36	O	8010-00-848-9272	ENAMEL: OLIVE DRAB, LUSTERLESS, NO. 34088, SPRAY CAN (81348) TT-E-516	PT
37	O	8010-01-088-0096	ENAMEL: ORANGE, NO. 32246, SPARY CAN (81348) TT-E-515	GL
38	O	8010-00-297-0563	ENAMEL: ORANGE, NO. 35524-13 (96906) MS 35524-13	GL
39	O	8010-00-297-0809	ENAMEL: RED, NO. 31136 (81349) TT-E-515	PT
40	O	8010-00-087-0107	ENAMEL: WHITE, NO. 27875 (81349) TT-E-515	QT
41	O	8010-00-878-5761	ENAMEL: WHITE, NO. 37875, SPRAY CAN (81348) TT-E-516	PT

SECTION II. EXPENDABLE AND DURABLE ITEMS LIST - CONTINUED

(1)	(2)	(3)	(4)	(5)
ITEM NUMBER	LEVEL	NATIONAL STOCK NUMBER	DESCRIPTION	(U/M)/ (U/I)
42	O	8010-00-297-2111	ENAMEL: WHITE, NO. 37875 (81348) TT-E-516	GL
43	O	8010-00-297-2112	ENAMEL: YELLOW, NO. 33538 (96908) MS 35527-12	GL
44	O	8010-00-848-6424	ENAMEL: YELLOW, NO. 33538 (81348) TT-E-516	QT
45	O	8010-00-851-5525	ENAMEL: YELLOW, SEMI-GLOSS, NO. 33538 (09786) SW 101-43	PT
46	O	8010-00-598-5465	ENAMEL: BROWN, LUSTERLESS 1 GAL, NO. 30117 (81348) TT-E-527	CN
47	O	5315-00-597-9766	FASTENER, CORRUGATED, WOOD, JOINT: STEEL, 1/2 IN. SAWTOOTH (58536) A-A-1957	HD
48	O	8415-00-682-6786	GLOVES, DISPOSABLE: PLASTIC (96717) PINKIES	PR
49	O	9150-00-190-0904	GREASE, AUTOMOTIVE AND ARTILLERY: (81349) MIL-G-10924	CN
50	O	8520-00-782-3509	HAND CLEANER: CLASS 2 PASTE, GRADE A (10266) DD10	CN
51	O	7510-00-161-0811	INK, MARKING STENCIL: BLACK (58536) A-A-208	GL
52	O	7510-00-161-0813	INK, MARKING STENCIL: BLACK (58536) A-A-208	QT
53	O	7510-00-161-0815	INK, MARKING STENCIL: WHITE (58536) A-A-208	GL
54	O	7510-00-161-0816	INK, MARKING STENCIL: YELLOW (58536) A-A-208	GL
55	O	6810-00-753-4993	ISOPROPYL ALCOHOL, TECHNICAL: GRADE A (81348) TT-I-735	CN
56	O	8010-00-515-2487	LACQUER: CLEAR, SPRAY, 16 OZ (81348) TT-L-50	PT
57	O	8010-00-068-8779	LACQUER: FOREST GREEN, NO. 34079 (81349) MIL-L-81352	PT

SECTION II. EXPENDABLE AND DURABLE ITEMS LIST - CONTINUED

(1)	(2)	(3)	(4)	(5)
ITEM NUMBER	LEVEL	NATIONAL STOCK NUMBER	DESCRIPTION	(U/M)/ (U/I)
58	O	8010-00-721-9752	LACQUER: GOLD, NO. 17043, SPRAY, 16 OZ (81348) TT-L-50	PT
59	O	8010-00-584-3148	LACQUER: ORANGE, NO. 12179, SPRAY CAN (81348) TT-L-50	PT
60	O	9150-00-231-6689	LUBRICATING OIL, GENERAL PURPOSE (81348) VV-L-800	QT
61	O	7520-00-973-1059	MARKER, TUBE TYPE: BLACK (81348) GG-M-00114	DZ
62	O	7520-00-973-1062	MARKER, TUBE TYPE: RED (81348) GG-M-00114	DZ
63	O	7520-00-079-0288	MARKER, TUBE TYPE: YELLOW (81348) GG-M-00114	DZ
64	O	5315-00-889-2743	NAIL: STEEL HEAD STYLE 19, 1.5 IN. (81348) FF-N-105	PG
65	O	5315-00-889-2744	NAIL: STEEL 6D, 2 IN. (81348) FF-N-105	PG
66	O	5315-00-889-2745	NAIL: STEEL 8D, 2.5 IN. (81348) FF-N-105	PG
67	O	8010-00-598-5465	PAINT, OIL: (81348) TT-E-527	GL
68	O	8010-00-159-4513	PAINT, RUBBER: BLANK, NO. 27038 (81349) MIL-P-9503	GL
69	O	8010-00-285-4917	PAINT, STENCIL: BLACK, NO. 37038 (81348) TT-P-98	QT
70	O	8010-00-226-3906	PAINT, STENCIL: SAND, NO. 30277 (81349) MIL-P-52108	GL
71	O	8010-00-285-4933	PAINT, STENCIL: WHITE, NO. 37875 (81348) TT-P-98	GL
72	O	8010-00-285-4935	PAINT, STENCIL: YELLOW, NO. 33538 (81348) TT-P-98	QT
73	O	5350-00-271-7930	PAPER, ABRASIVE, FLINT: 120-150 GRIT (81348) P-P-105	PG

SECTION II. EXPENDABLE AND DURABLE ITEMS LIST - CONTINUED

(1)	(2)	(3)	(4)	(5)
ITEM NUMBER	LEVEL	NATIONAL STOCK NUMBER	DESCRIPTION	(U/M)/ (U/I)
74	O	8135-00-160-7757	PAPER, KRAFT, UNTREATED: CHEMICAL TREATMENT UNBLEACHED UU-P-268	RO
75	O	8010-00-515-2208	PRIMER COATING: ZINC YELLOW (81348) TT-P-1757	GL
76	O	7920-00-205-1711	RAG, WIPING: COTTON, UNBLEACHED, MIXED COLORS (81348) DDD-R-30	BE
77	O	5975-00-296-5324	ROD, GROUND: STEEL, COPPER-COVERED, 5/8 IN. DIA, 8-FT LG (81348) W-R-550	EA
78	O	5330-00-729-5103	RUBBER, SHEET, SOLID: 1/8 IN. THK, 36 W (81349) MIL-G-1149	EA
79	O	5340-00-491-7632	SEAL, ANTIPIILFERAGE, METALLIC: 0.5 IN. DIA, 1/8 IN THK (96906) MS 519385	EA
80	O	8135-00-239-5291	SEAL, STRAPPING: STEEL FOR 5/8 IN. WIDE STEEL STRAPPING, TYPE D, STYLE II, CLASS R, GR 2, FINISH B (81346) ASTM D 3953-87	BX
81	O	8135-00-239-5288	SEAL, STRAPPING: FOR 3/4 IN. WIDE STEEL STRAPPING, TYPE D, STYLE I, CLASS R, GR 2, FINISH B (81346) ASTM D 3953-87	BX
82	O	8135-00-239-5294	SEAL, STRAPPING: STEEL, FOR 1-1/4 IN. STEEL STRAPPING (81346) ASTM D 3953-87	BX
83	O	8030-00-245-7032	SEALING COMPOUND: TYPE A (81350) JAN-C-99	GL
84	O	5315-00-664-7035	STRAP: STEEL, TYPE 3, STYLE 4 (81348) FF-N-105	BX
85	O	9310-00-240-4737	STENCILBOARD: OILED, 18-1/2 IN. X 18-1/2 IN. (81348) UU-S-625	SH
86	O	8135-00-281-4071	STRAPPING: STEEL, 5-8 IN. WIDE, NAILLESS, REG DUTY, CLASS 1, TYPE 1 (81346) ASTM D 3953-87	CL
87	O	8135-00-281-4069	STRAPPING: STEEL, 3/4 IN. WIDE, NAILLESS, REG DUTY, CLASS 1, TYPE 1 (81346) ASTM D 3953-87	CL

SECTION II. EXPENDABLE AND DURABLE ITEMS LIST - CONTINUED

(1)	(2)	(3)	(4)	(5)
ITEM NUMBER	LEVEL	NATIONAL STOCK NUMBER	DESCRIPTION	(U/M)/ (U/I) CL
88	O	8135-00-283-0671	STRAPPING: STEEL, 1 1/4 IN. WIDE, NAILESS, HEAVY DUTY, TYPE 1, GR 2 (81346) ASTM D 3953-87	CL
89	O	4020-00-033-7695	TAPE, LACING AND TYING: PLASTIC, WHITE 250 YDS (81349) MIL-T-43435	SL
90	O	7510-00-266-6711	TAPE, PRESSURE SENSITIVE ADHESIVE: MASKING, TAN, ONE SIDE ADHESIVE, 3/4 IN. W, 60 YD ROLL (58536) A-A-883	RO
91	O	7510-00-266-6712	TAPE, PRESSURE SENSITIVE ADHESIVE: MASKING, 1 IN. W, 60 YD ROLL, OPAQUE (19203) 8783476	RO
92	O	7510-00-266-6710	TAPE, PRESSURE SENSITIVE ADHESIVE: MASKING, 2-IN. W, 60 YD ROLL, OPAQUE (19203) 802563	RO
93	O	7510-00-266-6715	TAPE, PRESSURE SENSITIVE ADHESIVE: 2-IN. W, CLEAR, 60 YD ROLL (52170) 351	RO
94	O	8010-00-242-2089	THINNER, PAINT, PRODUCTS: (81348) TT-T-291	GL
95	O	8010-00-160-5794	THINNER, PAINT, PRODUCTS: (81348) TT-T-306	GL
96	O	8010-00-221-2809	VARNISH, OIL: (96906) MS35636-1	QT
97	O	6415-00-990-2999	WIRE, ELECTRICAL: BLACK, SINGLE STRANDED (81348) J-C-30	FT
98	O	9505-00-294-7373	WIRE, NONELECTRICAL: ROUND, ZINC COATED, 0.0363 IN. DIA, SOFT TEMPER (81346) ASTM A641	CL

APPENDIX E

MARKING FOR CARTRIDGES and PROJECTILES

<u>Figure</u>	<u>Title</u>	<u>AR No.</u>
E-1	Typical Marking for 35MM TP-T Cartridge M968.	AR 3977
E-2	Typical Marking for 40MM Grenade Cartridges M381, M382, M386, M406, M407, and M441 Series.	AR 100024
E-3	Typical Marking for 40MM Grenade Cartridge M433.	AR 100025
E-4	Typical Marking for 40MM Grenade Cartridge M651.	AR 100026
E-5	Typical Marking for 40MM Grenade Cartridge M585.	AR 101632
E-6	Typical Marking for 40MM Grenade Cartridges M583A1, M661, M662, and M992.	AR 101633
E-7	Typical Marking for 40MM Grenade Cartridges M713, M715, and M716.	AR 101634
E-8	Typical Marking for 40MM Grenade Cartridge M576.	AR 101635
E-9	Typical Marking for 40MM Grenade Cartridges M674 and M675.	AR 100029
E-10	Typical Marking for 40MM Grenade Cartridges M383, M384, and M684.	AR 100030
E-11	Typical Marking for 40MM Grenade Cartridge M430.	AR 100031
E-12	Typical Marking for 40MM Grenade Cartridge M918.	AR 2665-A
E-13	Typical Marking for 40MM Grenade Cartridge M385.	AR 100032
E-14	Typical Marking for 40MM Grenade Cartridge M81A1.	AR 100033
E-15	Typical Marking for 40MM Grenade Cartridges MK2, M25, and M91.	AR 100034
E-16	Typical Marking for 60MM Mortar Cartridges M302 Series.	AR 100035
E-17	Typical Markings for 40MM Gun Cartridges M811, M813, M822, and M851 (SGT York).	ARD 84-1609
E-17.1	Typical Marking for 40MM Dummy Cartridge M922.	AR 6032
E-17.2	Typical Marking for 40MM Dummy Cartridge M922A1.	AR 6031
E-17.3	Typical Marking for 40MM Grenade Cartridge MK281 MOD 0.	AR 18176
E-17.4	Typical Marking for 40MM Grenade Cartridge M1001.	AR 18177
E-18	Typical Marking for 60MM Mortar Cartridges M83 Series.	AR 100036
E-19	Typical Marking for 60MM Mortar Cartridges M49 Series, M50 Series, and M720.	AR 100037
E-20	Typical Marking for 60MM Mortar Cartridge M721.	AR 4183
E-21	Typical Marking for 60MM Mortar Cartridge M722 and M722A1.	AR 4184
E-21.1	Typical Marking for 60MM Mortar Cartridges M720A1 and M768.	AR 10798
E-21.2	Typical Marking for 60MM Mortar Cartridge M769.	AR 10981
E-21.3	Typical Marking for 60MM Mortar Cartridge M1061.	AR 18178
E-22	Typical Marking for 81MM Mortar Cartridges M362 Series, M370, and M445.	AR 100038
E-23	Typical Marking for 81MM Mortar Cartridges M374 Series and M375 Series.	AR 100039
E-24	Typical Marking for 81MM Mortar Cartridge XM879.	AR 4185
E-25	Typical Marking for 81MM Mortar Cartridges M301 Series.	AR 100040
E-26	Typical Marking for 81MM Mortar Cartridges M57 Series.	AR 100041
E-27	Typical Marking for 81MM Mortar Cartridges M821 Series.	AR 4186
E-28	Typical Marking for 81MM Mortar Cartridges M889 Series.	AR 4187
E-29	Typical Marking for 81MM Mortar Cartridges M23 Series (HE and TP).	AR 100042
E-30	Typical Marking for 84MM Launcher Cartridges M136 (AT4) and AT4 CS RS.	AR 2805
E-31	Typical Marking for 90MM Gun Cartridge M580.	AR 100043
E-32	Typical Marking for 90MM Gun Cartridges M77, M318, and M353 Series.	AR 100044
E-33	Typical Marking for 90MM Gun Cartridge M332A1.	AR 100045
E-34	Typical Marking for 90MM Gun Cartridge M313 Series.	AR 100046
E-35	Typical Marking for 90MM Gun Cartridge M71 Series.	AR 100047

<u>Figure</u>	<u>Title</u>	<u>AR No.</u>
E-36	Typical Marking for 90MM Gun Cartridge M82.	AR 100048
E-37	Typical Marking for 90MM Gun Cartridges M348A1 Series.	AR 100049
E-38	Typical Marking for 90MM Gun Cartridges M431 Series.	AR 100050
E-39	Typical Marking for 90MM Gun Cartridges M336 and M377.	AR 100051
E-40	Typical Marking for Cartridge Case on 90MM Gun Cartridge M431A2.	AR 100052
E-41	Typical Marking for Cartridge Case on 90MM Rifle Cartridge M371A1.	AR 100053
E-42	Typical Marking for 90MM Rifle Cartridge M590.	AR 100054
E-43	Typical Marking for 90MM Rifle Cartridge M371 Series.	AR 100055
E-44	Typical Marking for 105MM Howitzer Cartridge M913.	AR 4511
E-44.1	Typical Marking for 105MM Howitzer Cartridge M927.	AR 5395
E-45	Typical Marking for Cartridge Case on 105MM Howitzer Round M1.	AR 100056
E-45.1	Typical Marking for 105MM Howitzer Cartridge M915.	AR 10910
E-46	Typical Marking for Projectile of 105MM Howitzer Cartridge XM629.	AR 100057
E-47	Typical Marking for Projectile of 105MM Howitzer Cartridge M546.	AR 100058
E-48	Typical Marking for Projectile of 105MM Howitzer Cartridge M327.	AR 100059
E-49	Typical Marking for Projectile of 105MM Howitzer Cartridge M60 Series and M84 Series.	AR 100061
E-50	Typical Marking for Projectile of 105MM Howitzer Cartridges M1, M67, M413, and M444.	AR 100062
E-51	Typical Marking for Projectile of 105MM Howitzer Cartridge M314 Series.	AR 100063
E-52	Typical Marking for Projectile of 105MM Howitzer Cartridge M548.	AR 100064
E-53	Typical Marking for 105MM Gun Cartridge, DM128.	ARD 2769
E-54	Typical Marking for 105MM Gun Cartridge XM494E3.	AR 100065
E-55	Typical Marking for 105MM Gun Cartridges M393 Series, M416, and M417.	AR 100066
E-55.1	Typical Marking for 105MM Gun Cartridge M1040.	AR 13033
E-55.2	Typical Marking for 105MM Gun Cartridge M393A3.	AR 12523
E-55.3	Typical Marking for 105MM Gun Cartridge M467A1.	AR 12541
E-56	Typical Marking for 105MM Gun Cartridges M392 Series and M724 Series.	AR 100067
E-57	Typical Marking for 105MM Gun Cartridges M735, M774, M833, and M900.	AR 4655
E-58	Typical Marking for 105MM Gun Cartridges M456 Series and M490 Series.	AR 100068
E-59	Typical Marking for Cartridge Case on 105MM Gun Cartridge M456 Series.	AR 100069
E-60	Typical Marking for 4.2-in. Mortar Cartridges M2, M630, and M328A1.	AR 100070
E-61	Typical Marking for 4.2-in. Mortar Cartridges M3 Series, M329 Series, and M335A2.	AR 100072
E-62	Typical Marking for Cartridge Case on 106MM Rifle Cartridge M581.	AR 100073
E-63	Typical Marking for 106MM Rifle Cartridge M346A1.	AR 100074
E-64	Typical Marking for 106MM Rifle Cartridge M344A1.	AR 100075
E-65	Typical Marking for 106MM Rifle Cartridge M581.	AR 100076
E-66	Typical Marking for 120MM Gun Cartridges M829, M829A1, and M865.	AR 5796
E-67	Typical Marking for 120MM Gun Cartridges M829A2 and M829A3.	AR 9369
E-67.1	Typical Marking for 120MM Gun Cartridge HE-OR-T, M908.	AR 10292
E-68	Typical Marking for 120MM Gun Cartridge M830.	AR 5799
E-69	Typical Marking for 120MM Gun Cartridges HEAT-MP-T, M830A1.	AR 4344-A
E-70	Typical Marking for 120MM Gun Cartridges M831 and M831A1.	AR 8143
E-71	Typical Marking for 120MM Mortar Cartridges M57 Series.	AR 4294
E-71.1	Typical Marking for 120MM Gun Cartridge TPMP-T, XM1002.	AR 11602
E-71.2	Typical Marking for 120MM Gun Cartridge Canister, M1028.	AR 11826
E-72	Typical Marking for 120MM Mortar Cartridges M68 Series.	AR 4295
E-73	Typical Marking for 120MM Mortar Cartridges M91 Series.	AR 4296
E-74	Typical Marking for 120MM Mortar Cartridge M933 and M933A1.	AR 18179
E-75	Typical Marking for 120MM Mortar Cartridge M934 and M934A1.	AR 10795
E-76	Typical Marking for 120MM Mortar Cartridge M930 and M983.	AR 10796

<u>Figure</u>	<u>Title</u>	<u>AR No.</u>
E-77	Typical Marking for 120MM Mortar Cartridge XM929 and M929.	AR 10797
E-78	Typical Marking for 120MM Mortar Cartridge M931.	AR 7770
E-79	Deleted.	
E-80	Typical Marking for 152MM Gun Cartridge M625.	AR 100079
E-81	Typical Marking for 155MM Howitzer Projectiles M107, M110 Series, and M116 Series.	AR 100080
E-82	Typical Marking for 155MM Howitzer Projectile M804.	AR 8936
E-82.1	Typical Marking for 155MM Howitzer Projectile M795.	AR 8141
E-83	Typical Marking for 155MM Howitzer Projectile M804A1.	AR 4656
E-84	Typical Marking for 155MM Howitzer Projectile M449A1.	AR 100081
E-85	Typical Marking for 155MM Howitzer Projectile M549.	AR 101577
E-86	Typical Marking for 155MM Howitzer Projectile M118 Series and M485 Series.	AR 100083
E-87	Typical Marking for 155MM Howitzer Projectile M483A1.	AR 101636-A
E-88	Typical Marking for 155MM Howitzer Projectile M687.	ARD 2773
E-89	Typical Marking for 155MM Howitzer Projectile M692.	AR 101637-A
E-90	Typical Marking for 155MM Howitzer Projectile M731.	AR 101638-A
E-91	Typical Marking for 155MM Howitzer Projectile M718.	ARD 80-0161
E-92	Typical Marking for 155MM Howitzer Projectile M741.	ARD 80-0162
E-93	Typical Marking for 155MM Howitzer Projectile M718A1.	ARD 2770
E-94	Typical Marking for 155MM Howitzer Projectile M741A1.	ARD 2771
E-95	Typical Marking for 155MM Howitzer Projectile M825.	ARD 2774
E-96	Typical Marking for 155MM Howitzer Projectile M825A1.	AR 4657
E-96.1	Typical Marking for 155MM Howitzer Projectile M898 (SADARM).	AR 9867
E-97	Typical Marking for 165MM Gun Projectiles M123 Series and M623.	AR 100084
E-98	Typical Marking for 175MM Gun Projectile.	AR 100085
E-99	Typical Marking for 8-in. Howitzer Projectile M106.	AR 100086
E-100	Typical Marking for 8-in. Howitzer Projectile M404.	AR 199426-B
E-101	Typical Marking for 8-in. Howitzer Projectile M509A1.	AR 101559-C
E-102	Typical Marking for 8-in. Howitzer Projectile M650.	AR 101580-A
E-103	Typical Marking for 155MM Projectiles M712 and M823 (Copperhead).	AR 198464-A
E-104	Typical Marking for 155MM Howitzer Projectile M864.	AR 2608-A

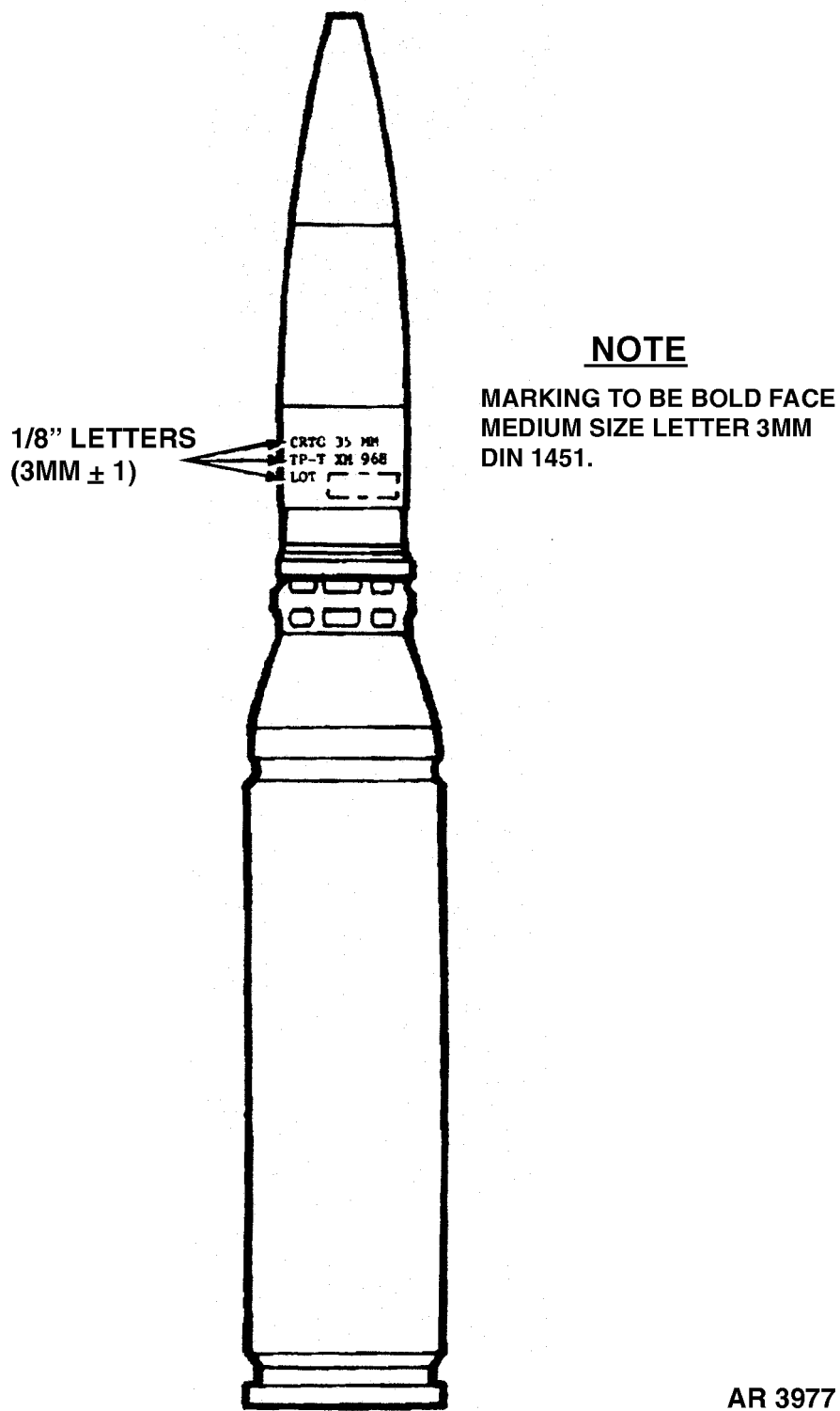
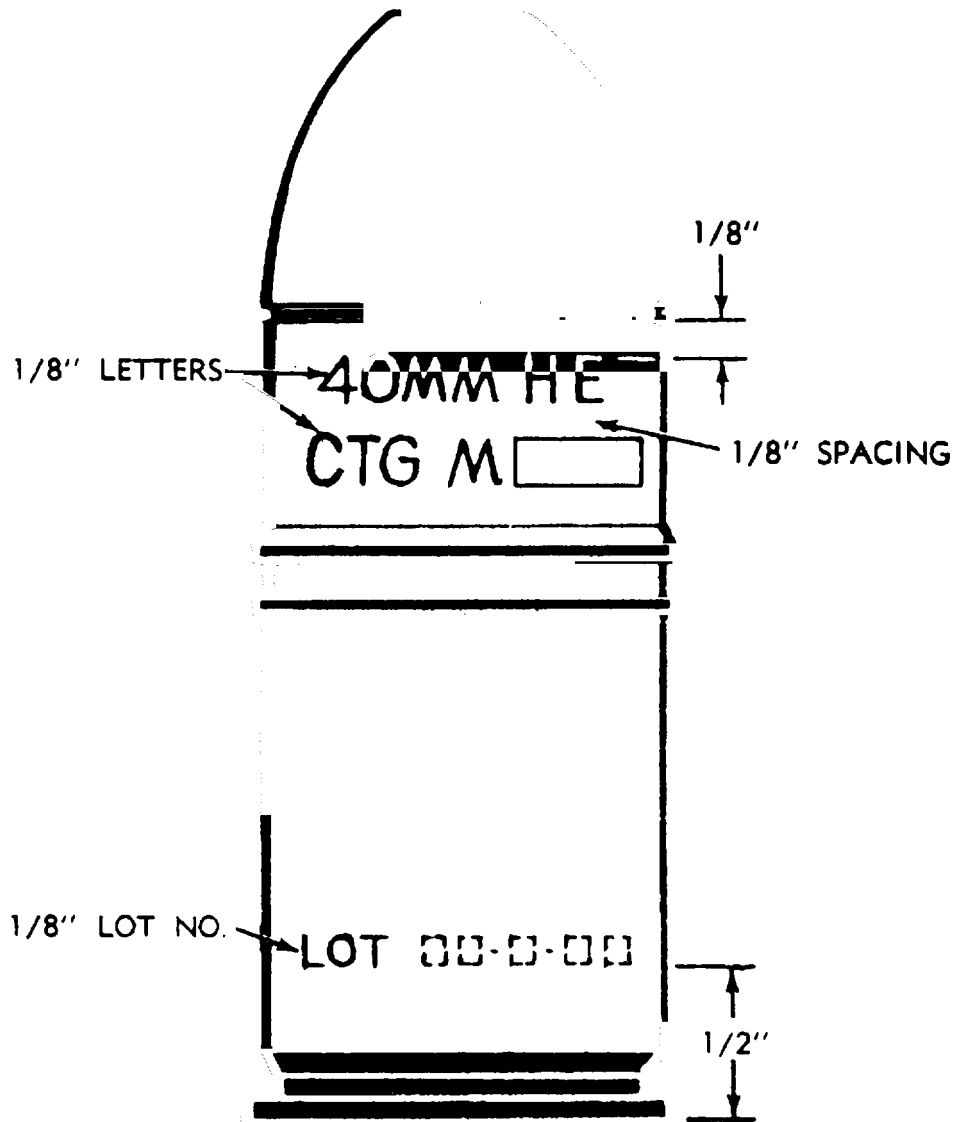

Figure E-1. Typical Marking for 35mm TP-T Cartridge, M968.



AR 100024

Figure E-2. Typical marking for 40mm grenade cartridges M381, M382, M386, M406, M407, and M441 series.

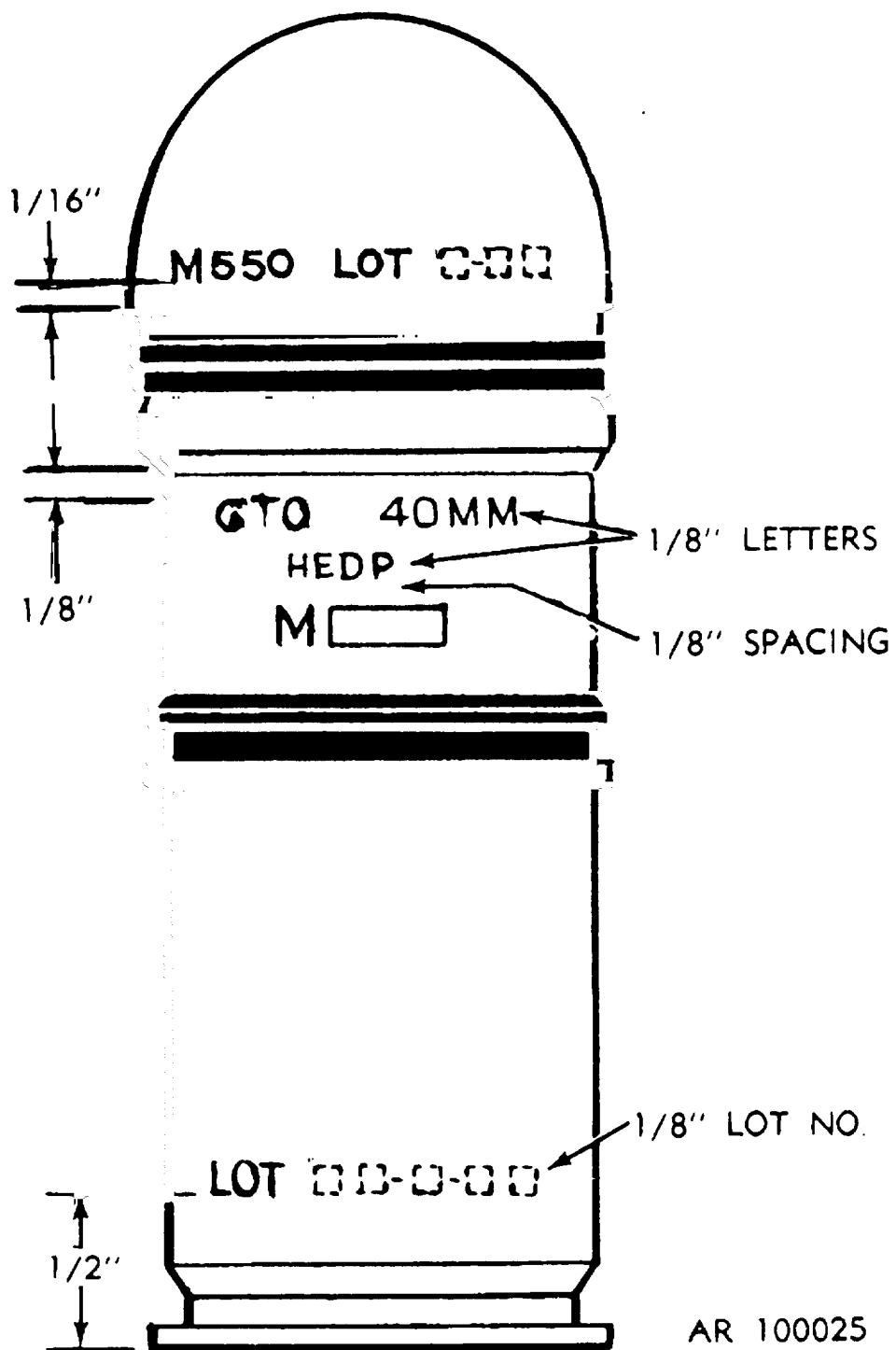

Figure E-3. Typical marking for 40mm grenade cartridge M433.

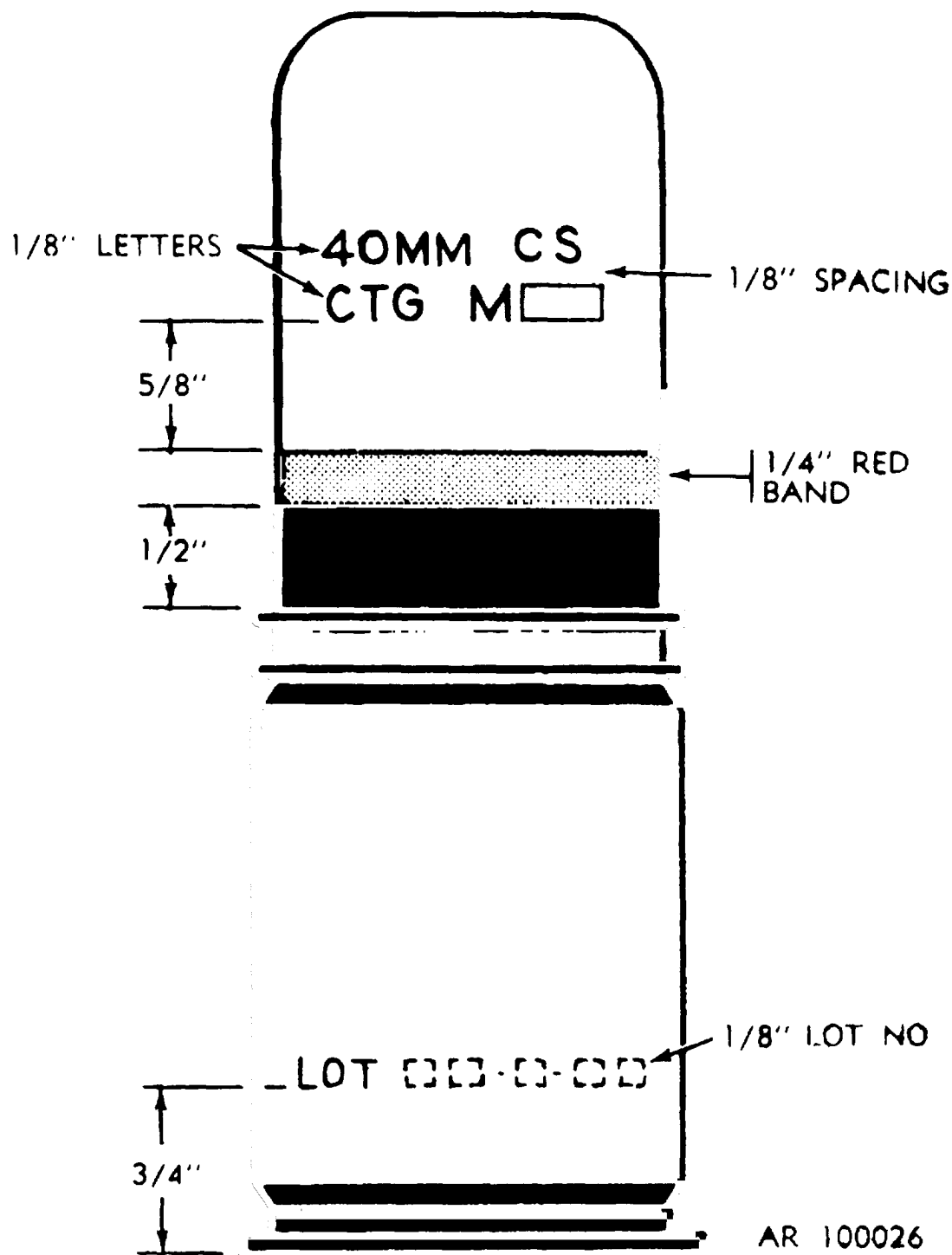

Figure E-4. Typical marking for 40mm grenade cartridge M651.

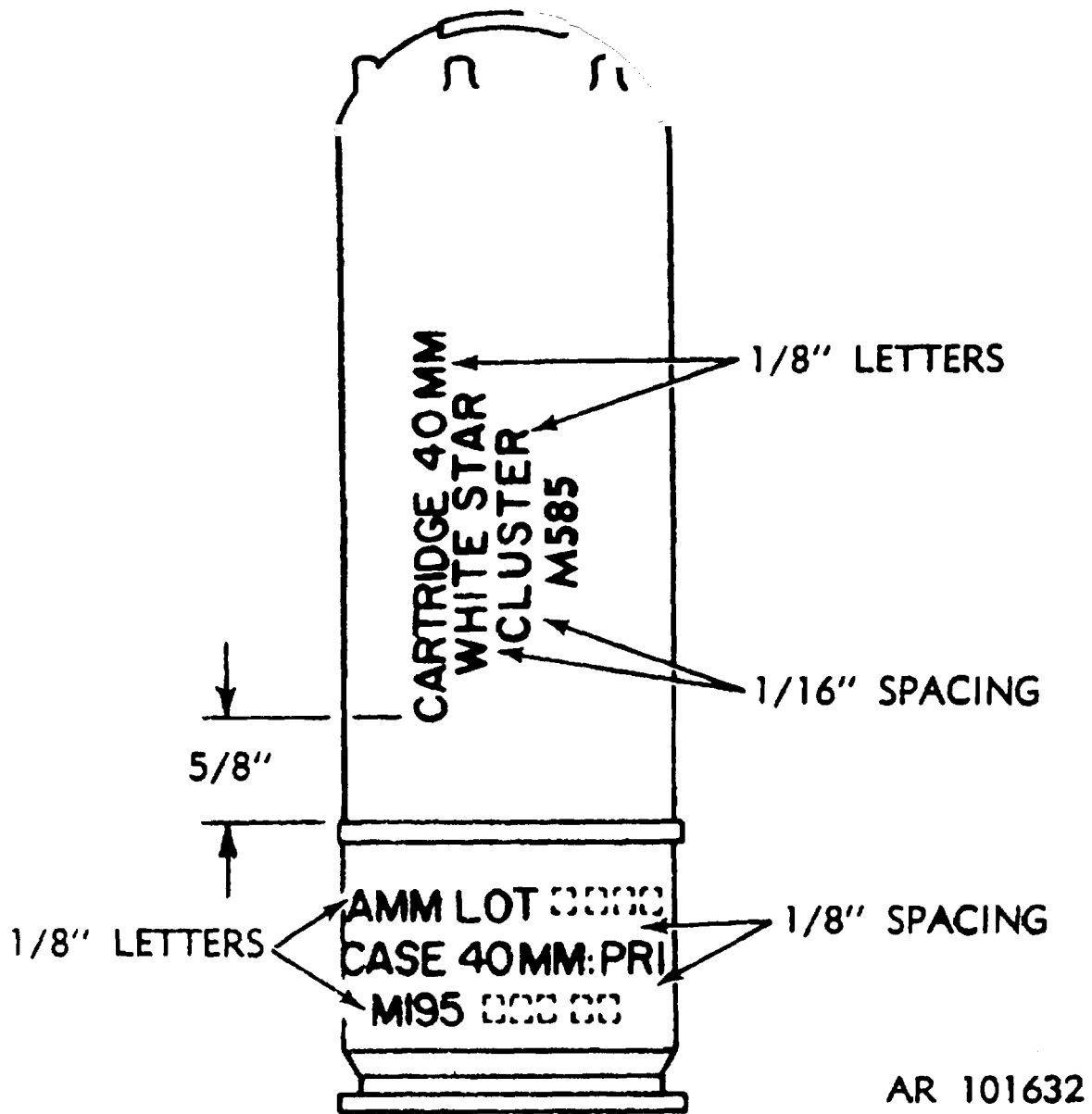
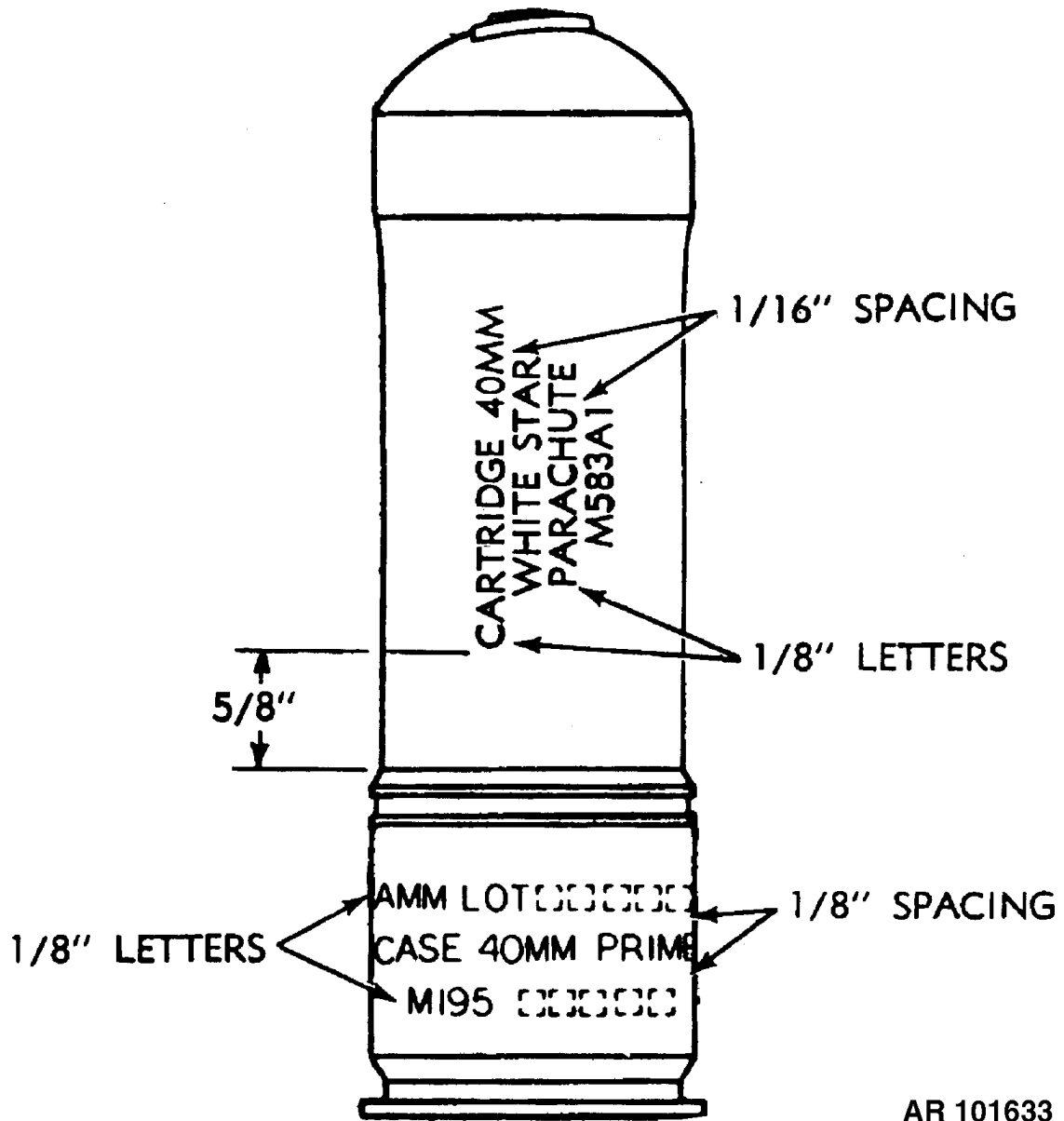

Figure E-5. Typical marking for 40mm grenade cartridge M585.



AR 101633

Figure E-6. Typical marking for 40mm grenade cartridges M583A1, M661, M662, and M992.

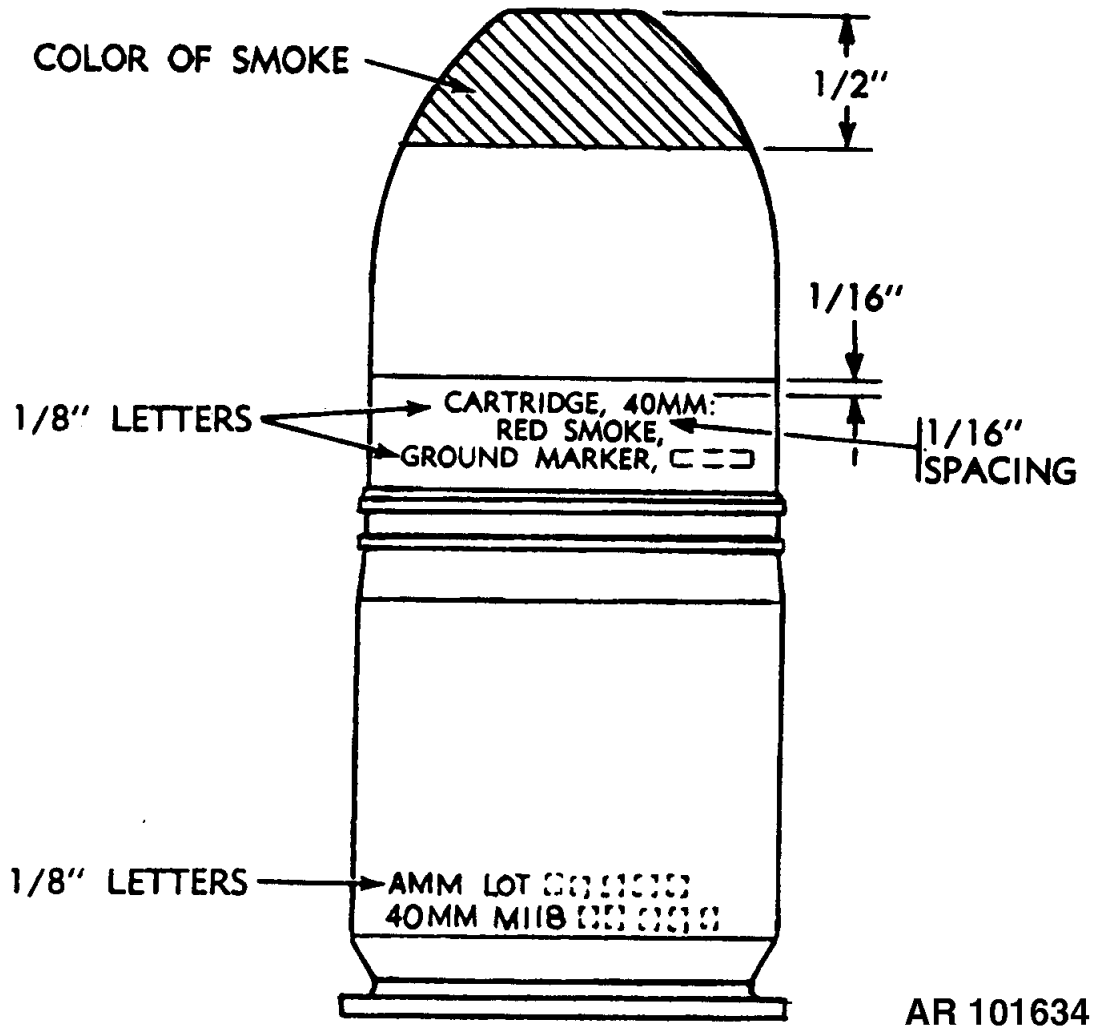

Figure E-7. Typical marking for 40mm grenade cartridges M713, M715 and M716.

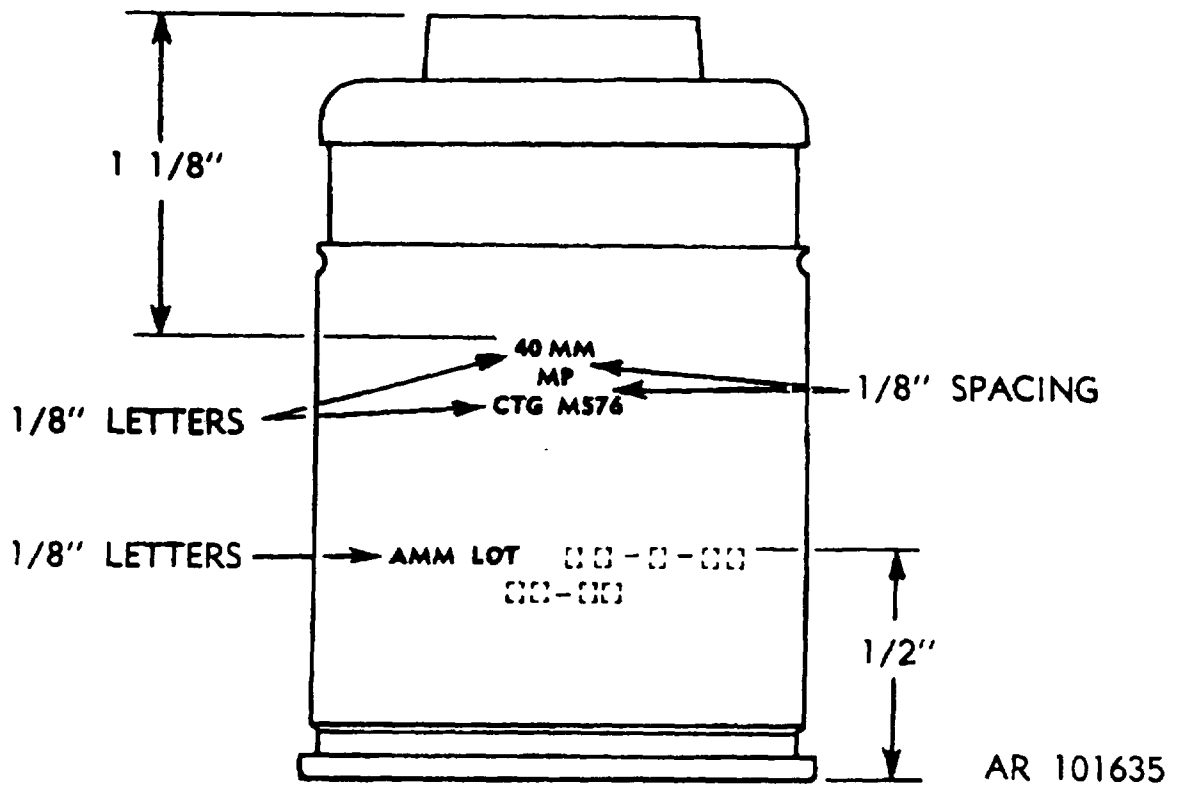

Figure E-8. Typical marking for 40mm grenade cartridge M576.

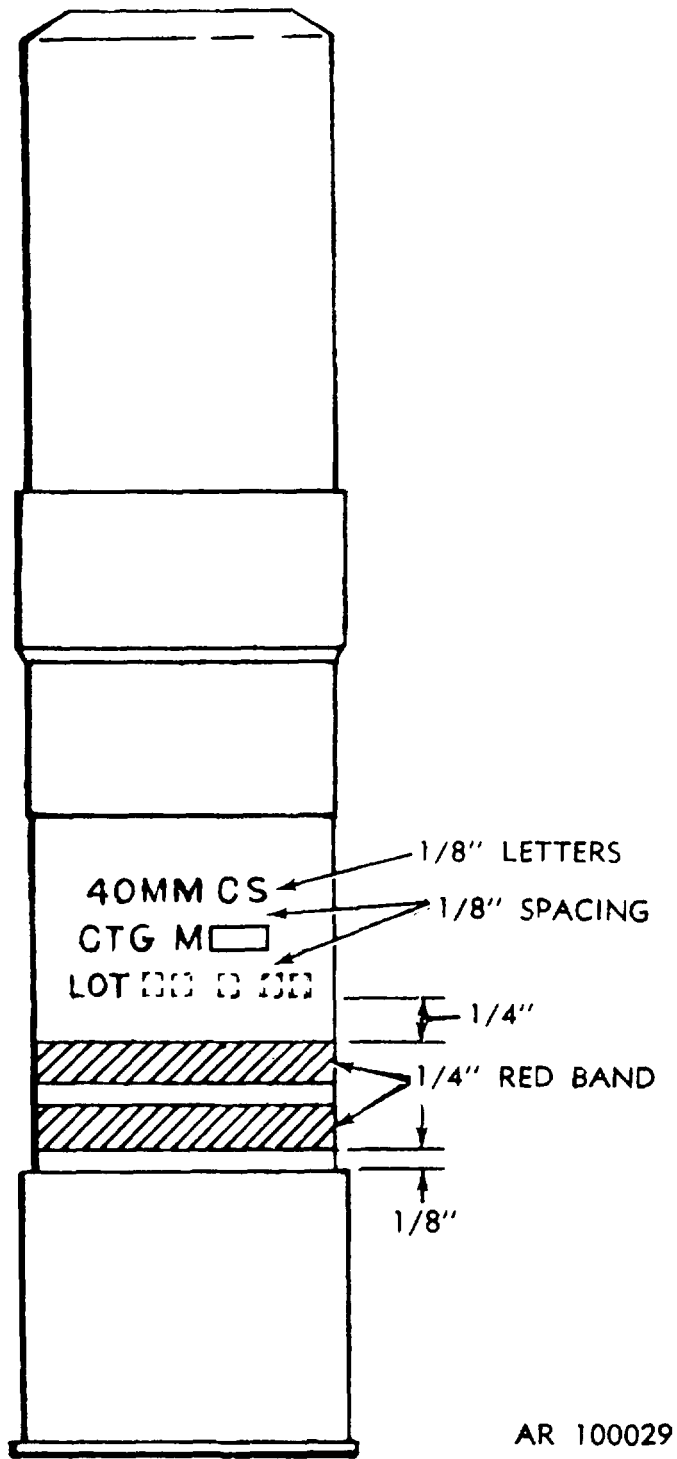

Figure E-9. Typical marking for 40mm grenade cartridges M674 and M675.

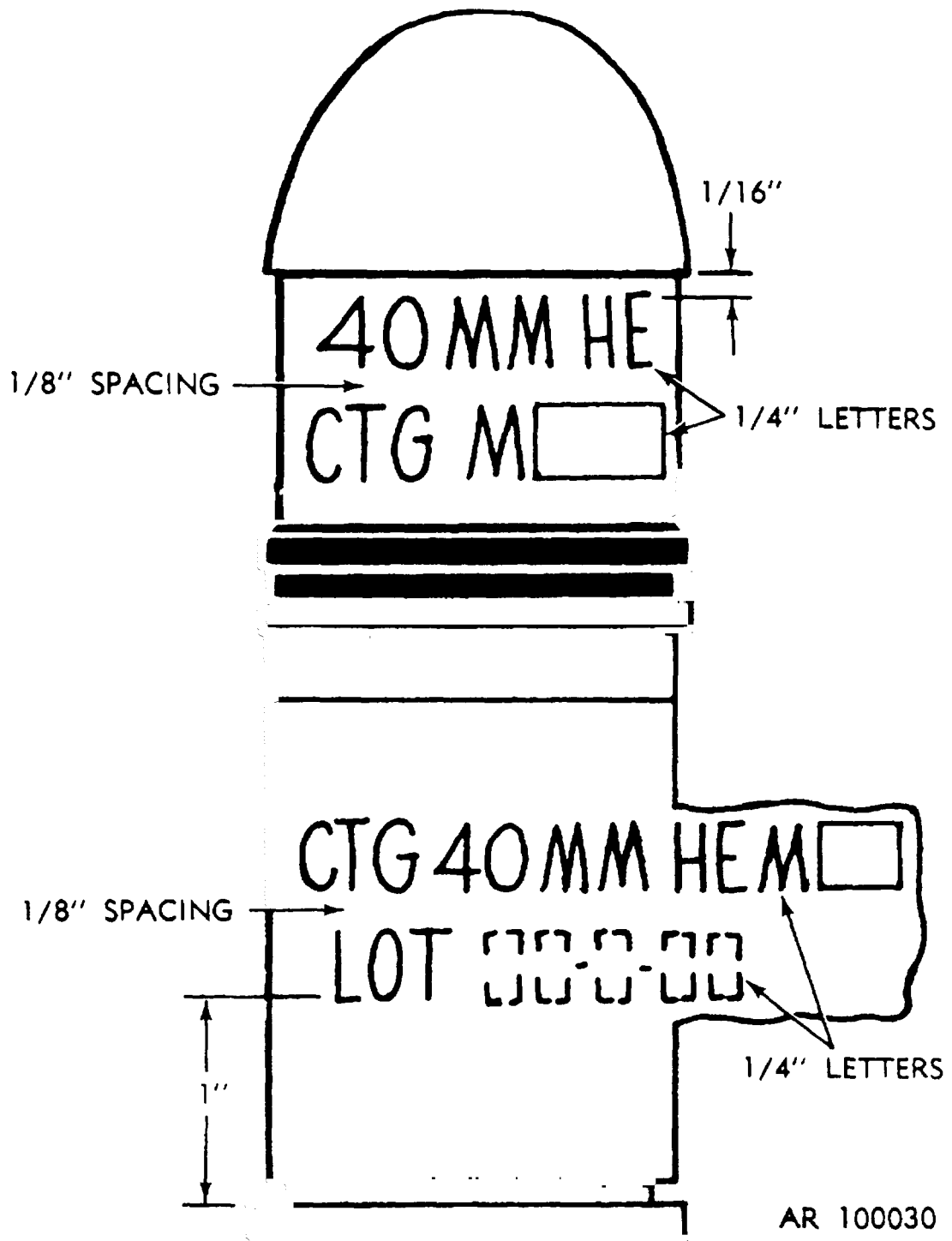

Figure E-10. Typical marking for 40mm grenade cartridges M383, M384 and M684.

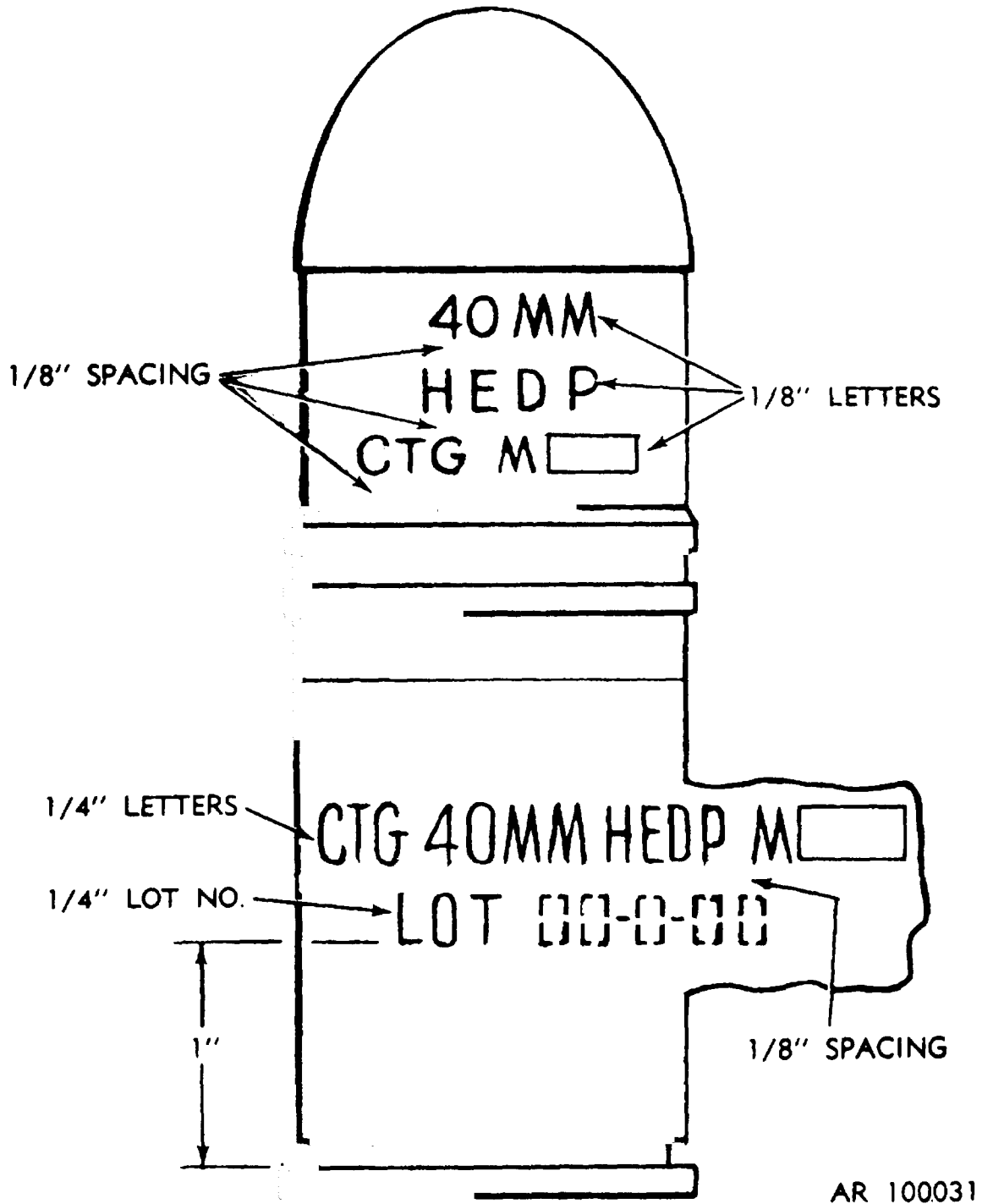
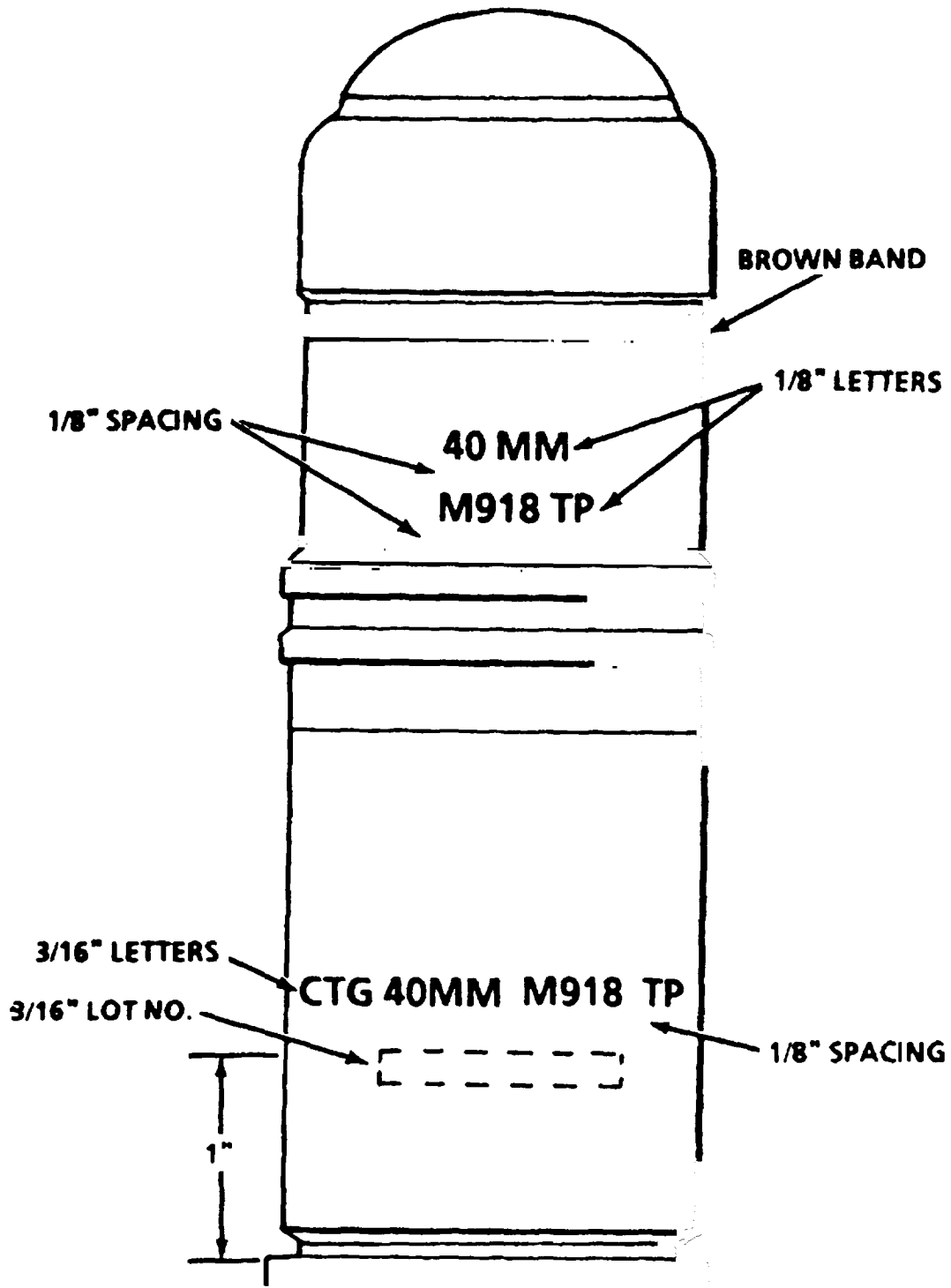
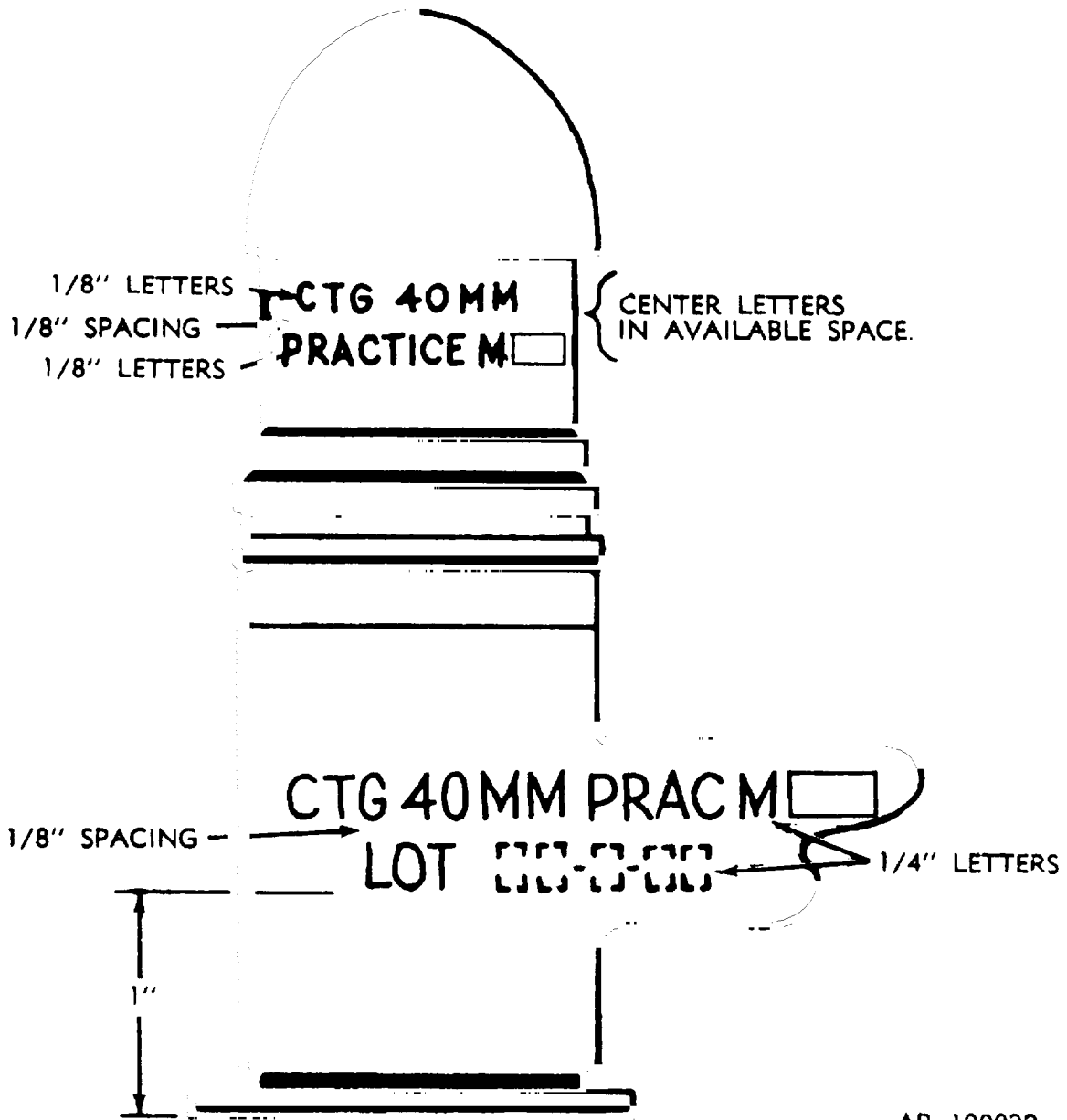

Figure E-11. Typical marking for 40mm grenade cartridge M430.



U
AR 2665-A

Figure E-12. Typical marking for 40mm grenade cartridge M918.



AR 100032

Figure E-13. Typical marking for 40mm grenade cartridge M385.

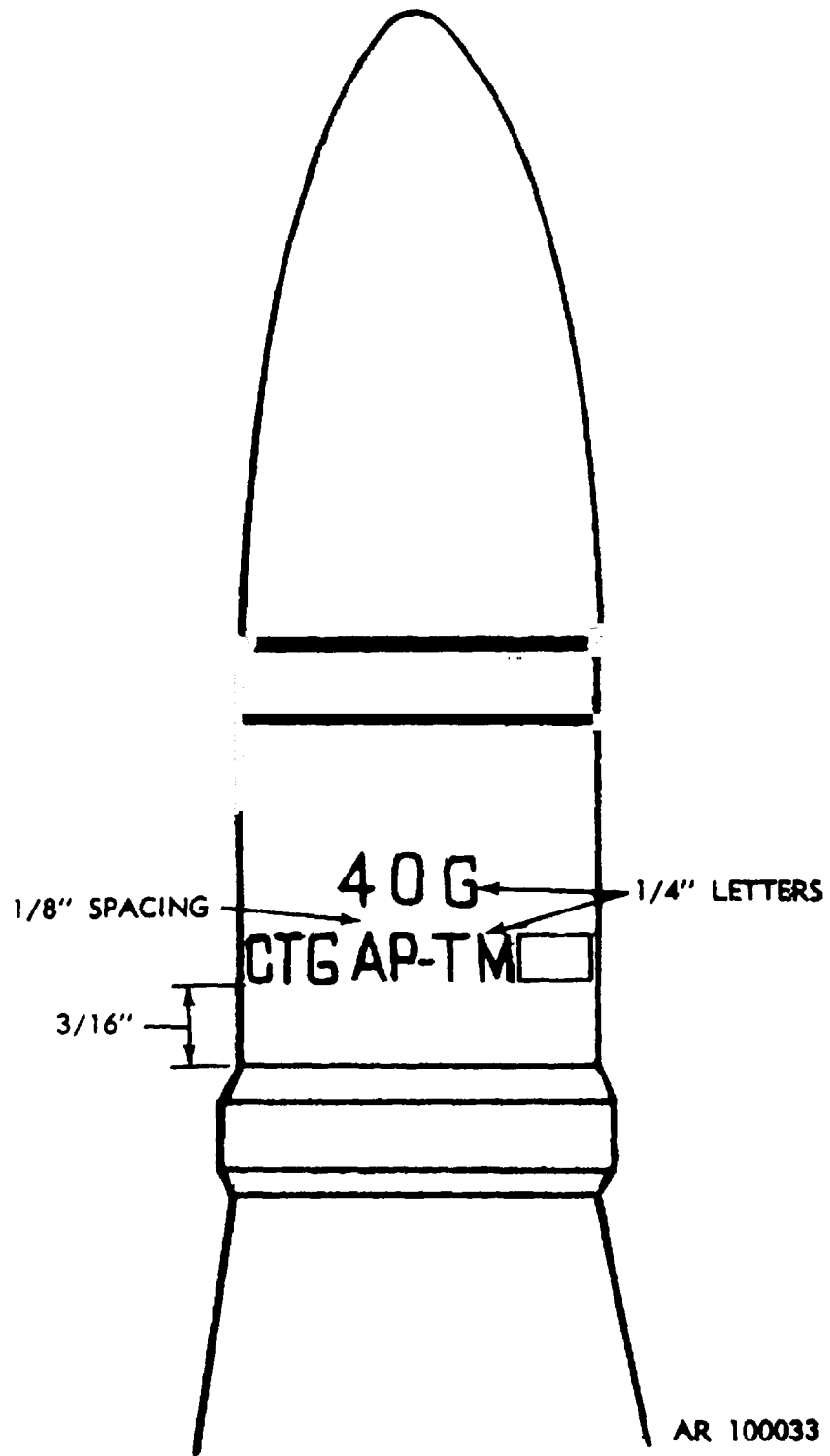

Figure E-14. Typical marking for 40mm cartridge M81A1.

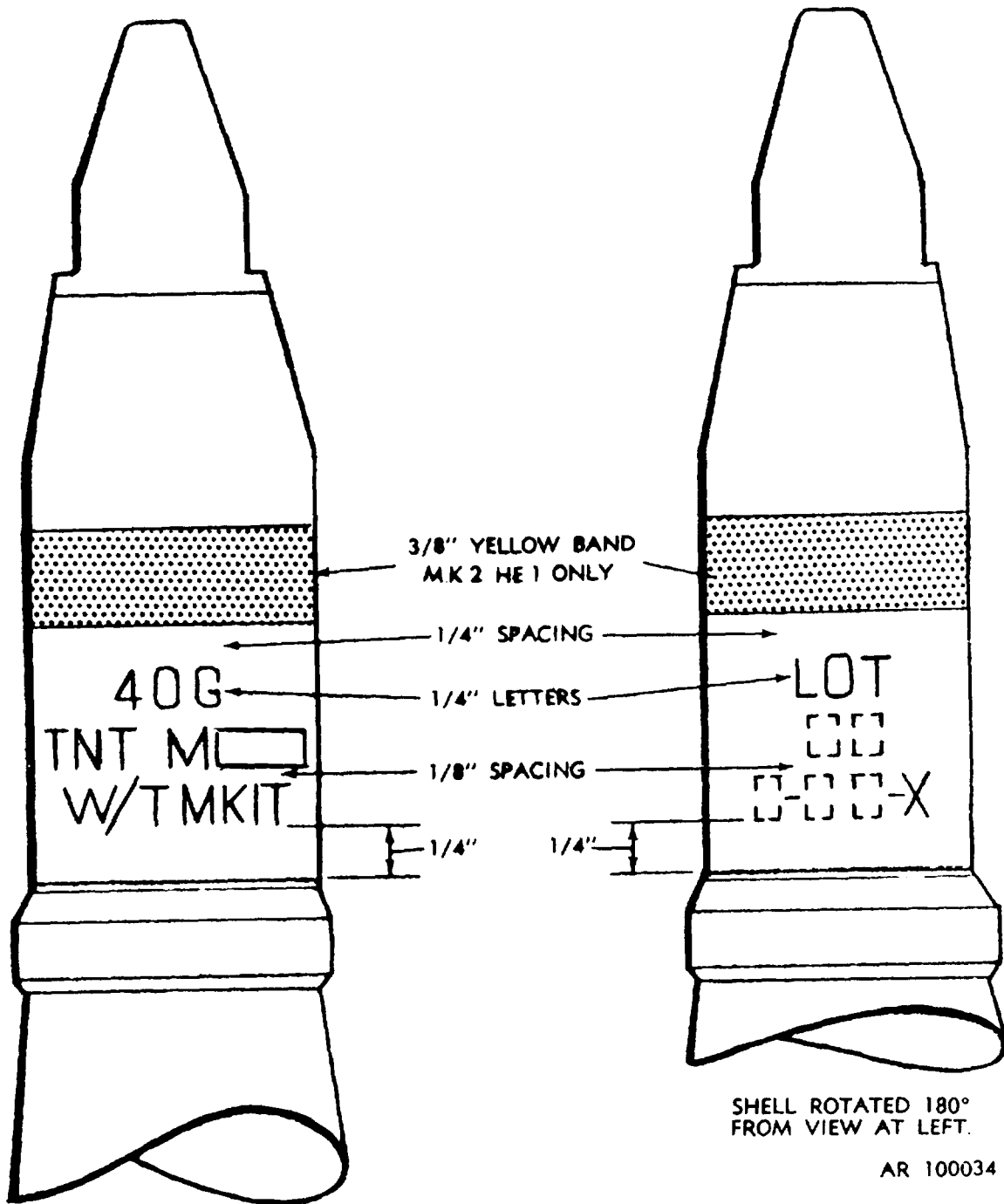

Figure E-15. Typical marking for 40mm gun cartridges Mk2, M25 and M91.

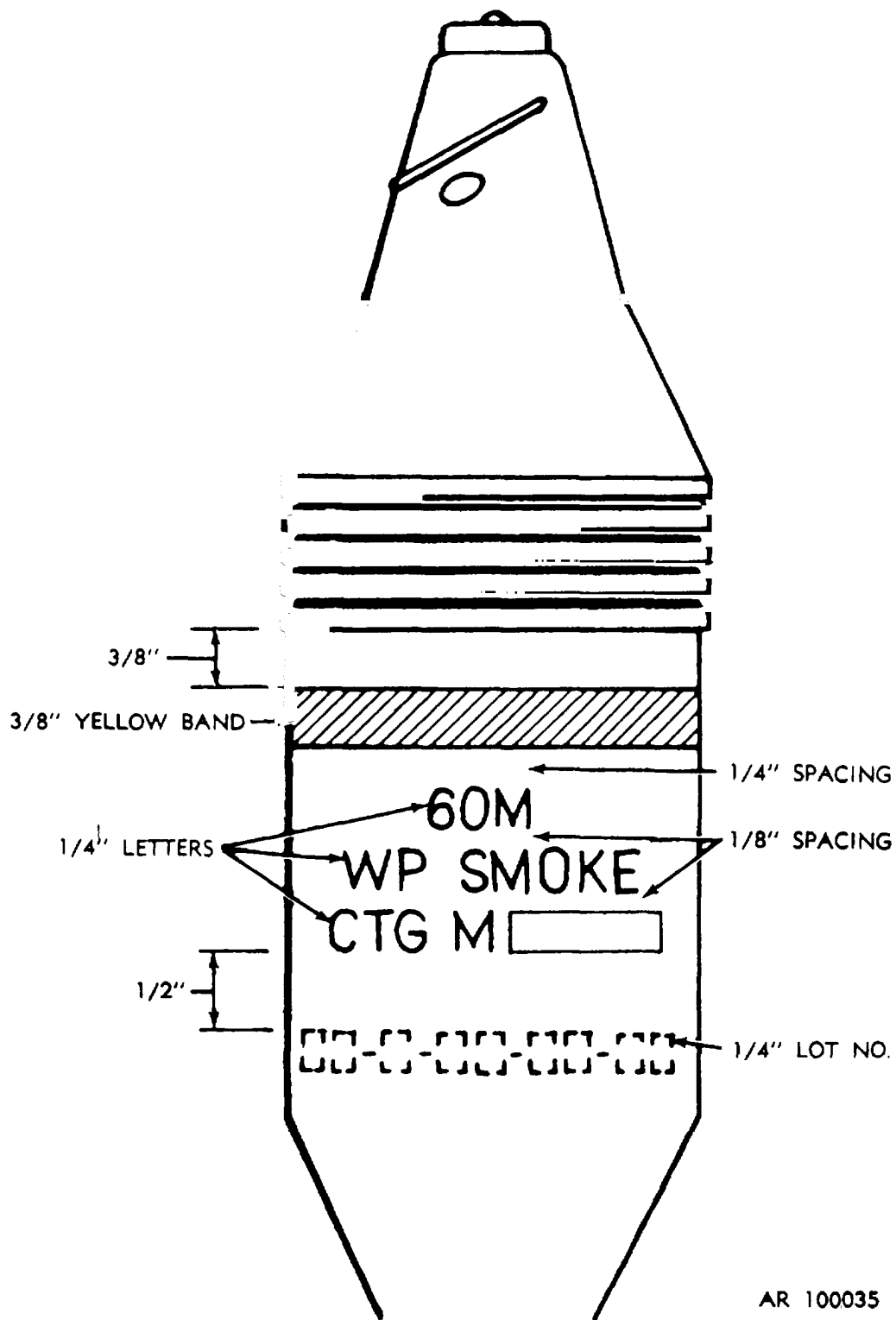
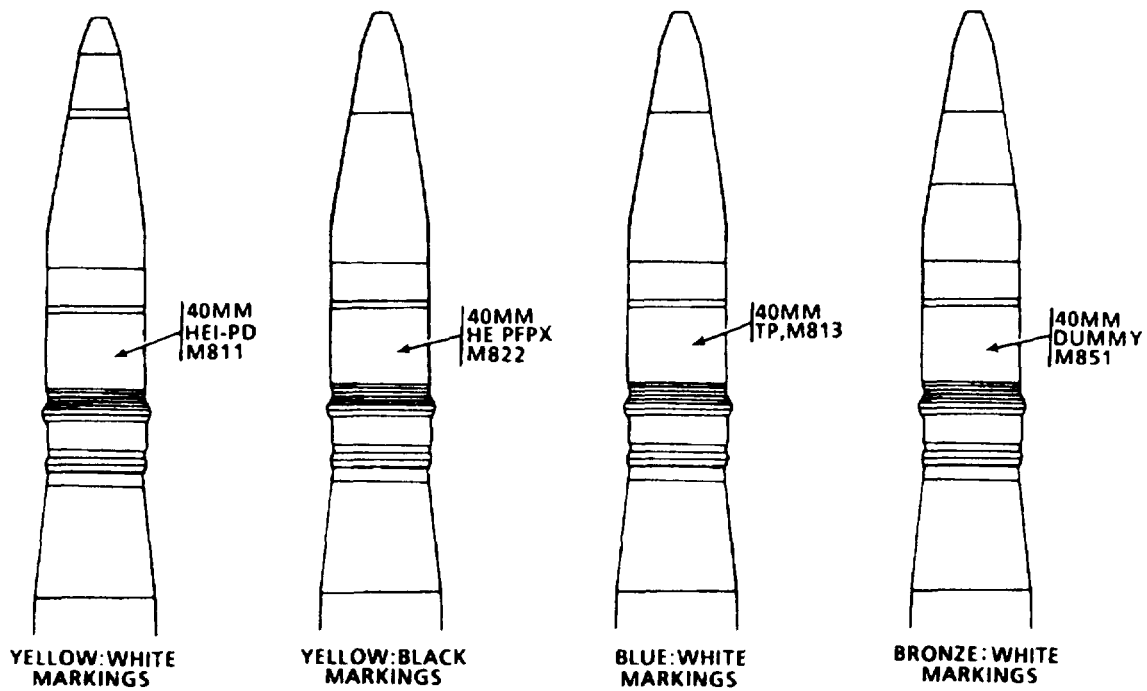

Figure E-16. Typical marking for 60mm mortar cartridges M302 series.



Markings stenciled on projectiles are:

- Caliber and type of weapon
- Type of projectile
- Model projectile (A.R.)

ARD 84-1609

Figure E-17. Typical marking for 40mm gun cartridges M811, M813, M822 and M851 (SGT York).

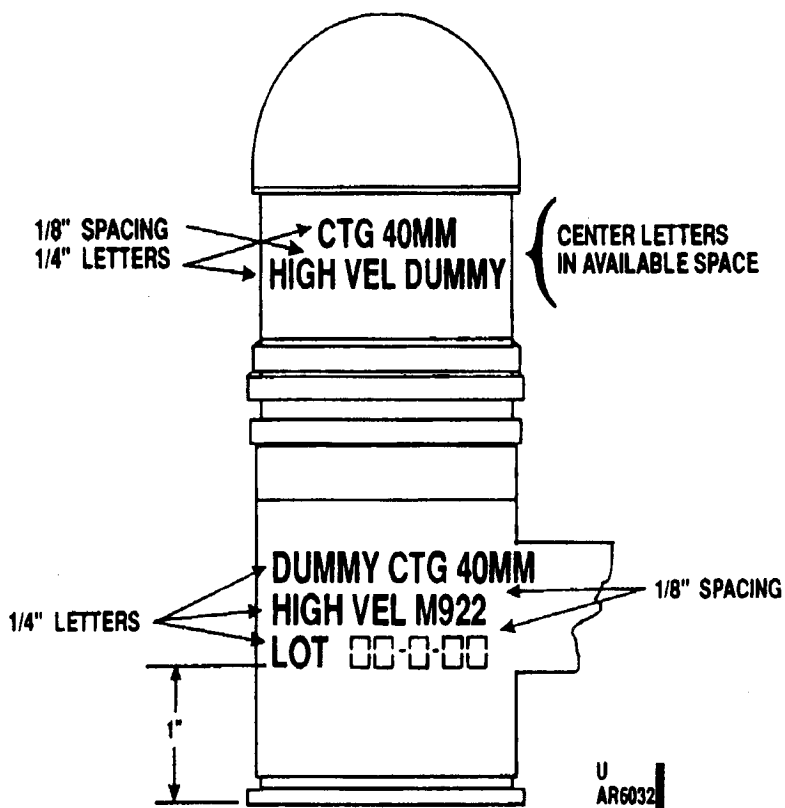
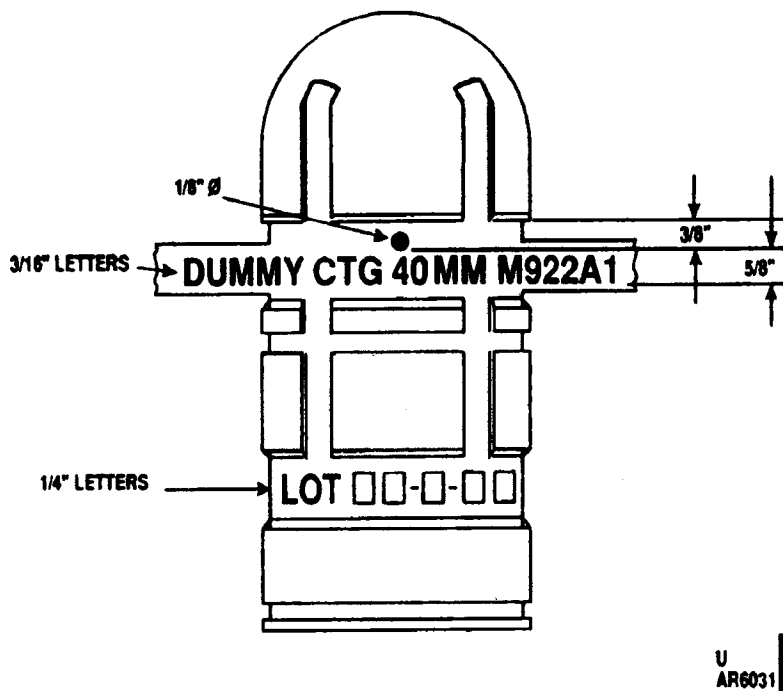

Figure E-17.1. Typical marking for 40mm dummy cartridge M922.



U
AR6031

Figure E-17.2. Typical marking for 40mm dummy cartridge M922A1.

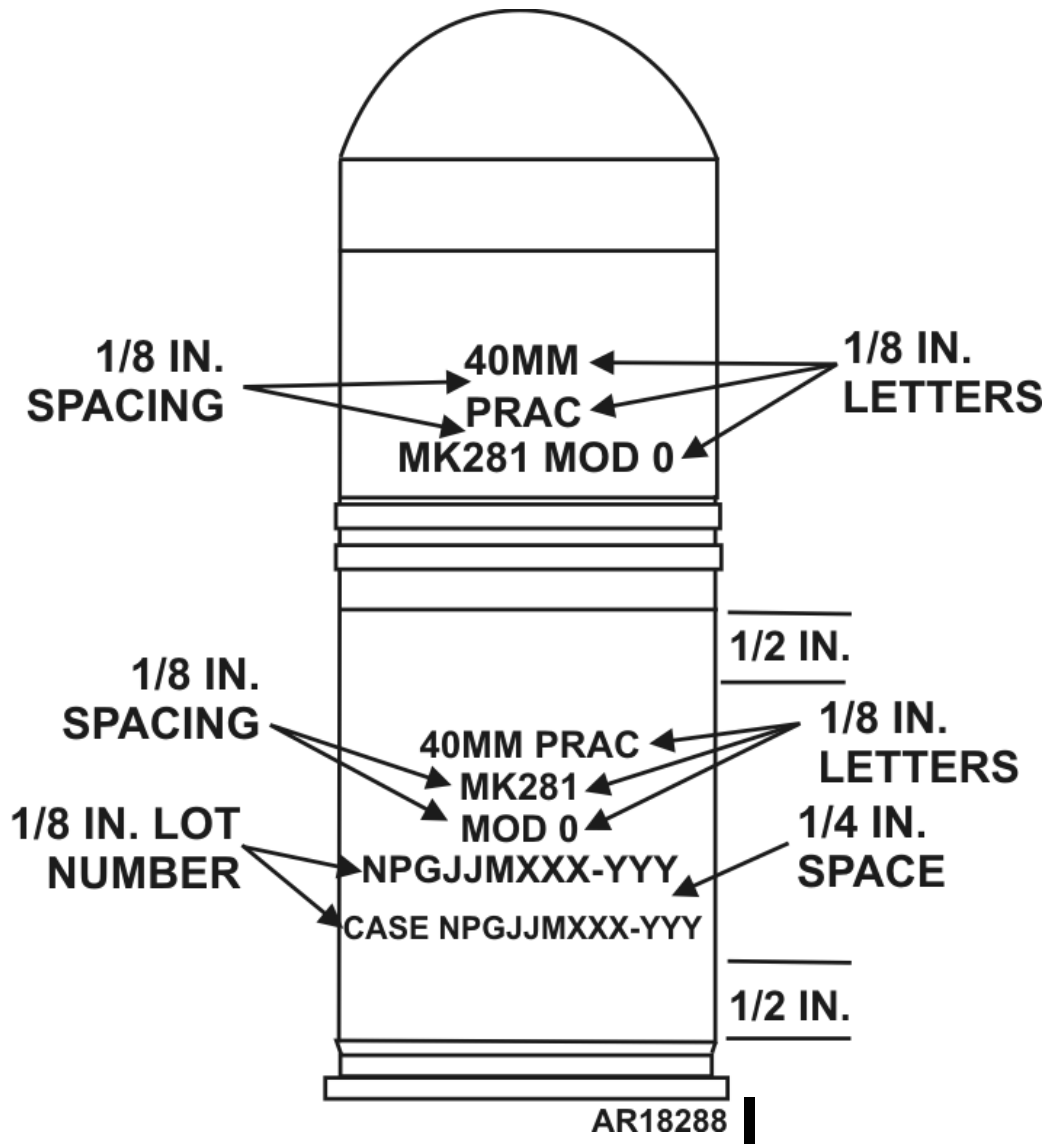

Figure E-17.3. Typical marking for 40mm grenade cartridge MK281 MOD 0.

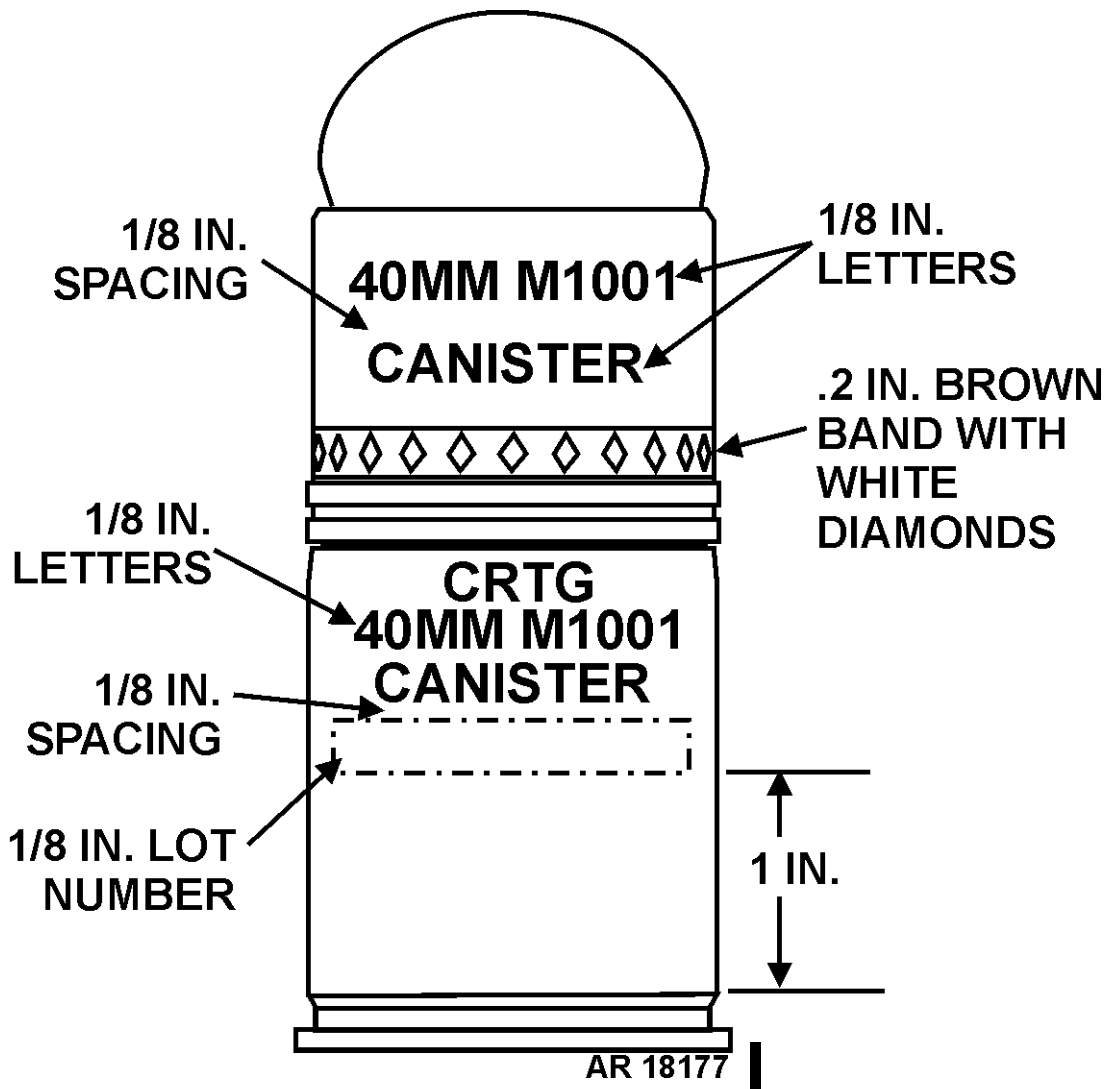

Figure E-17.4. Typical marking for 40mm grenade cartridge M1001.

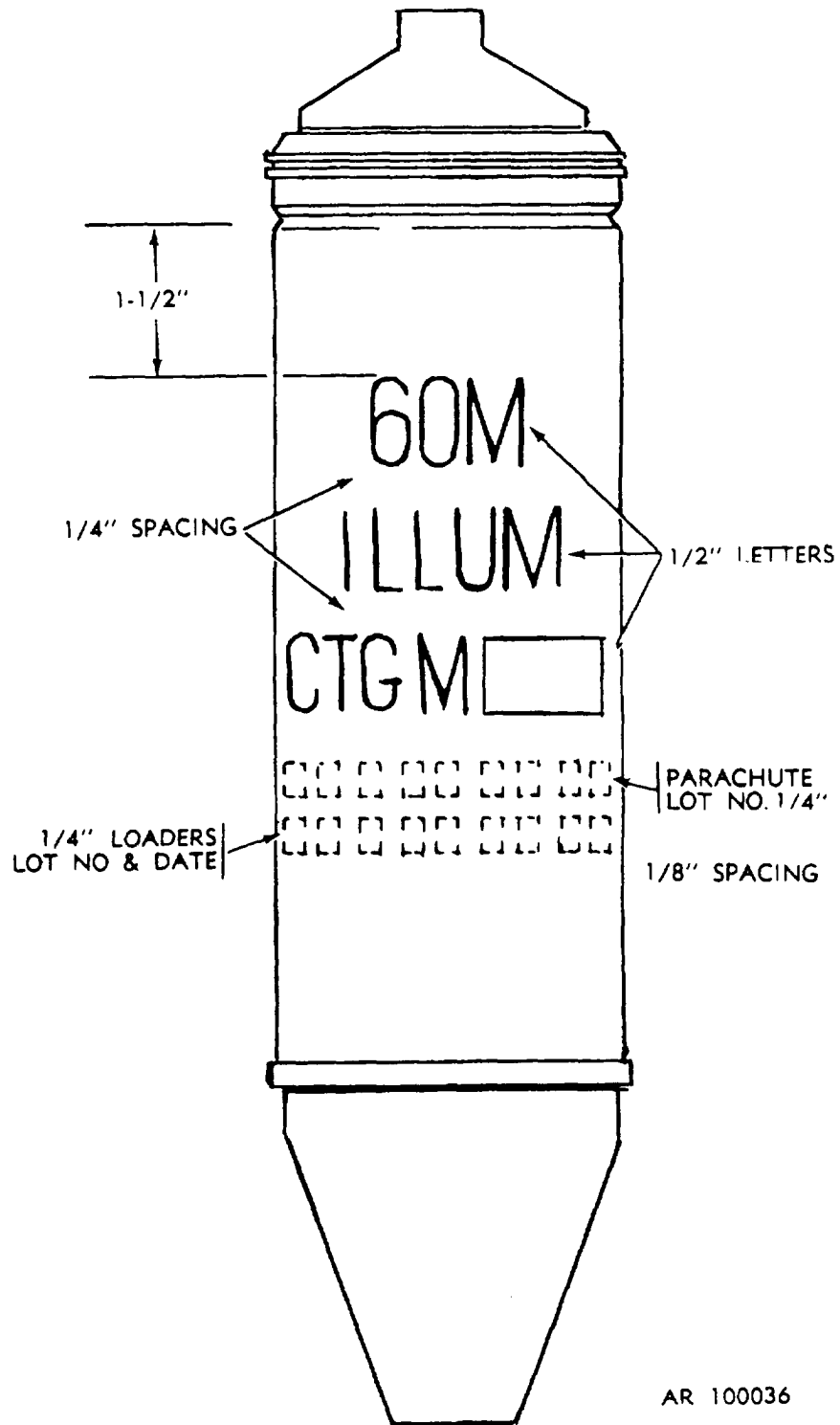

Figure E-18. Typical marking for 60mm mortar cartridges M83 series.

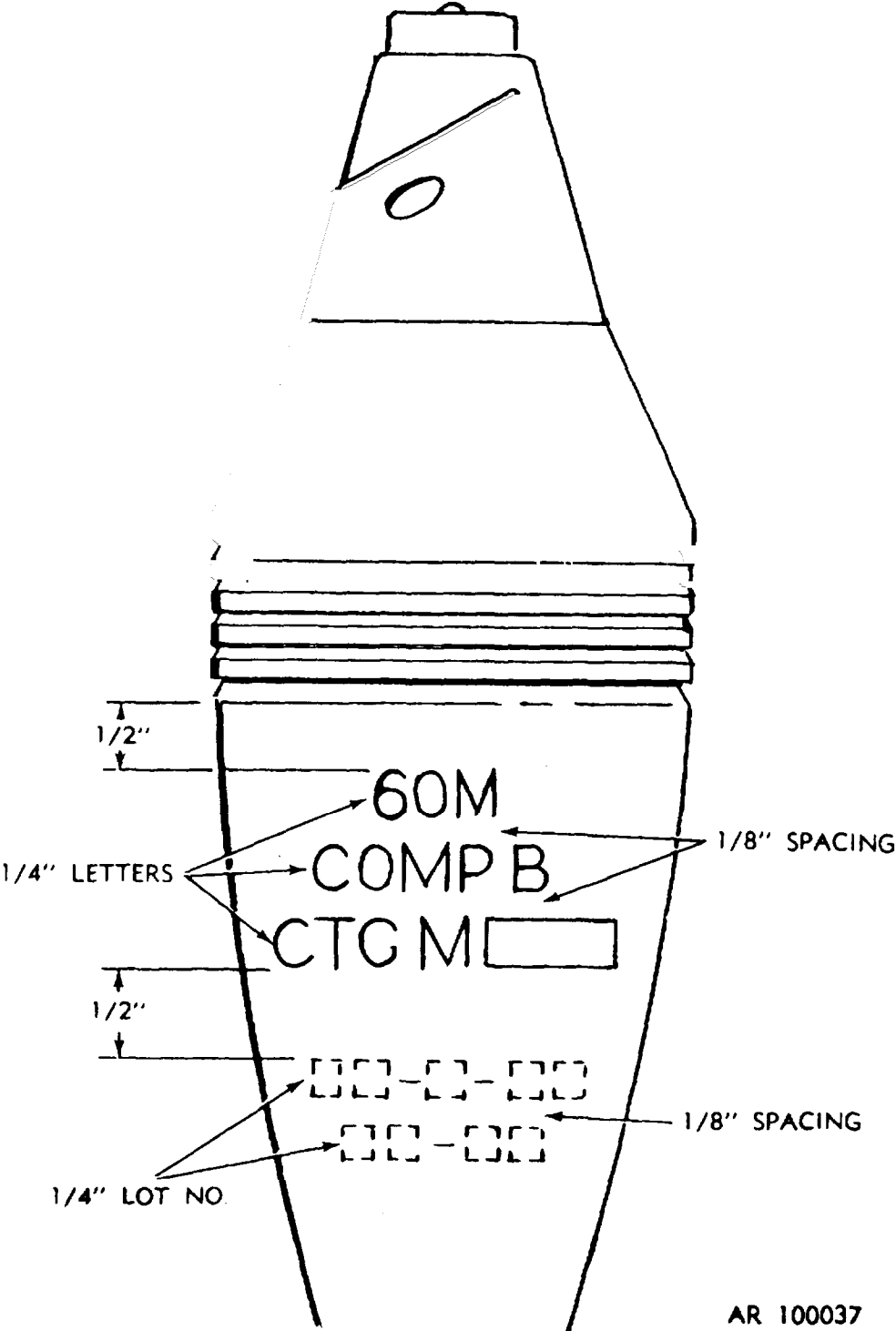

Figure E-19. Typical marking for 60mm mortar cartridges M49 series, M50 series and M720.

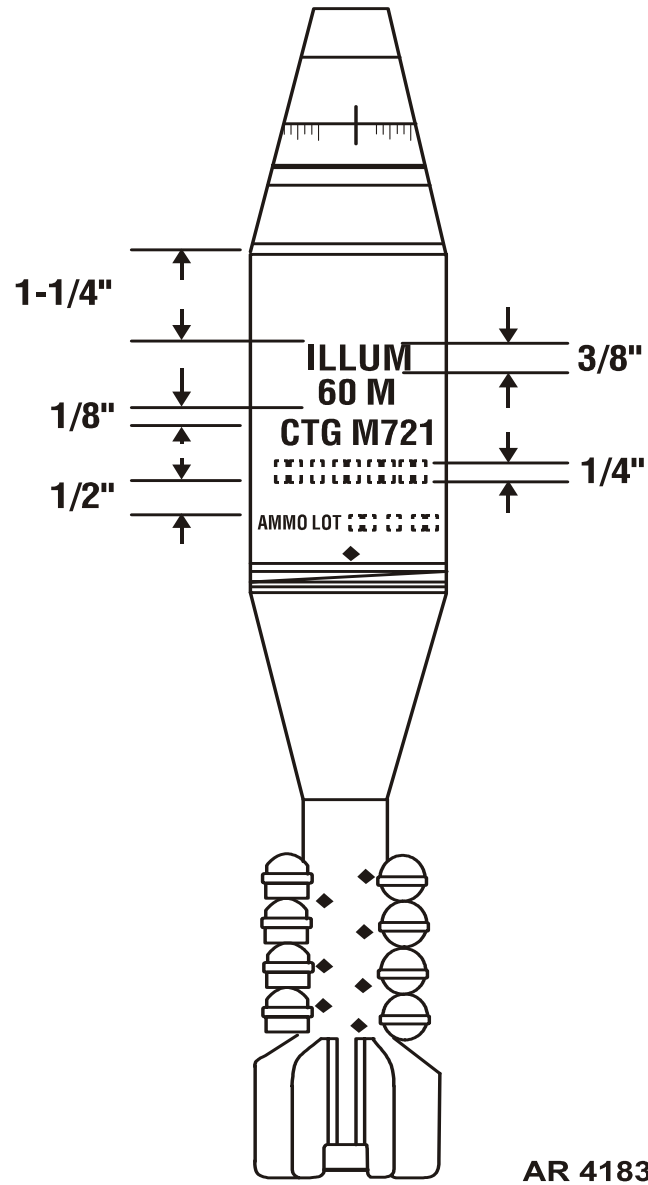

Figure E-20. Typical marking for 60mm Mortar Cartridge M721.

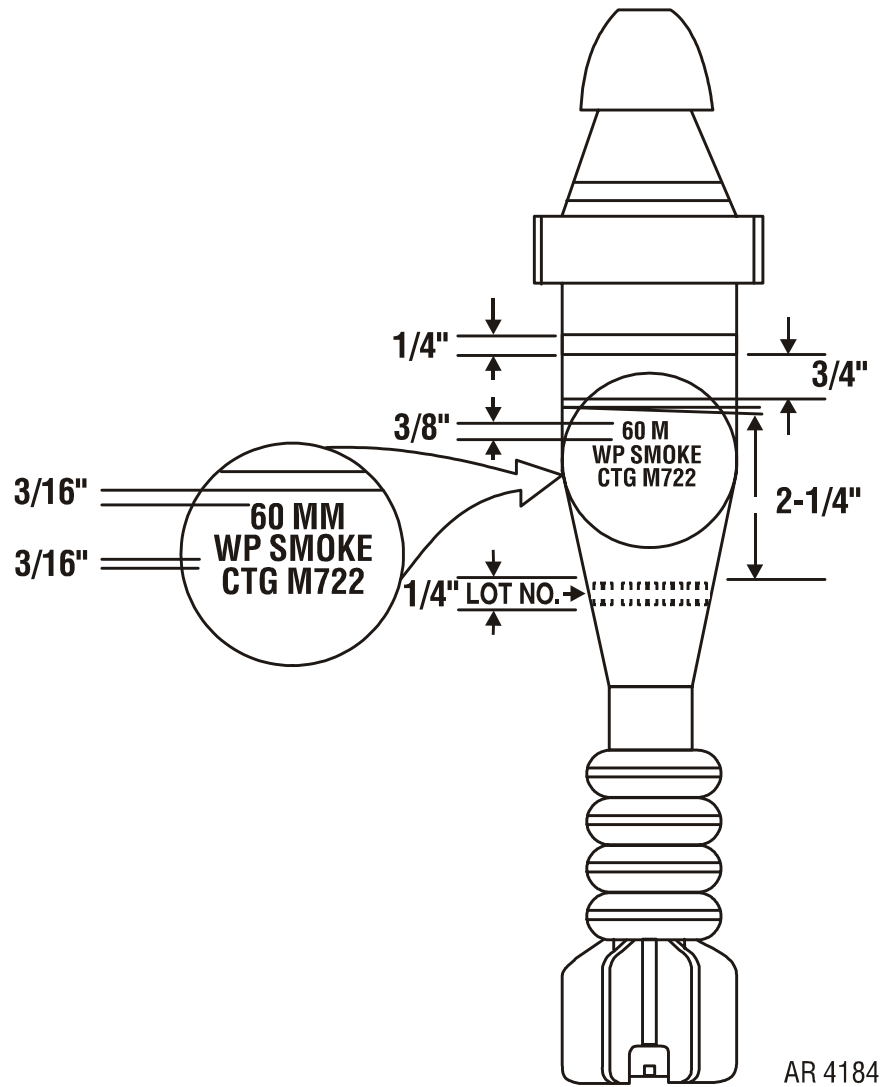

Figure E-21. Typical marking for 60mm Mortar Cartridges M722 and M722A1.

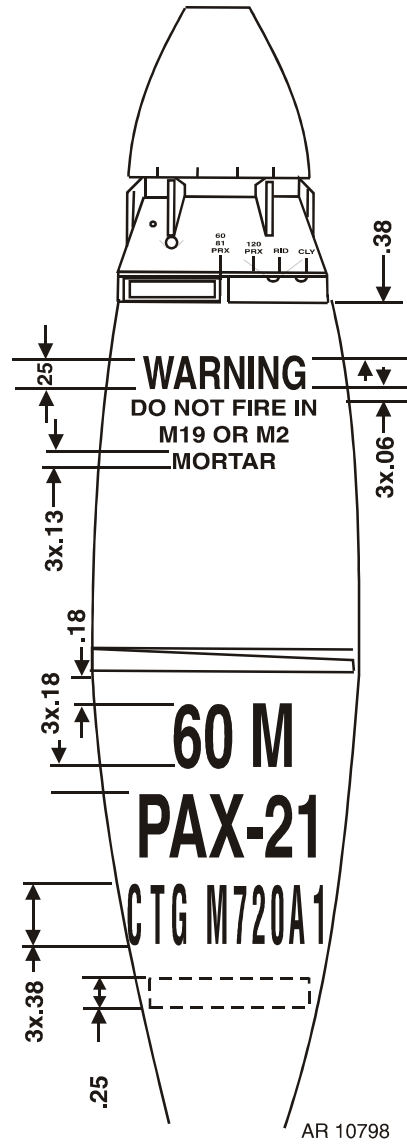

Figure E-21.1 Typical marking for 60mm Mortar Cartridges M720A1 and M768.

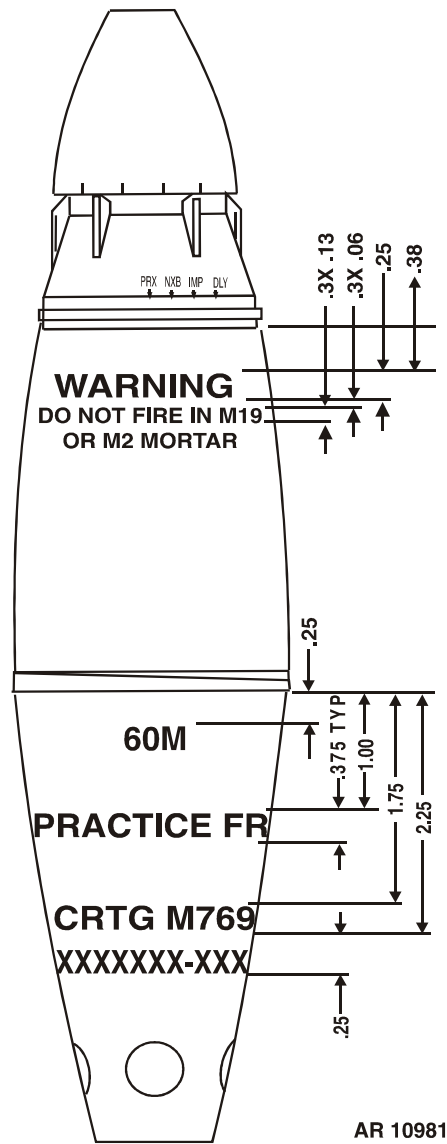
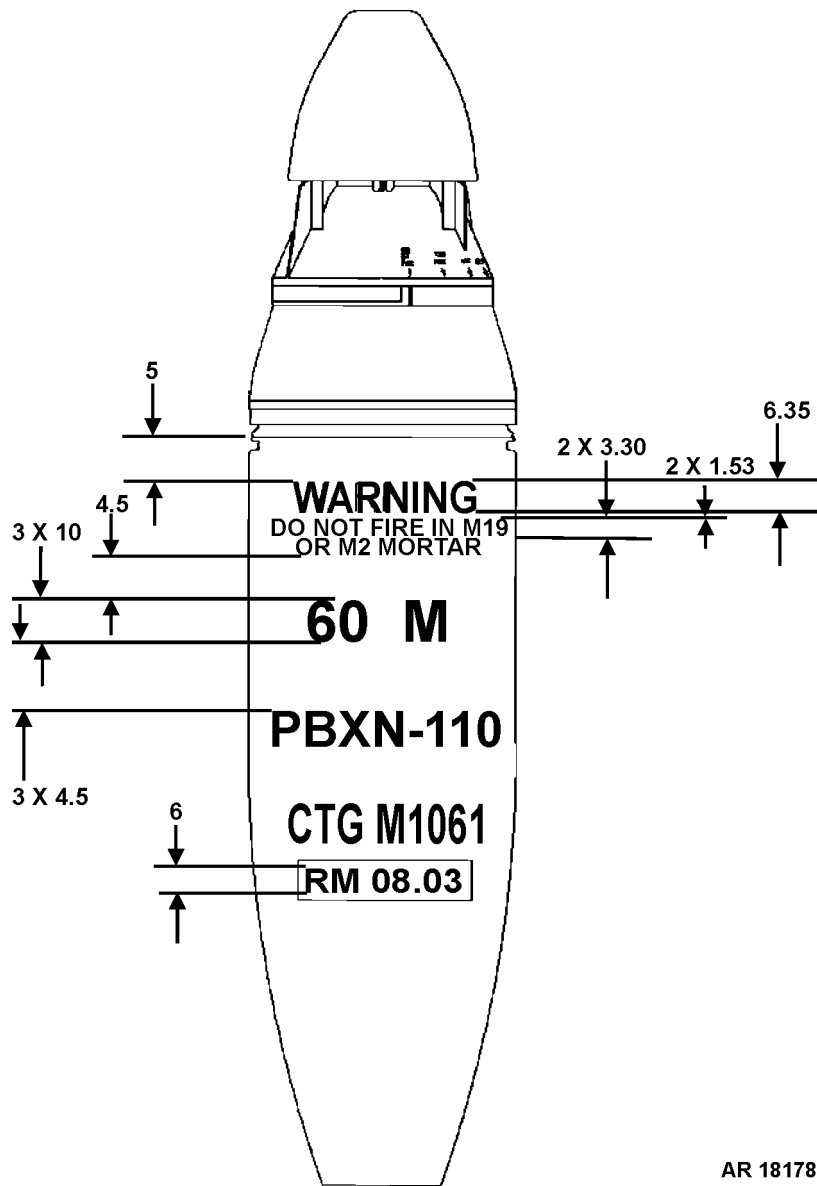

Figure E-21.2 Typical marking for 60mm Mortar Cartridge M769.



AR 18178

NOTE: Units are in millimeters.

Figure E-21.3. Typical marking for 60mm mortar cartridge M1061.

THIS PAGE INTENTIONALLY LEFT BLANK

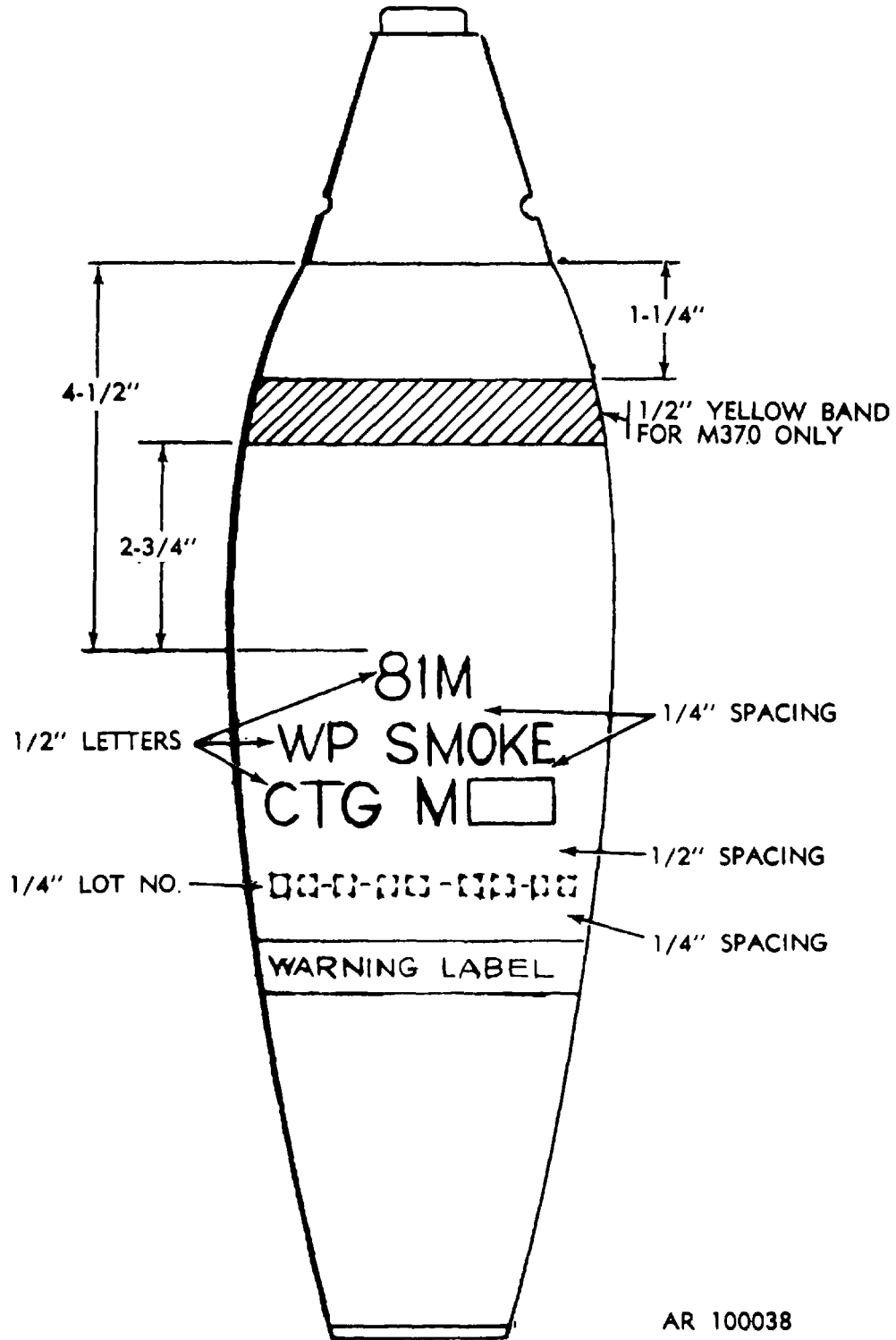
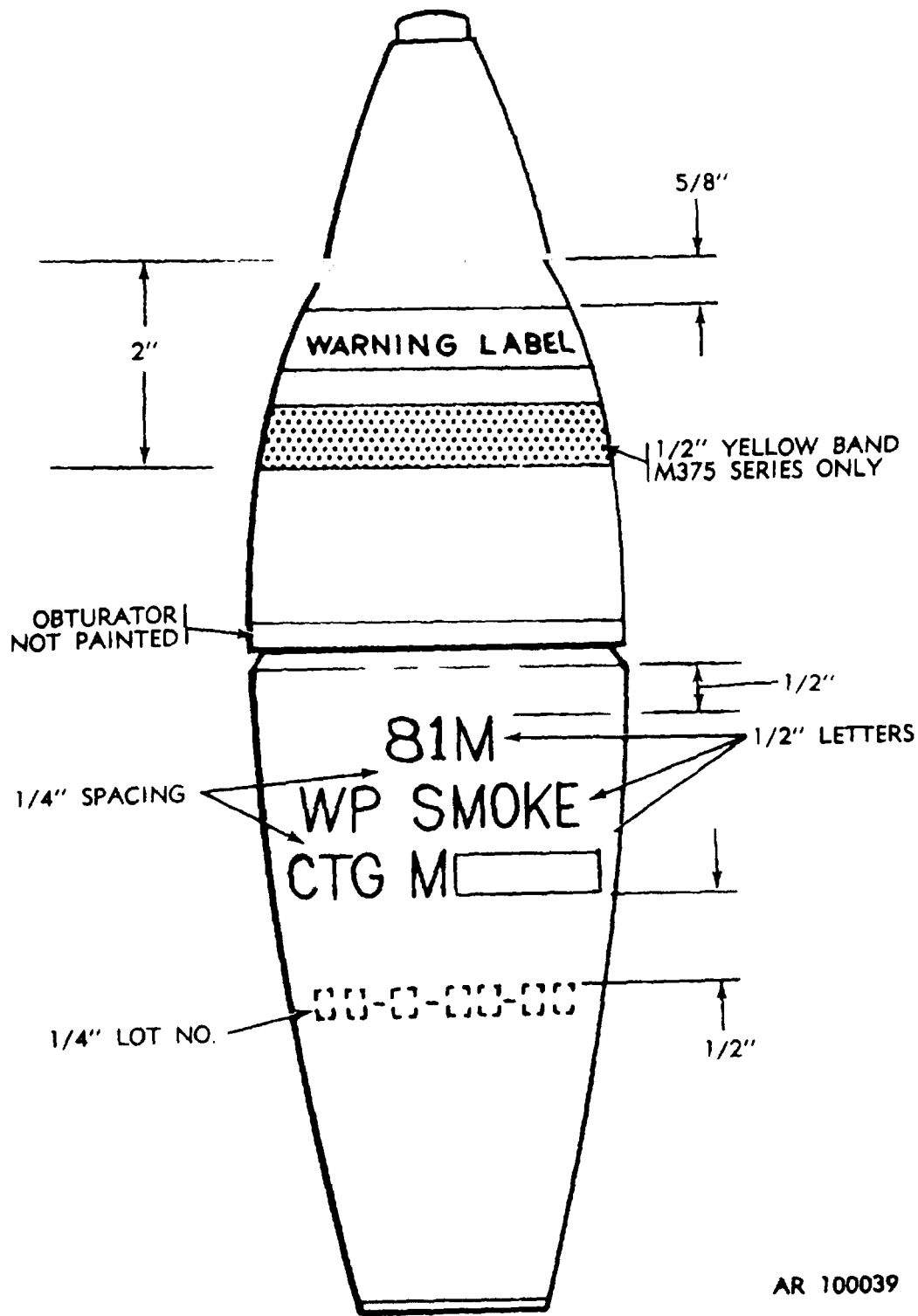

Figure E-22. Typical marking for 81mm mortar cartridges M362 series, M370 and M445.



AR 100039

Figure E-23. Typical marking for 81mm mortar cartridges M374 series and M375 series.

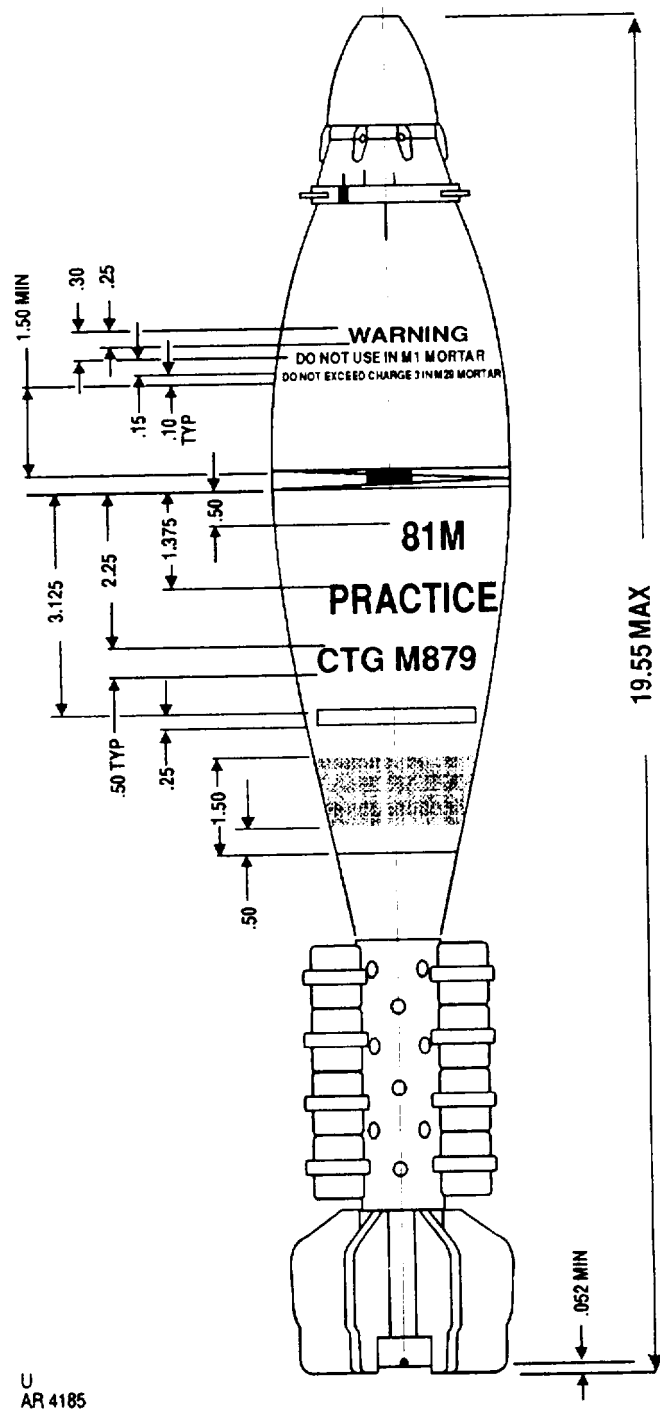

Figure E-24. Typical marking for 81mm mortar cartridge XM879.

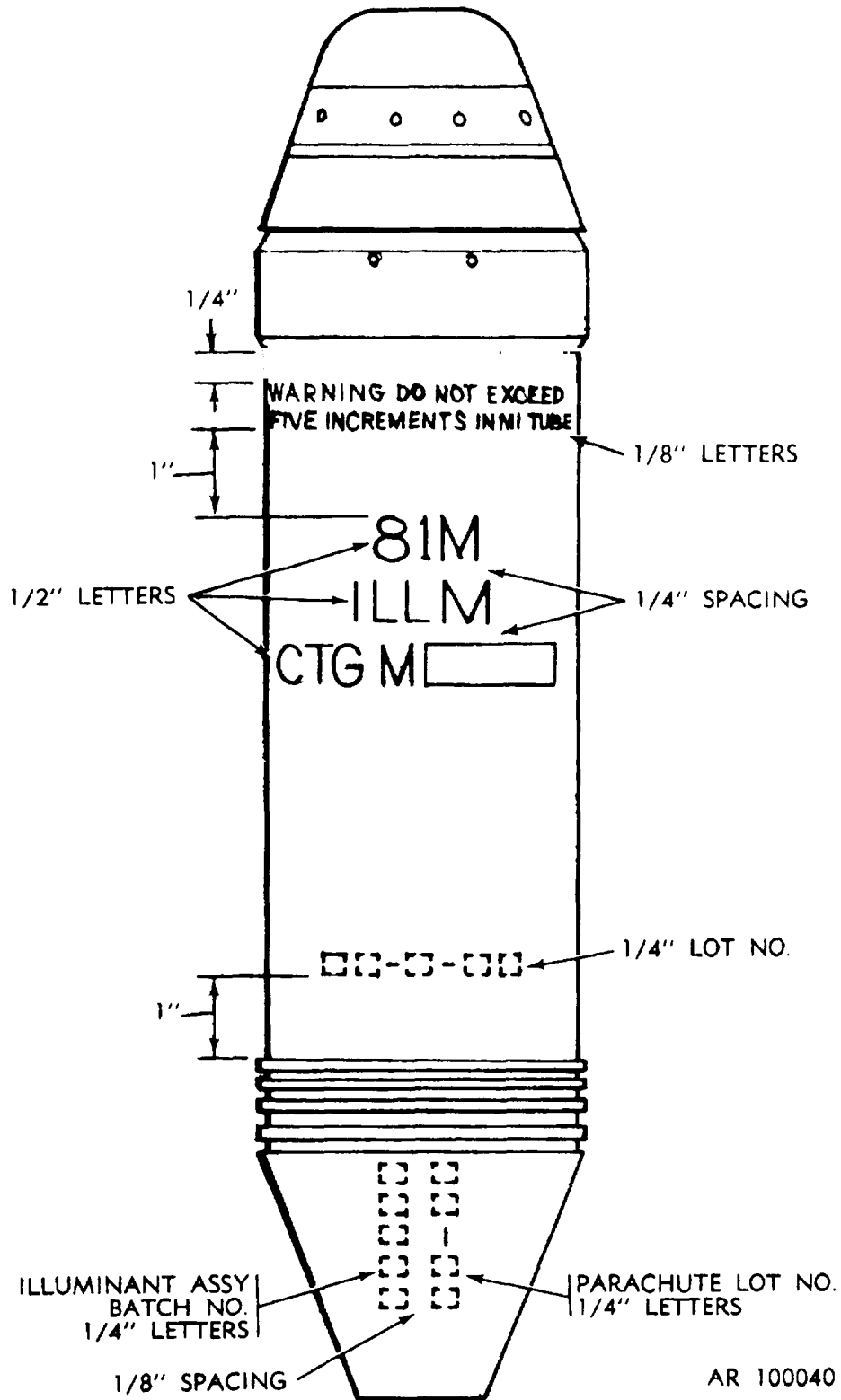
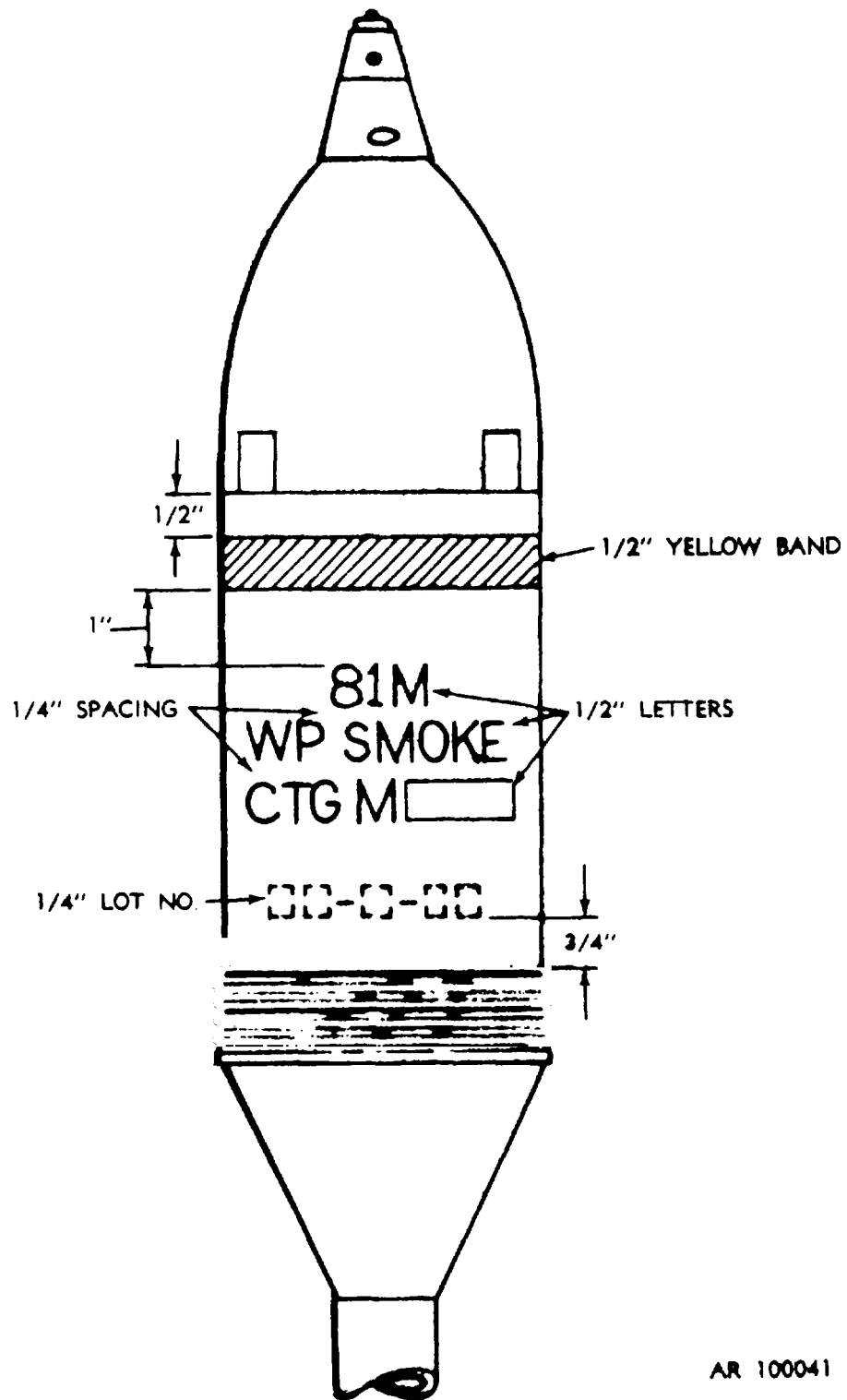

Figure E-25. Typical marking for 81mm mortar cartridges M301 series.



AR 100041

Figure E-26. Typical marking for 81mm mortar cartridges M57 series.

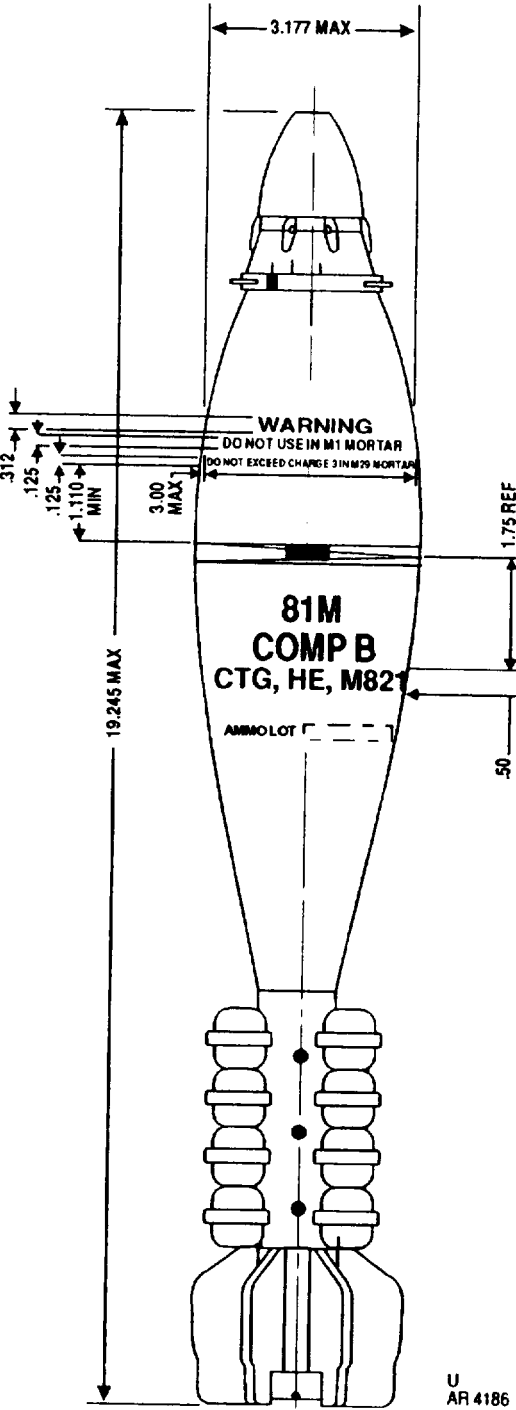

Figure E-27. Typical marking for 81mm mortar cartridge, M821 series.

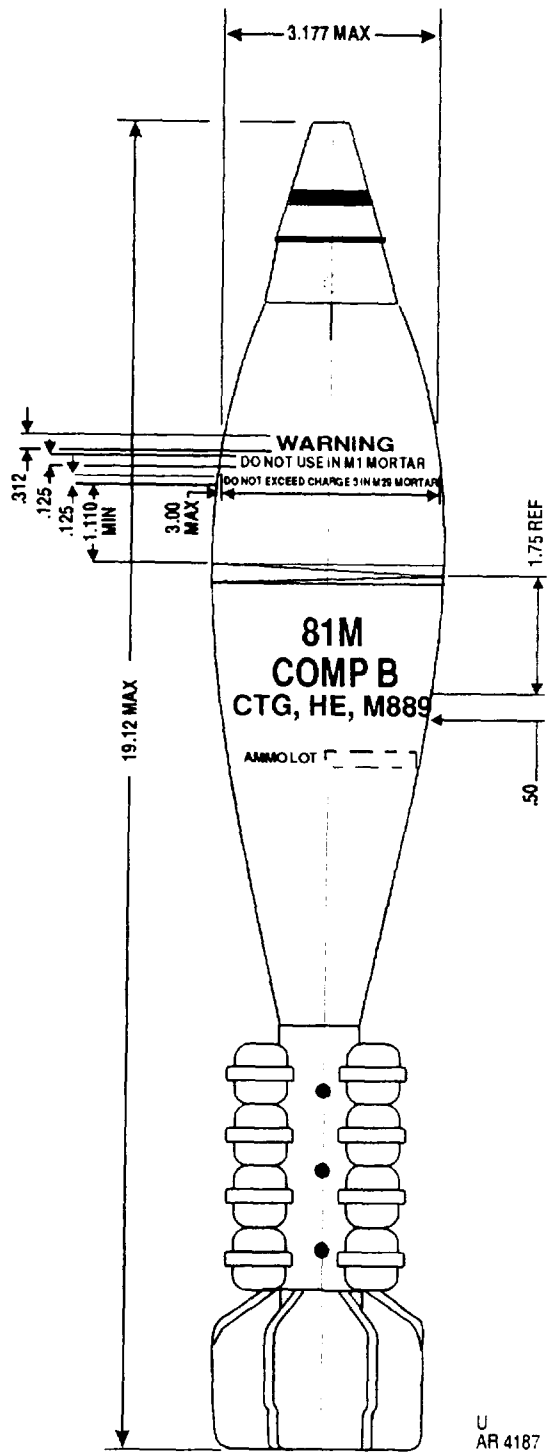
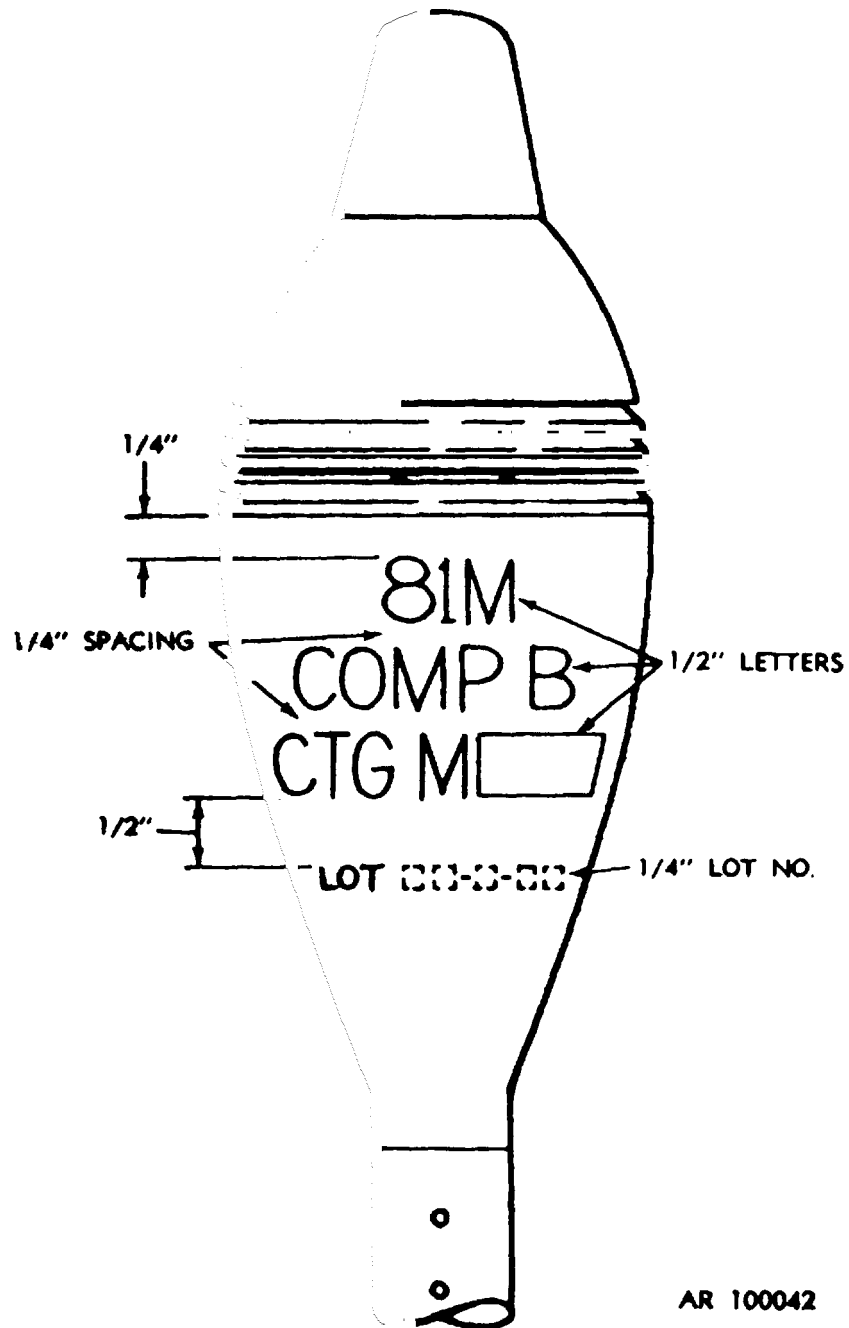

Figure E-28. Typical marking for 81mm mortar cartridge, M889 series



AR 100042

Figure E-29. Typical marking for 81mm mortar cartridges M23 series (HE and TP).

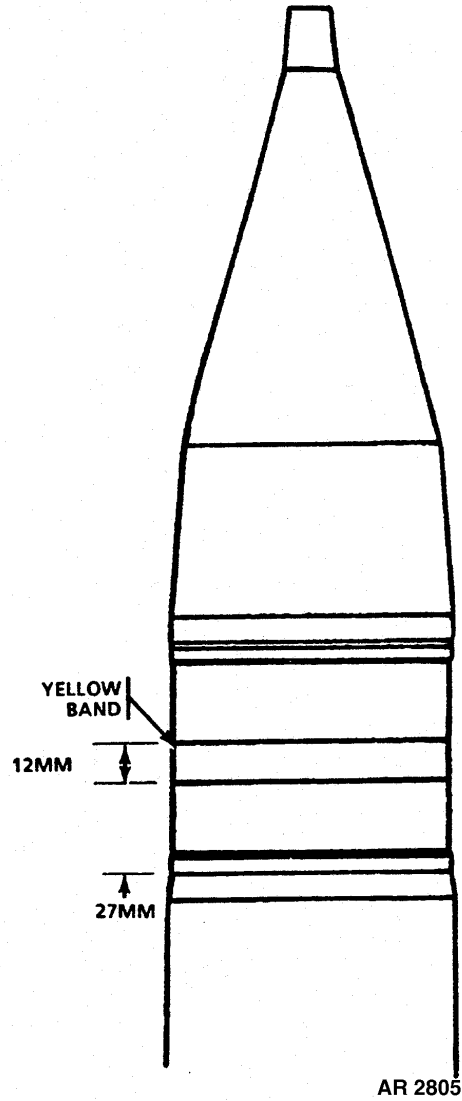

Figure E-30. Typical Marking for 84mm Launcher Cartridges M136 (AT4) and AT4 CS RS. |

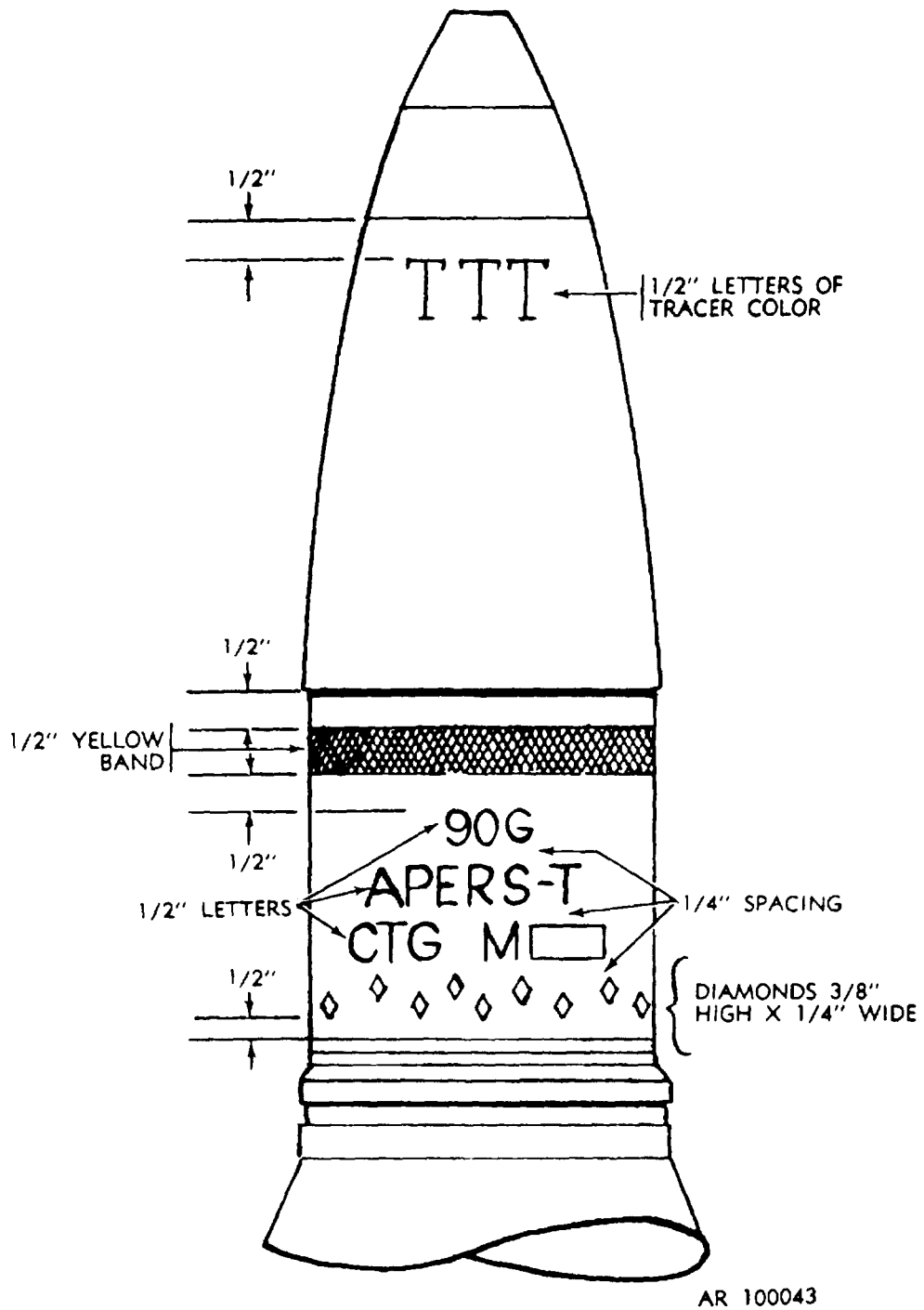

Figure E-31. Typical marking for 90mm gun cartridge M580.

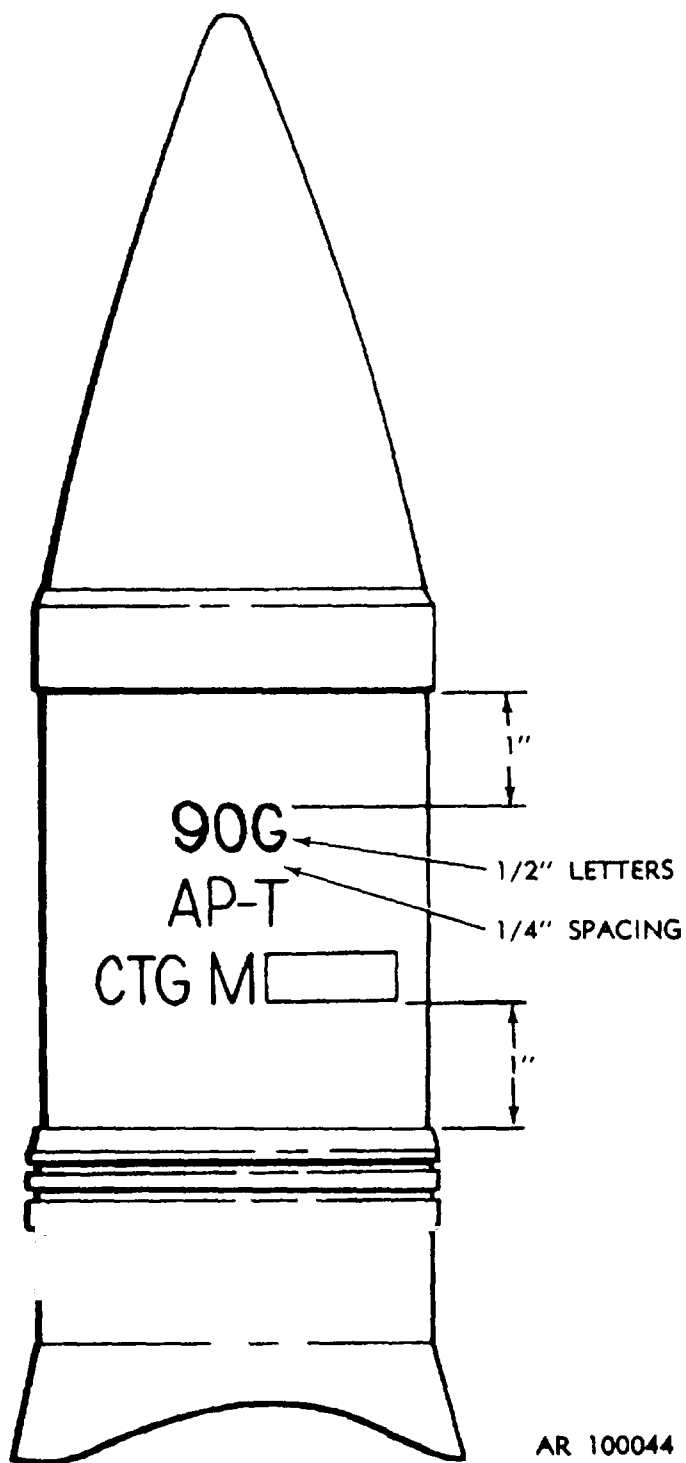
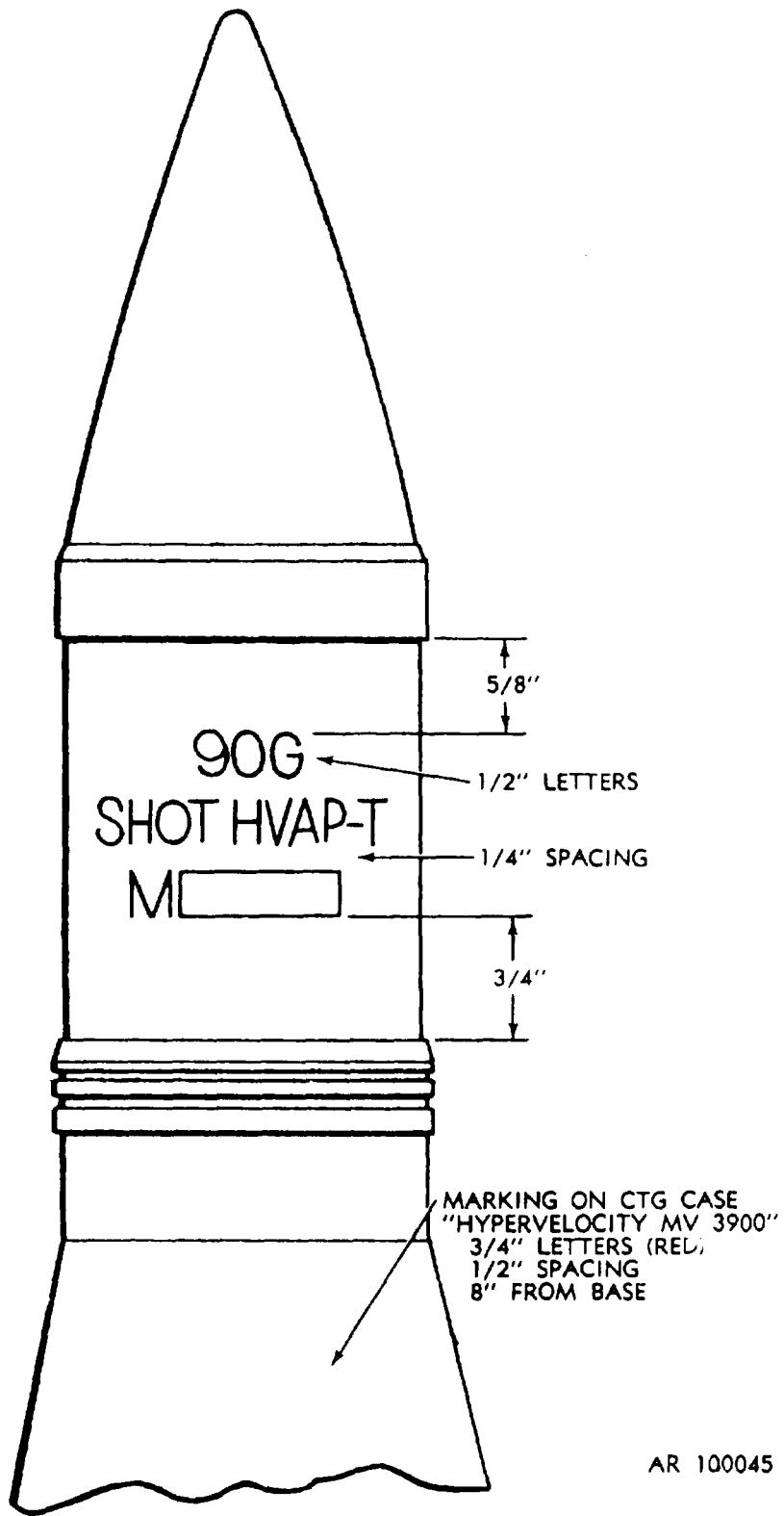

Figure E-32. Typical marking for 90mm gun cartridge M77, M318 and M353 series.



AR 100045

Figure E-33. Typical marking for 90mm gun cartridge M332A1.

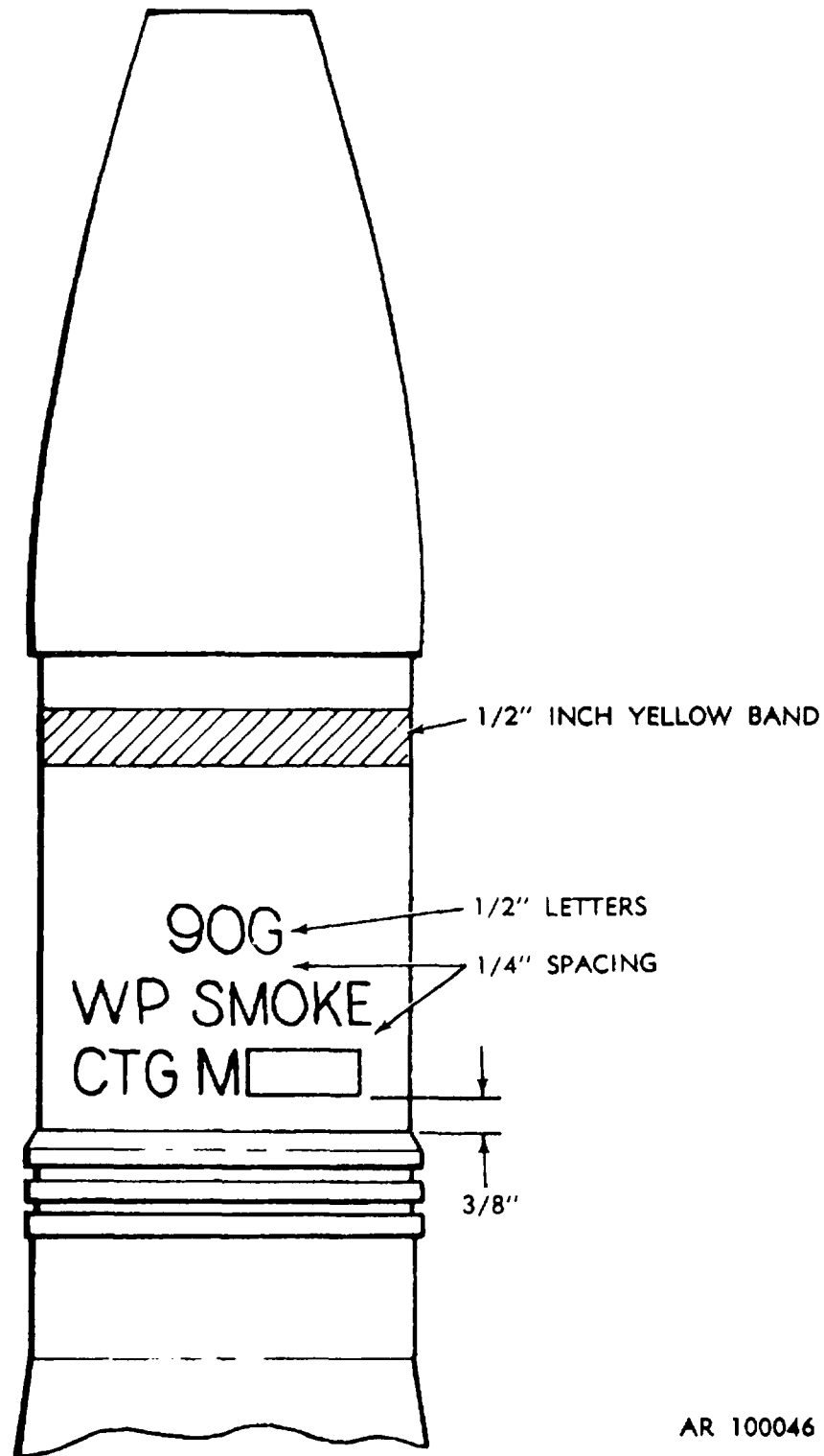

Figure E-34. Typical marking for 90mm gun cartridge M313 series.

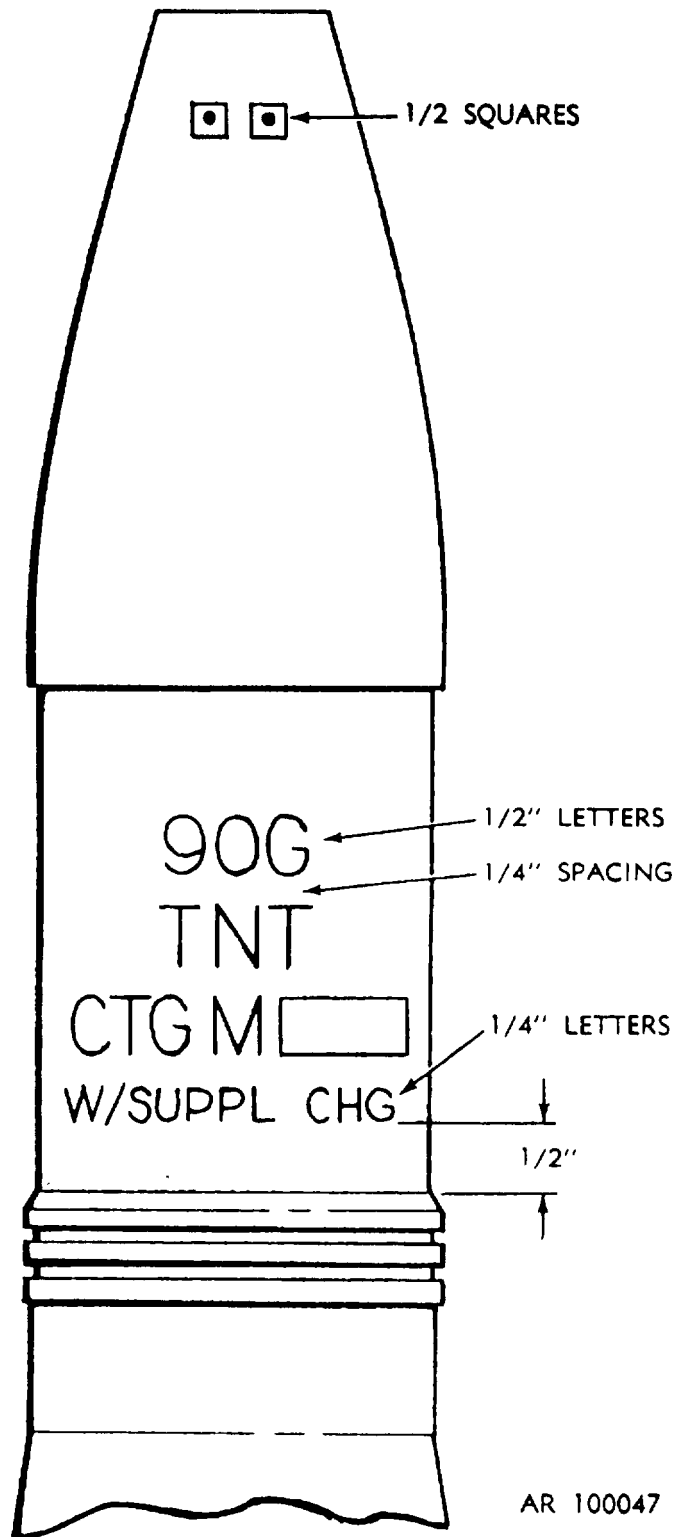

Figure E-35. Typical marking for 90mm gun cartridge M71 series.

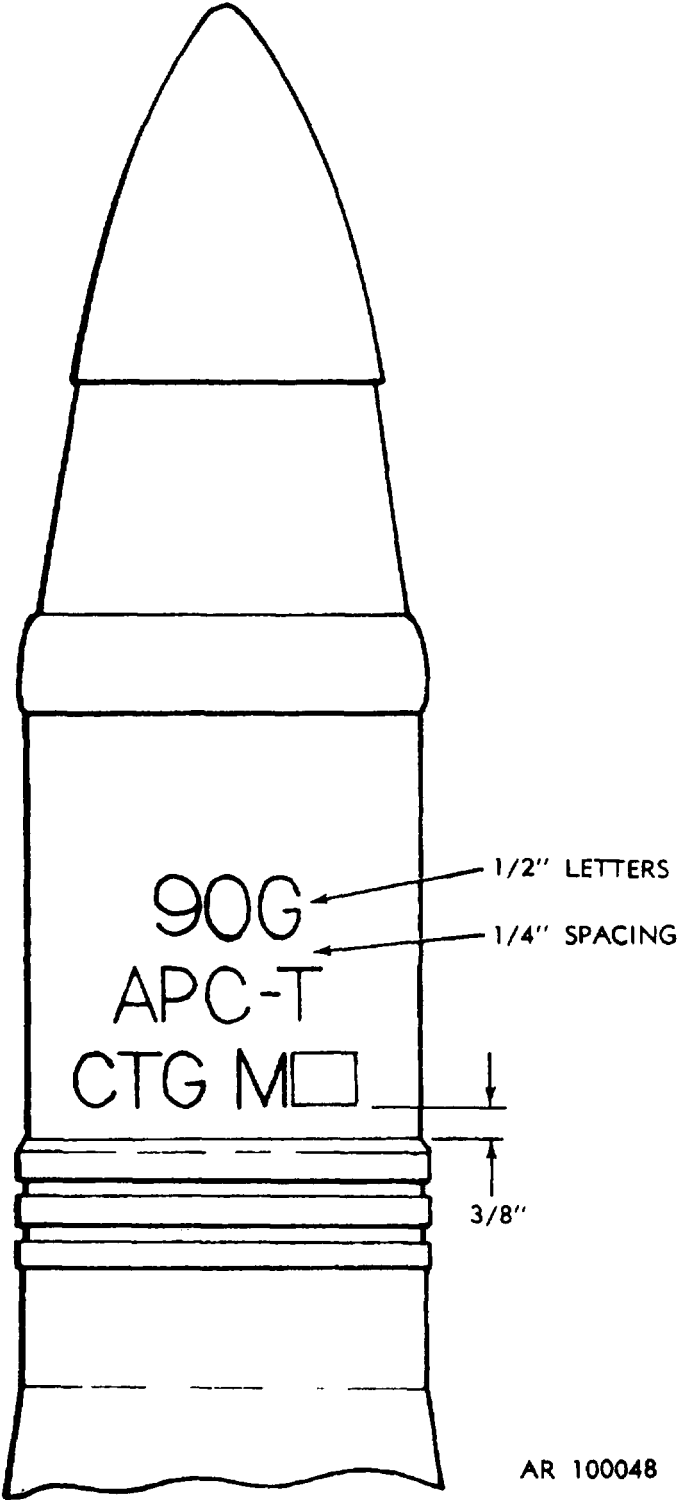

Figure E-36. Typical marking for 90mm gun cartridge M82.

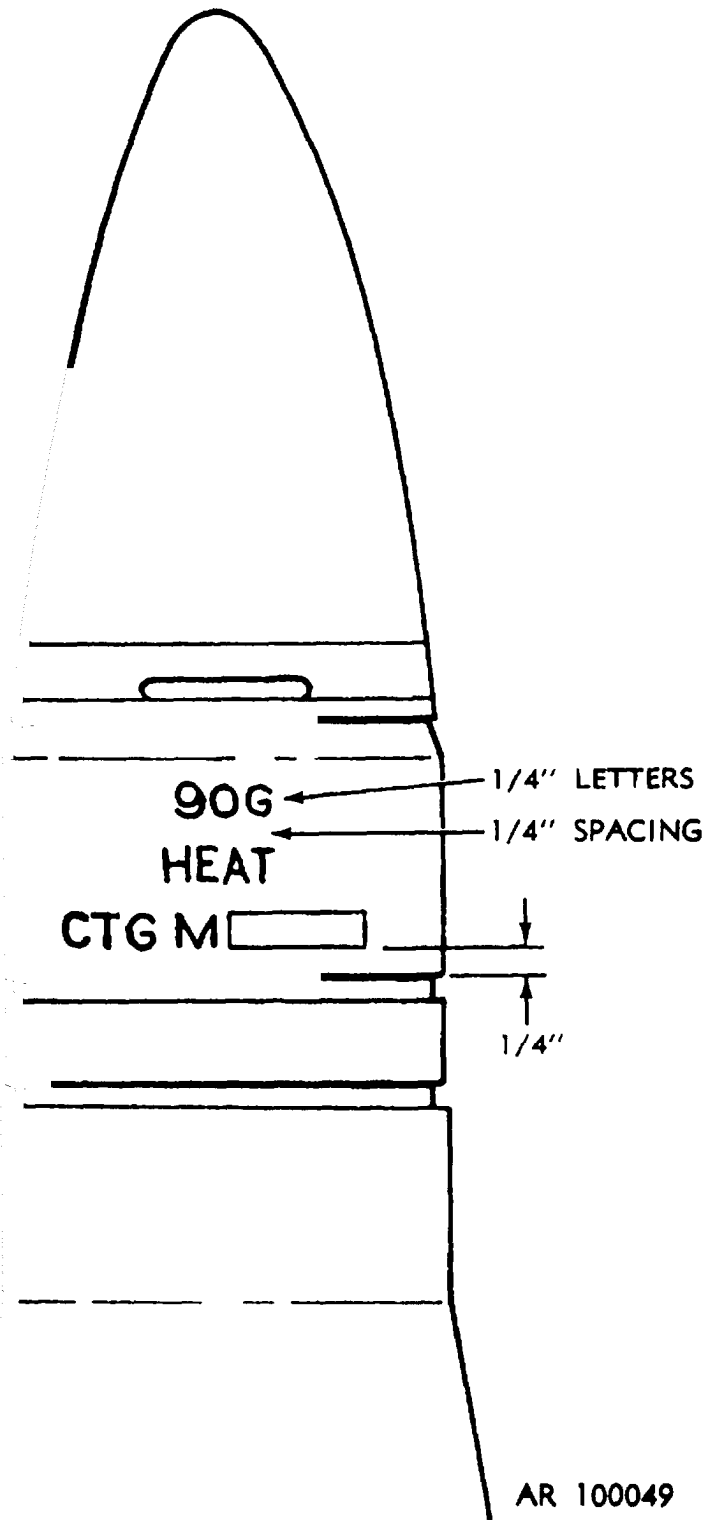

Figure E-37. Typical marking for 90mm gun cartridge M348A1.

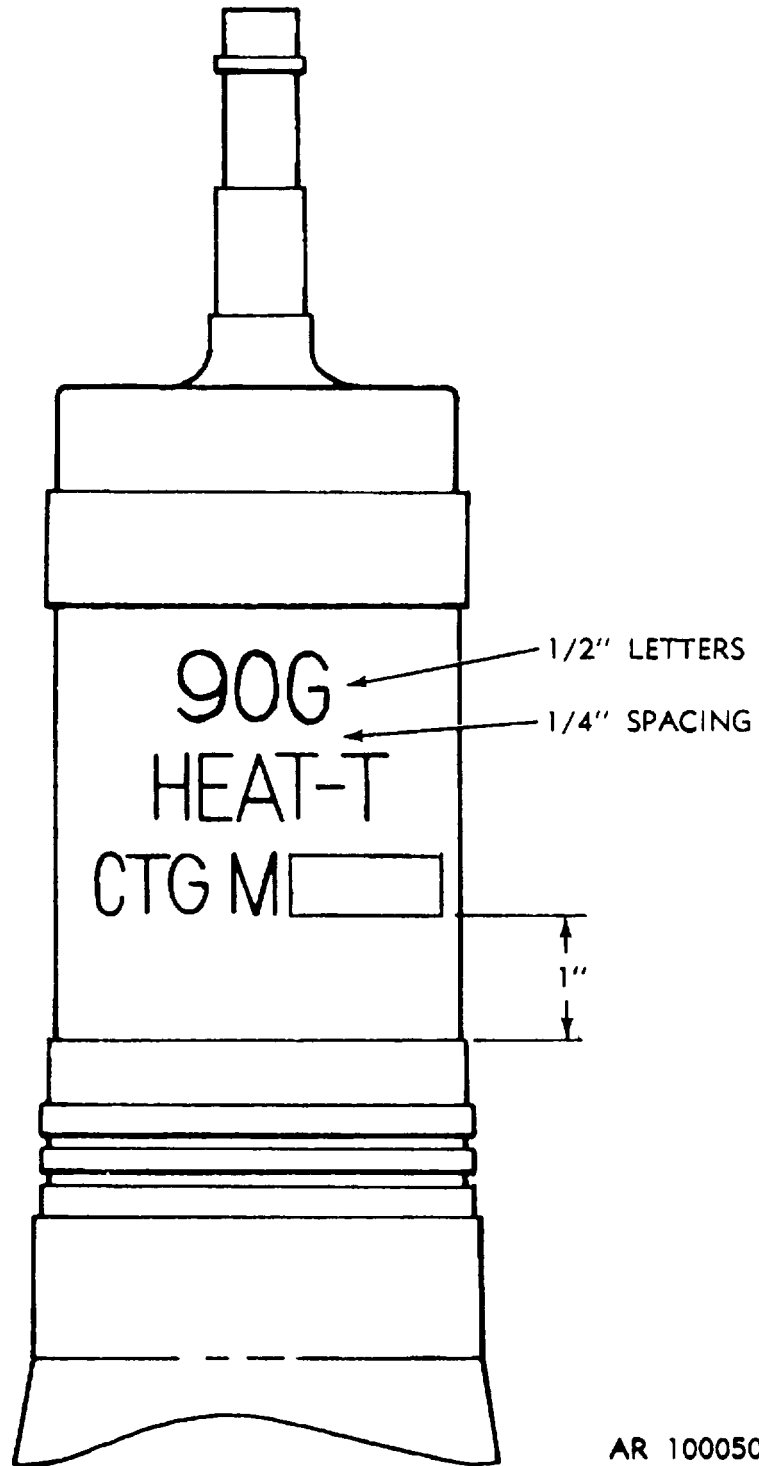

Figure E-38. Typical marking for 90mm gun cartridge M431 series.

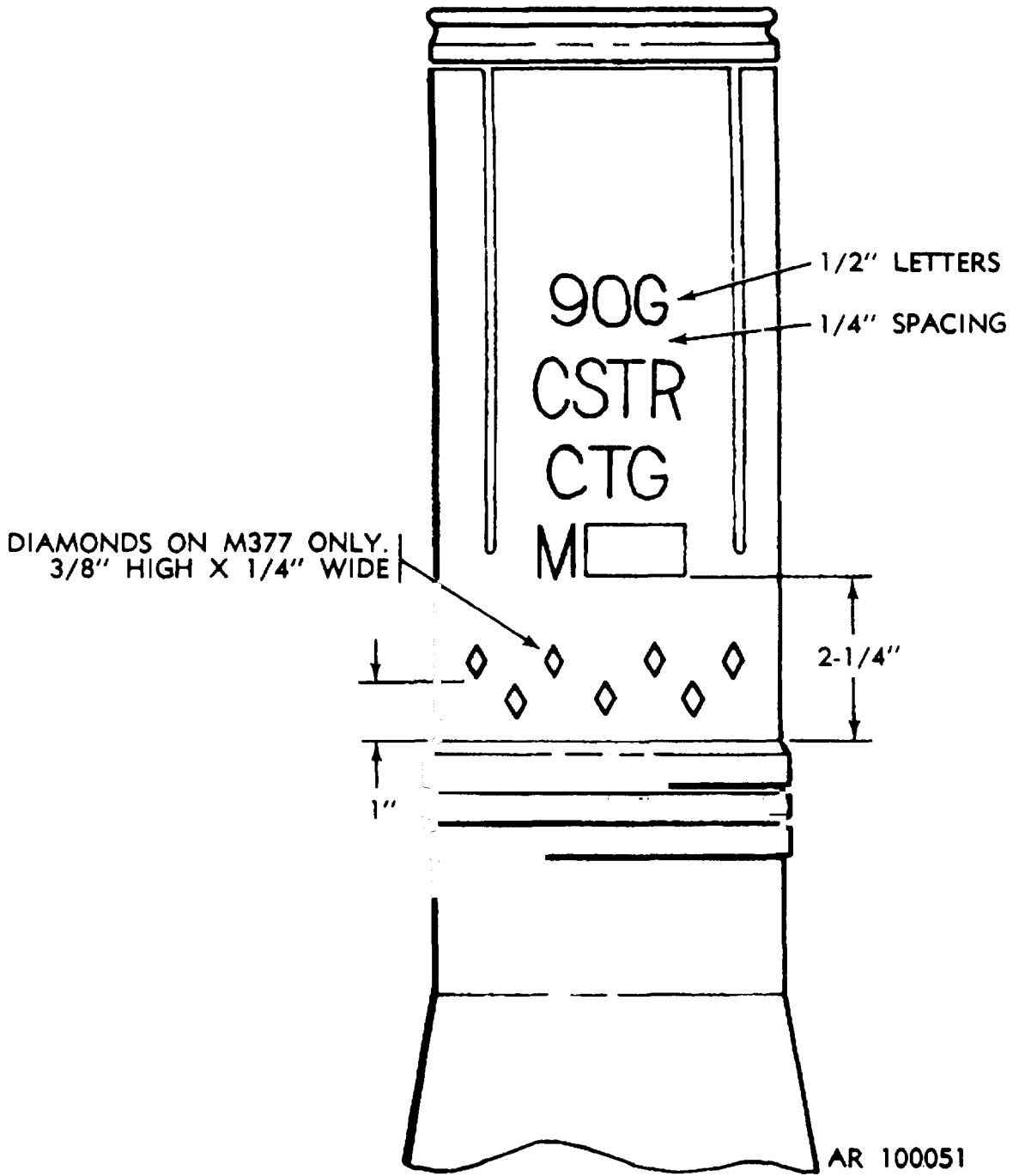

Figure E-39. Typical marking for 90mm gun cartridges M336 and M377.

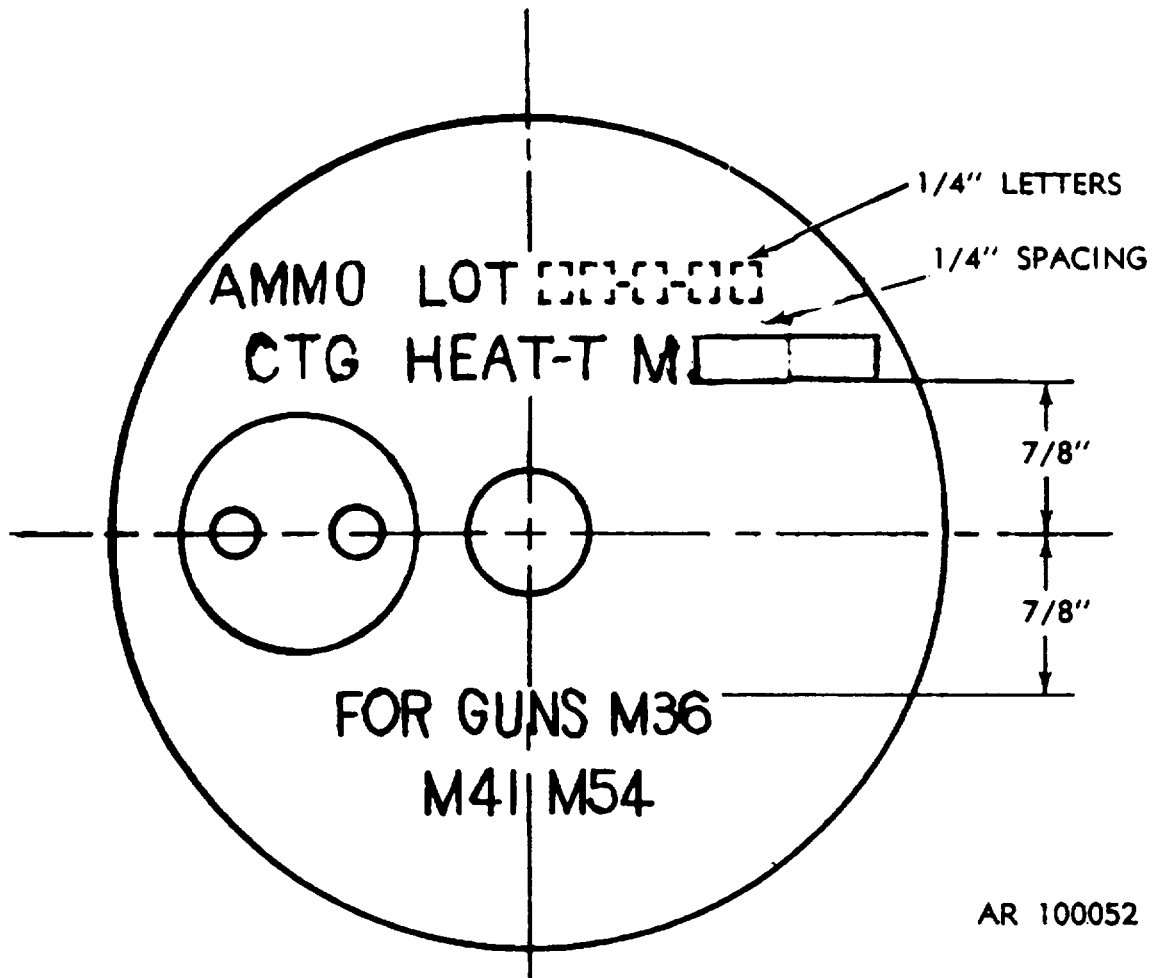
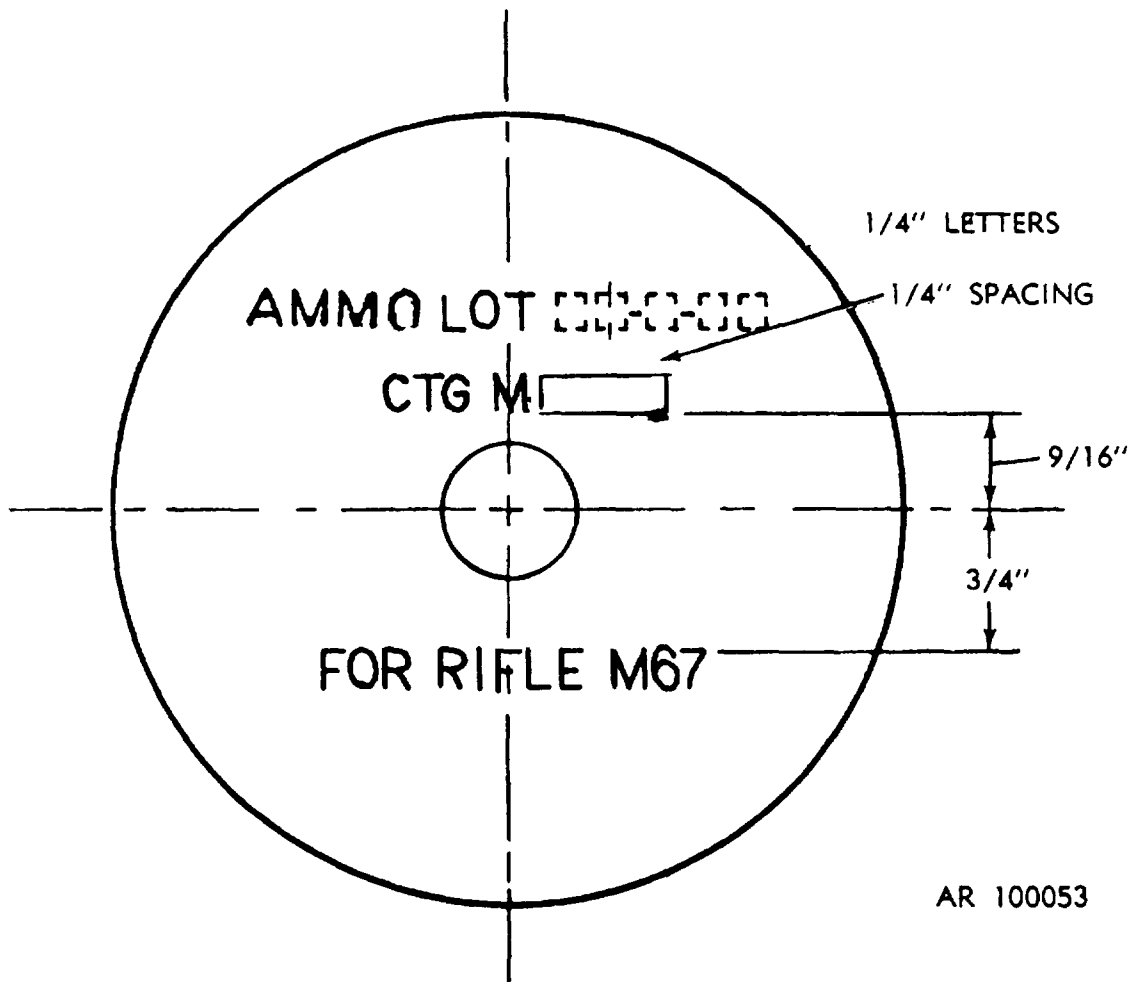

Figure E-40. Typical marking for cartridge case on 90mm gun cartridge M431A2.



AR 100053

Figure E-41. Typical marking for cartridge case on 90mm rifle cartridge M371A1.

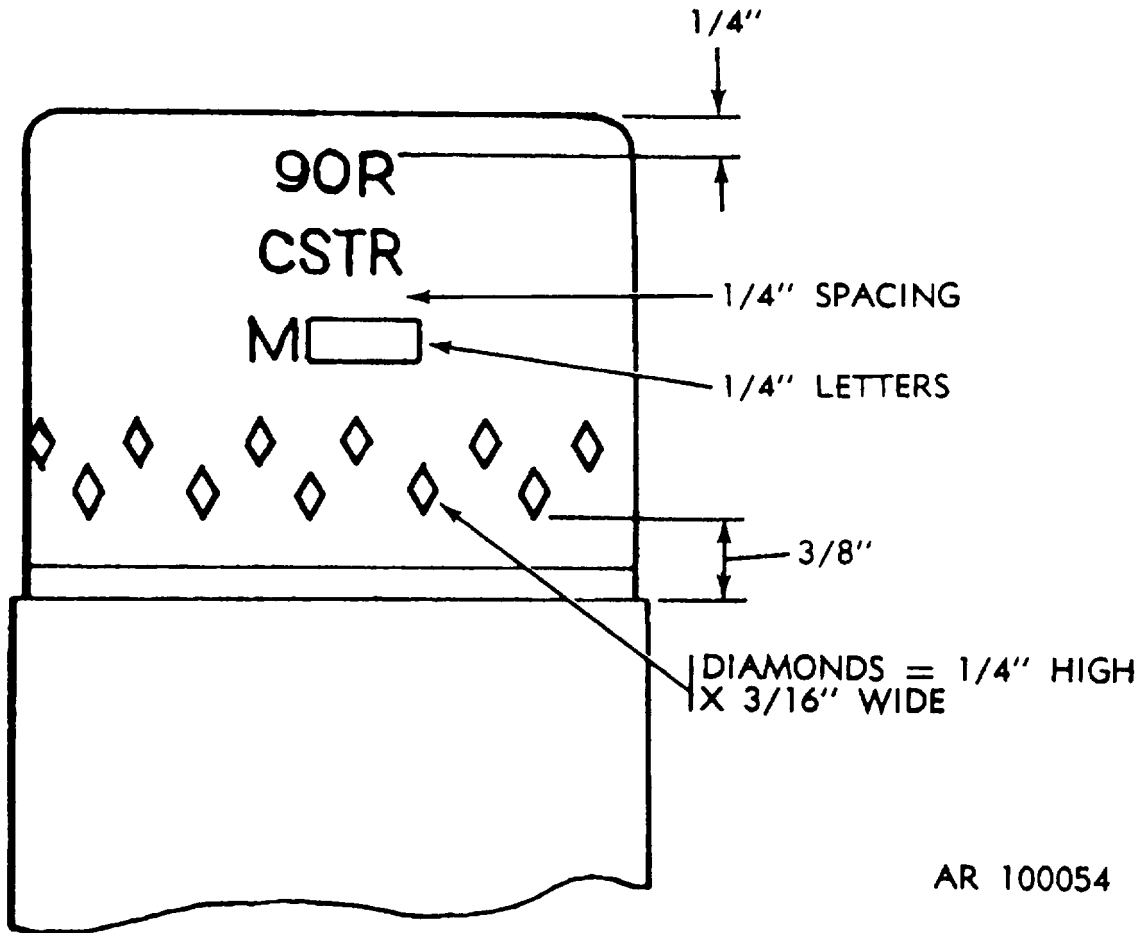

Figure E-42. Typical marking for 90mm rifle cartridge M590.

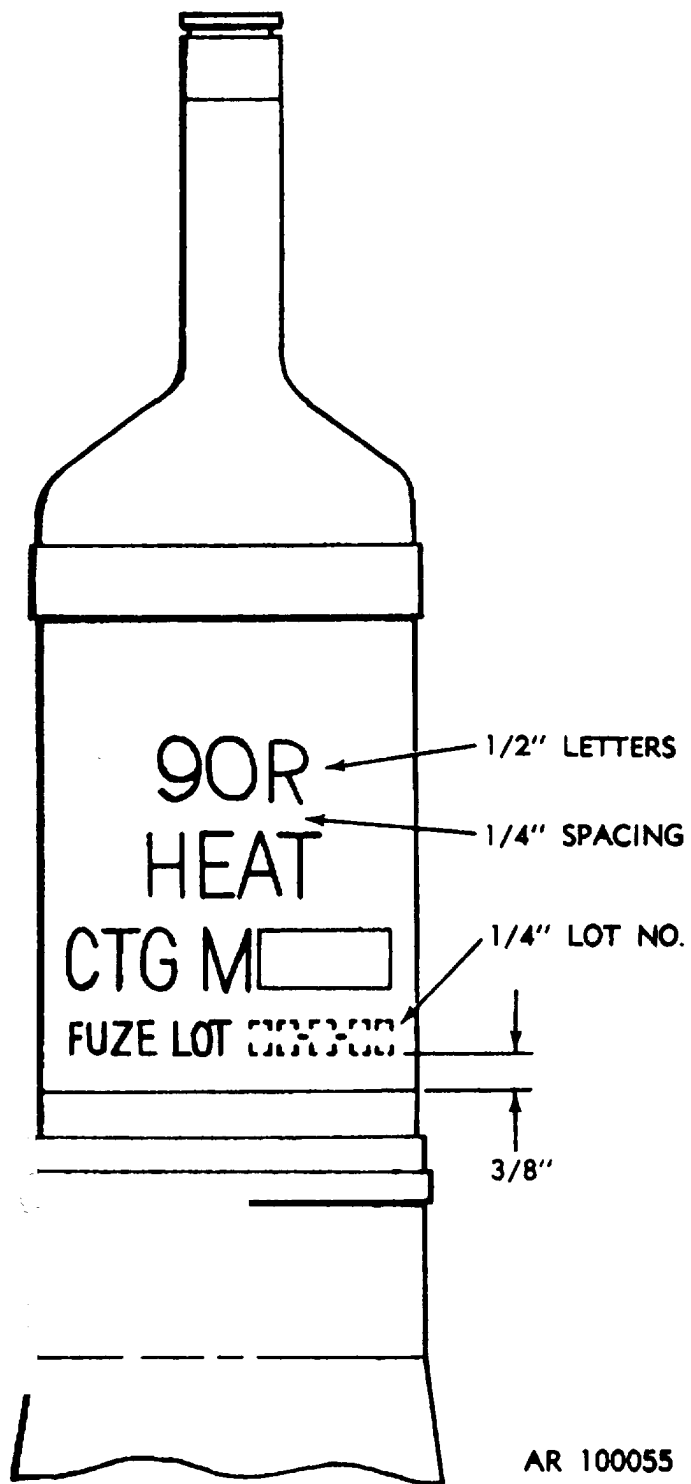

Figure E-43. Typical marking for 90mm rifle cartridge M371 series.

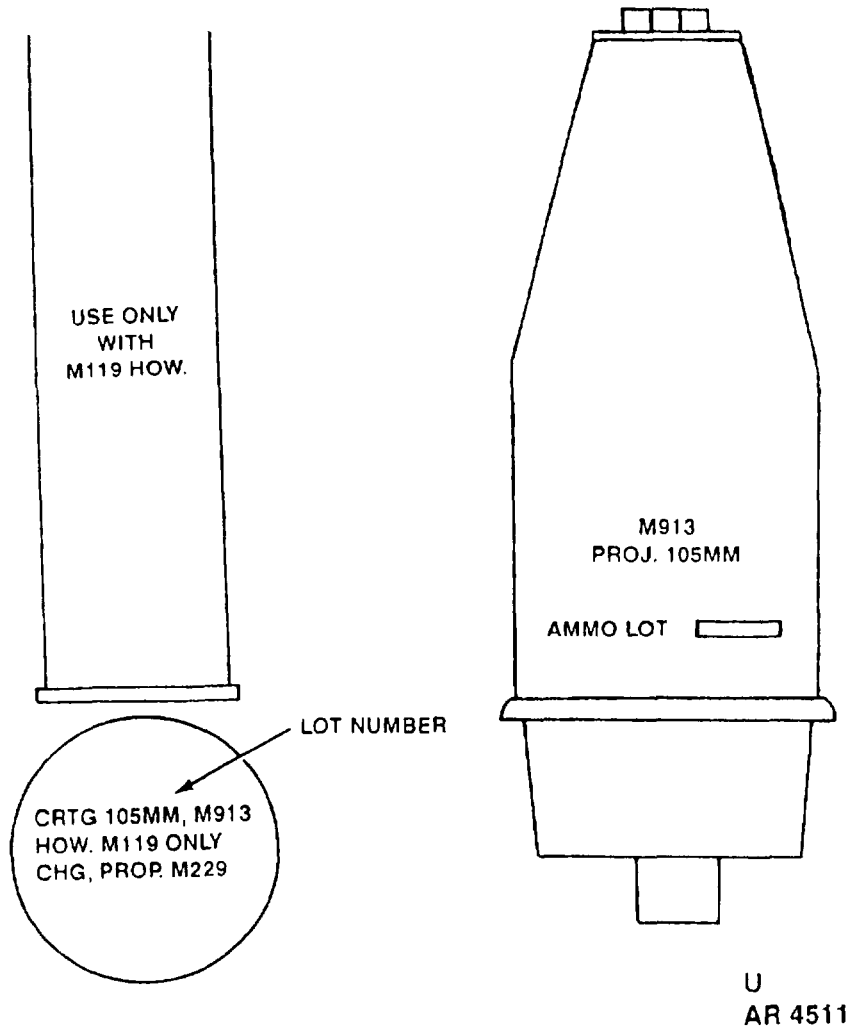
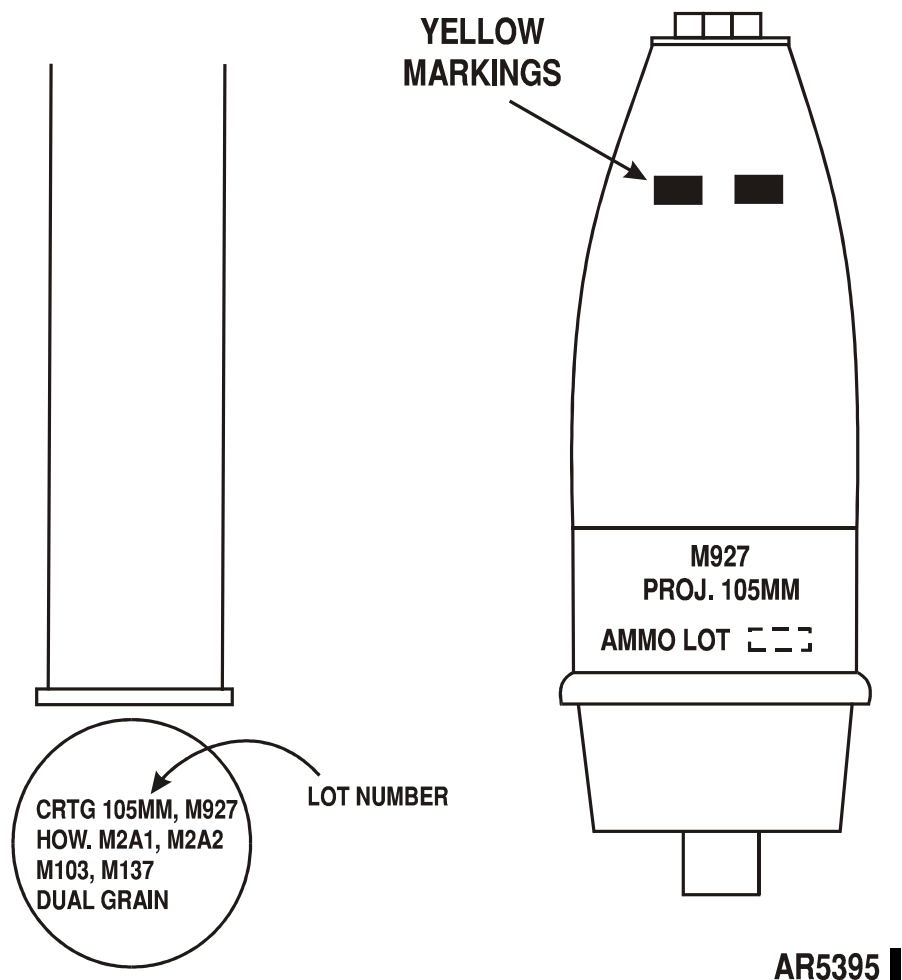

Figure E-44. Typical marking for 105mm howitzer cartridge M913



AR5395

Figure E-44.1. Typical Marking for 105mm Howitzer Cartridge M927.

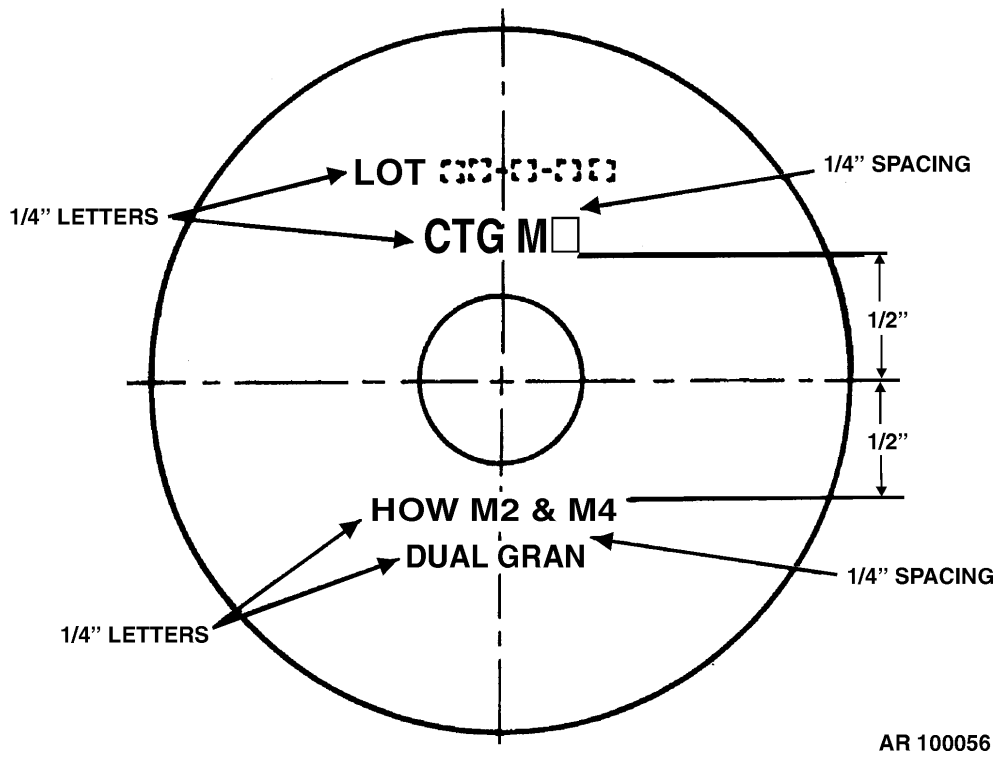

Figure E-45. Typical marking for Cartridge Case on 105mm Howitzer Round M1.

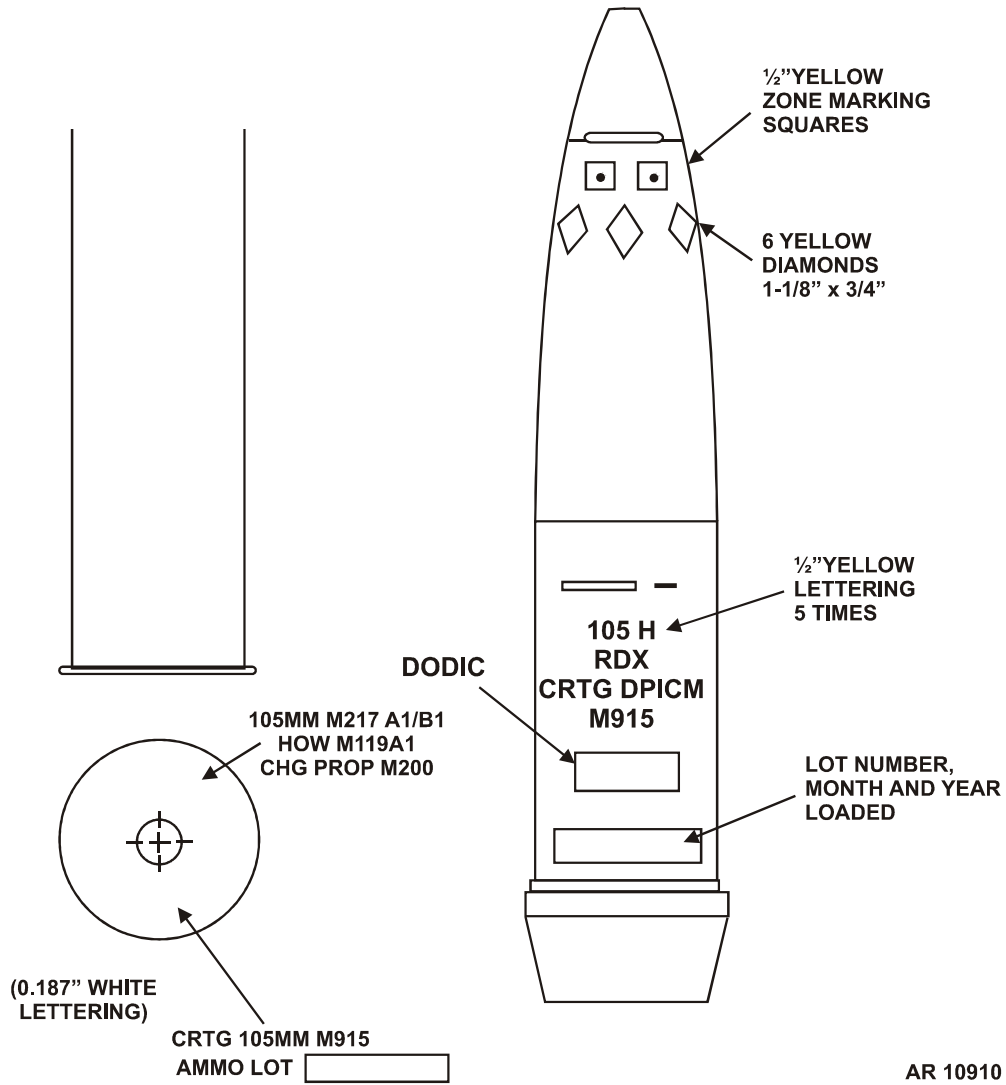

Figure E-45.1 - Typical Marking for 105mm Howitzer Cartridge M915.

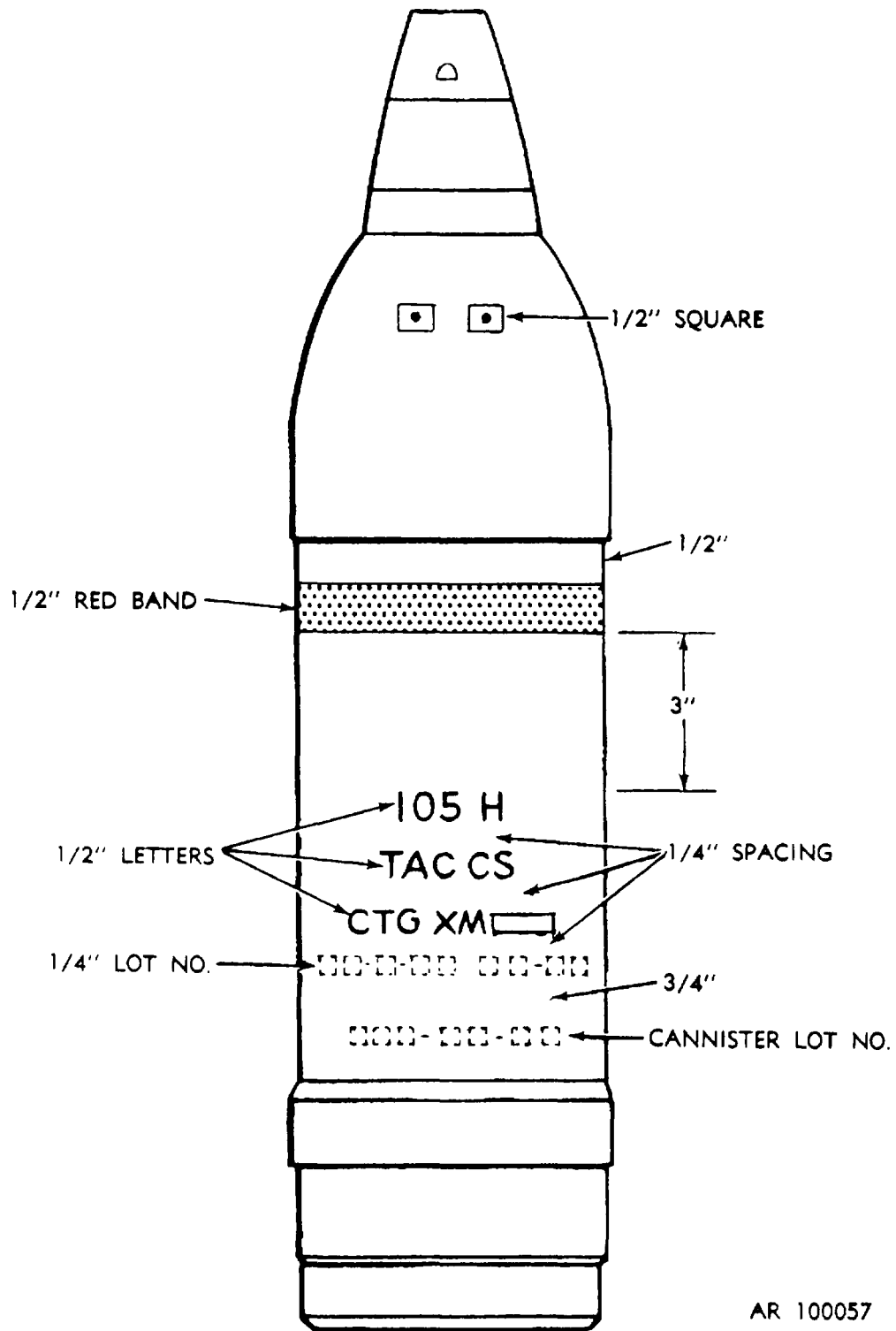

Figure E-46. Typical marking for projectile of 105mm howitzer cartridge XM629.

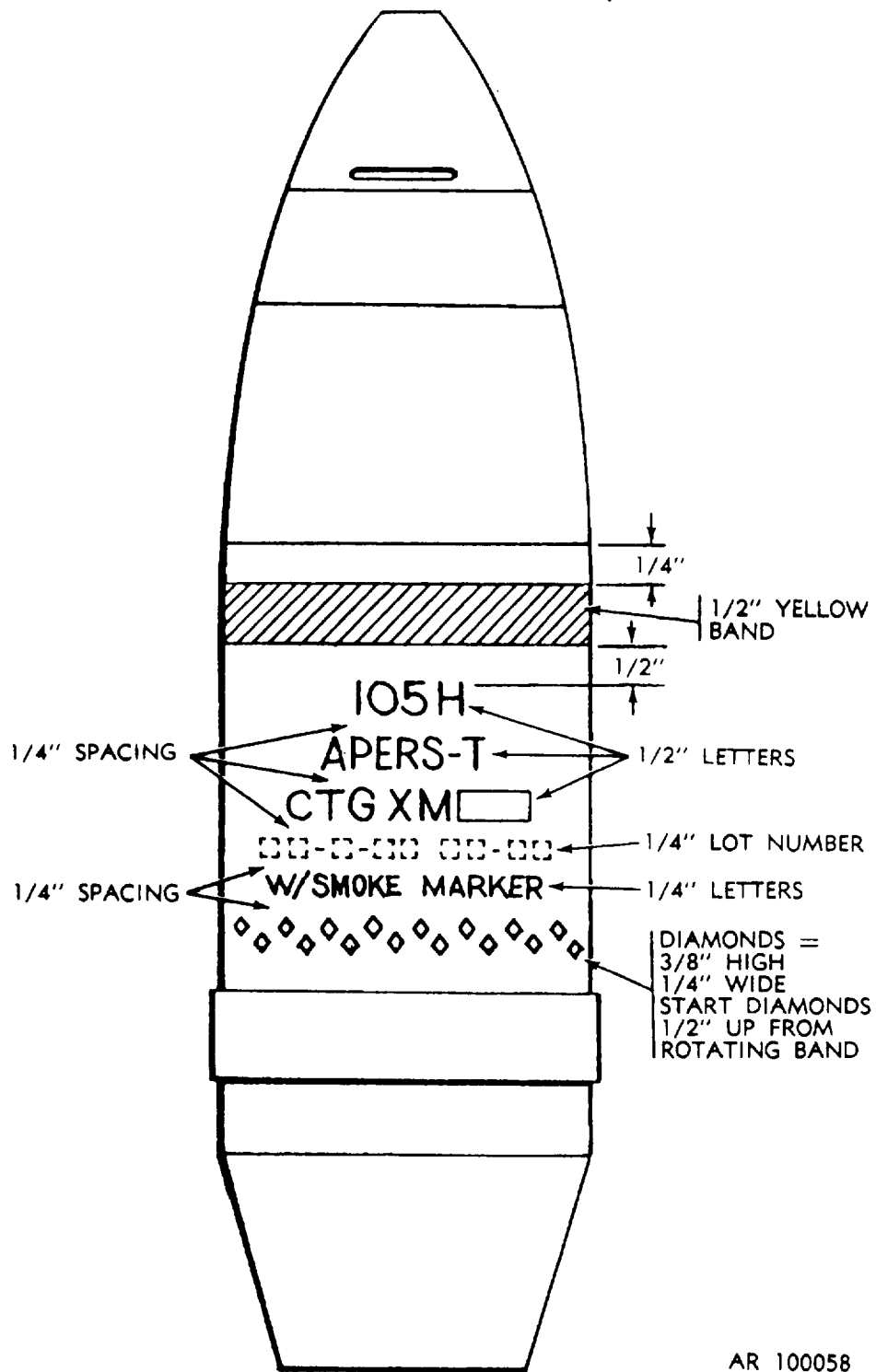
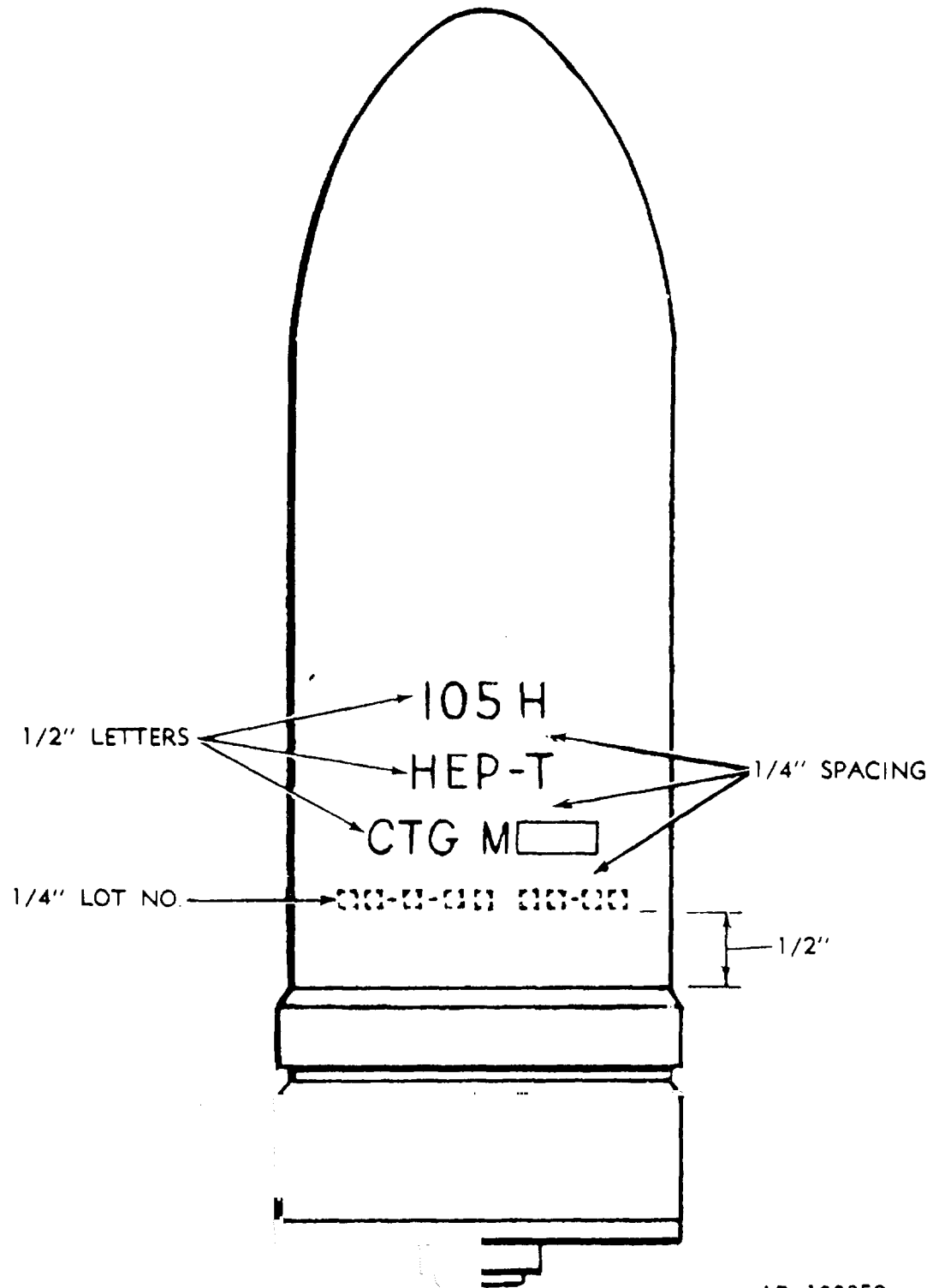

Figure E-47. Typical marking for projectile of 105mm howitzer cartridge M546.



AR 100059

Figure E-48. Typical marking for projectile of 105mm howitzer cartridge M327.

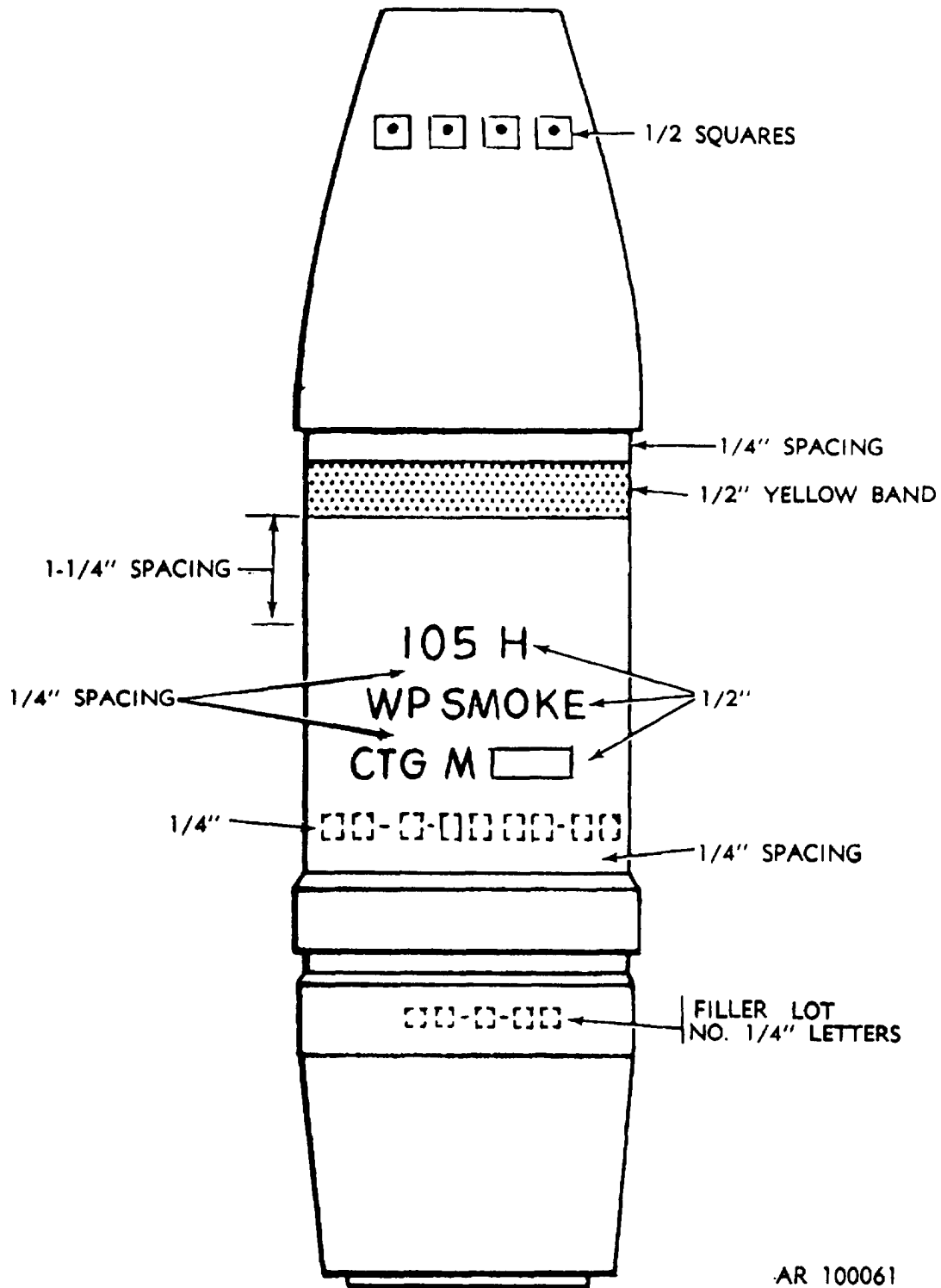

Figure E-49. Typical marking for projectile of 105mm howitzer cartridge M60 series and M84 series.

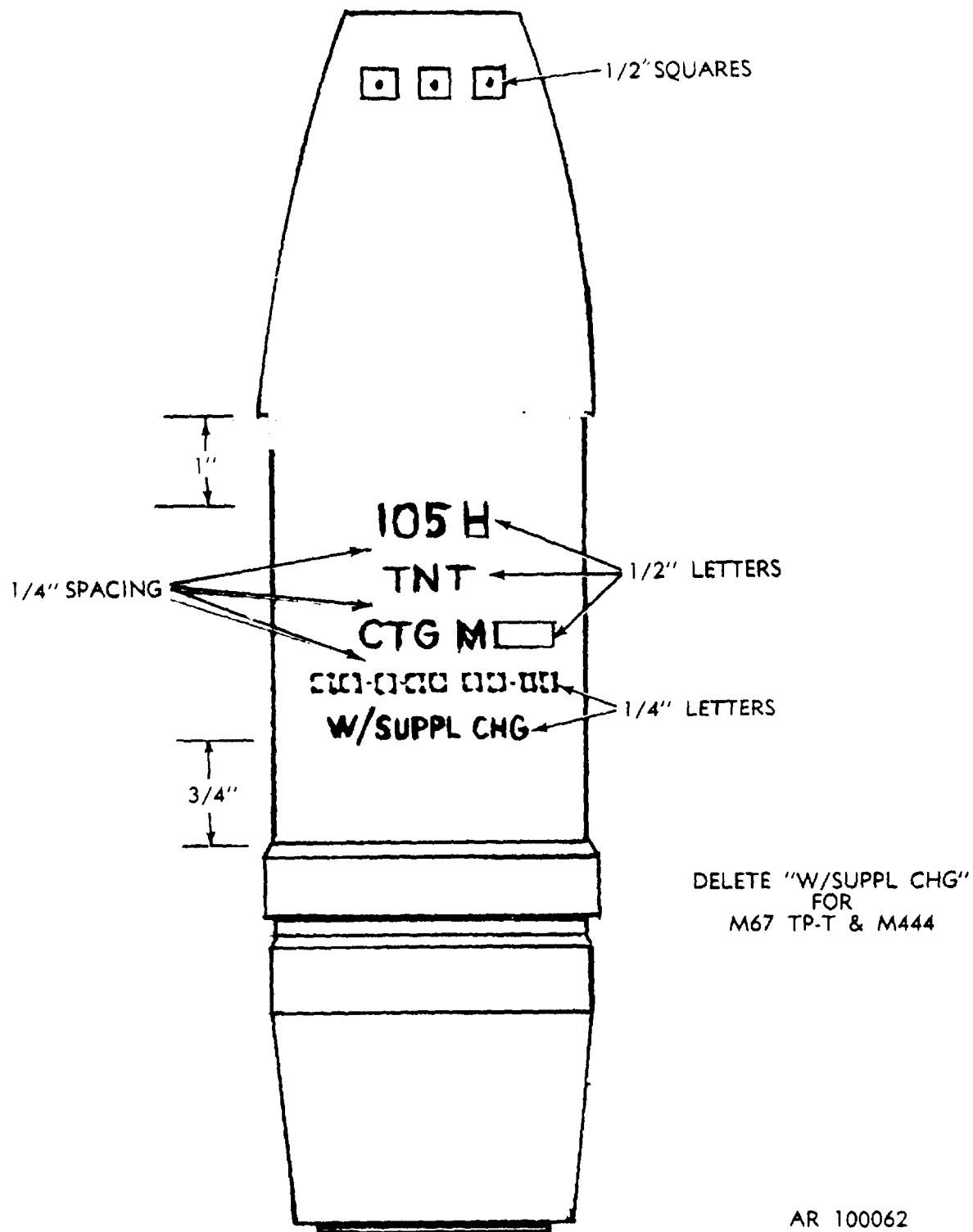
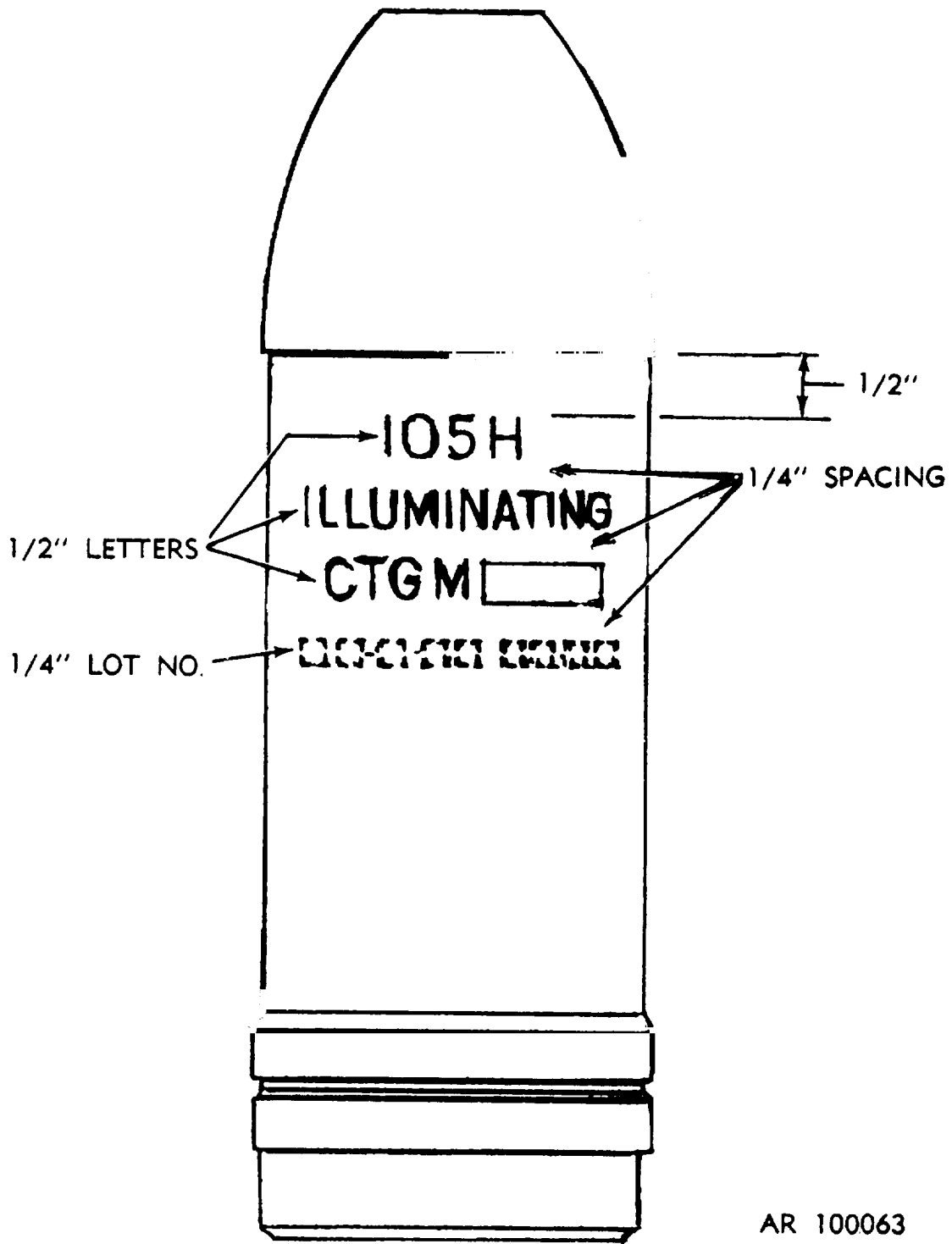

Figure E-50. Typical marking for projectiles of 105mm howitzer cartridges M1, M67, M413 and M444.



AR 100063

Figure E-51. Typical marking for projectiles of 105mm howitzer cartridge M314 series.

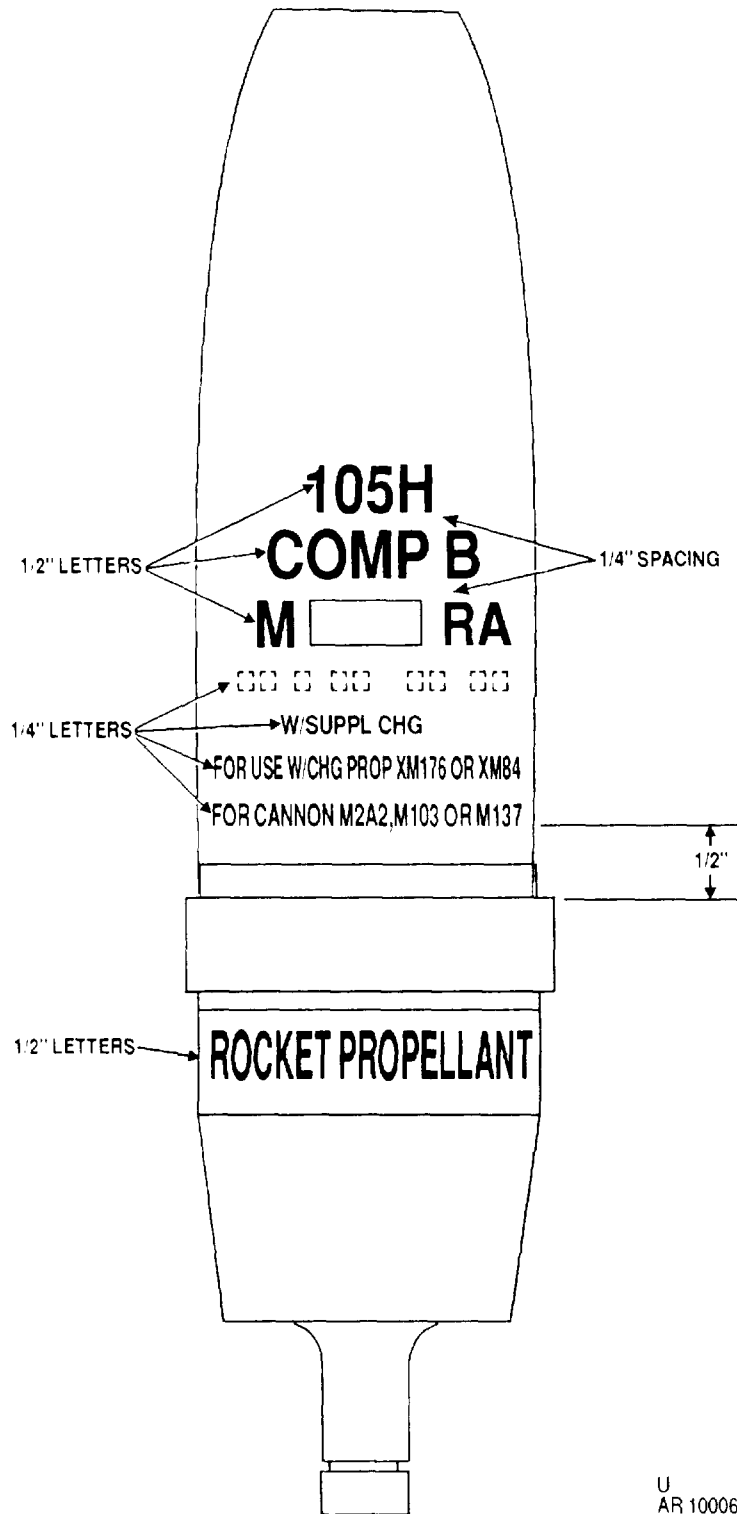
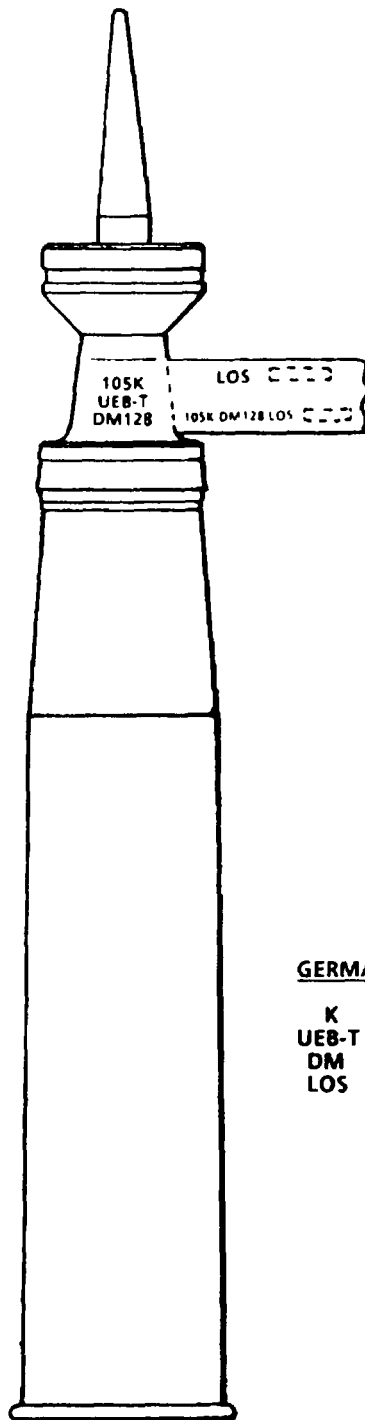

Figure E-52. Typical marking for projectile of 105mm howitzer cartridge M548.



GERMAN

K
UEB-T
DM
LOS

ENGLISH(MEANING)

CANNON
TPCSDS-T
GERMAN MODEL
LOT

ARD 2769

Figure E-53. Typical marking for 105mm gun cartridge, DM128.

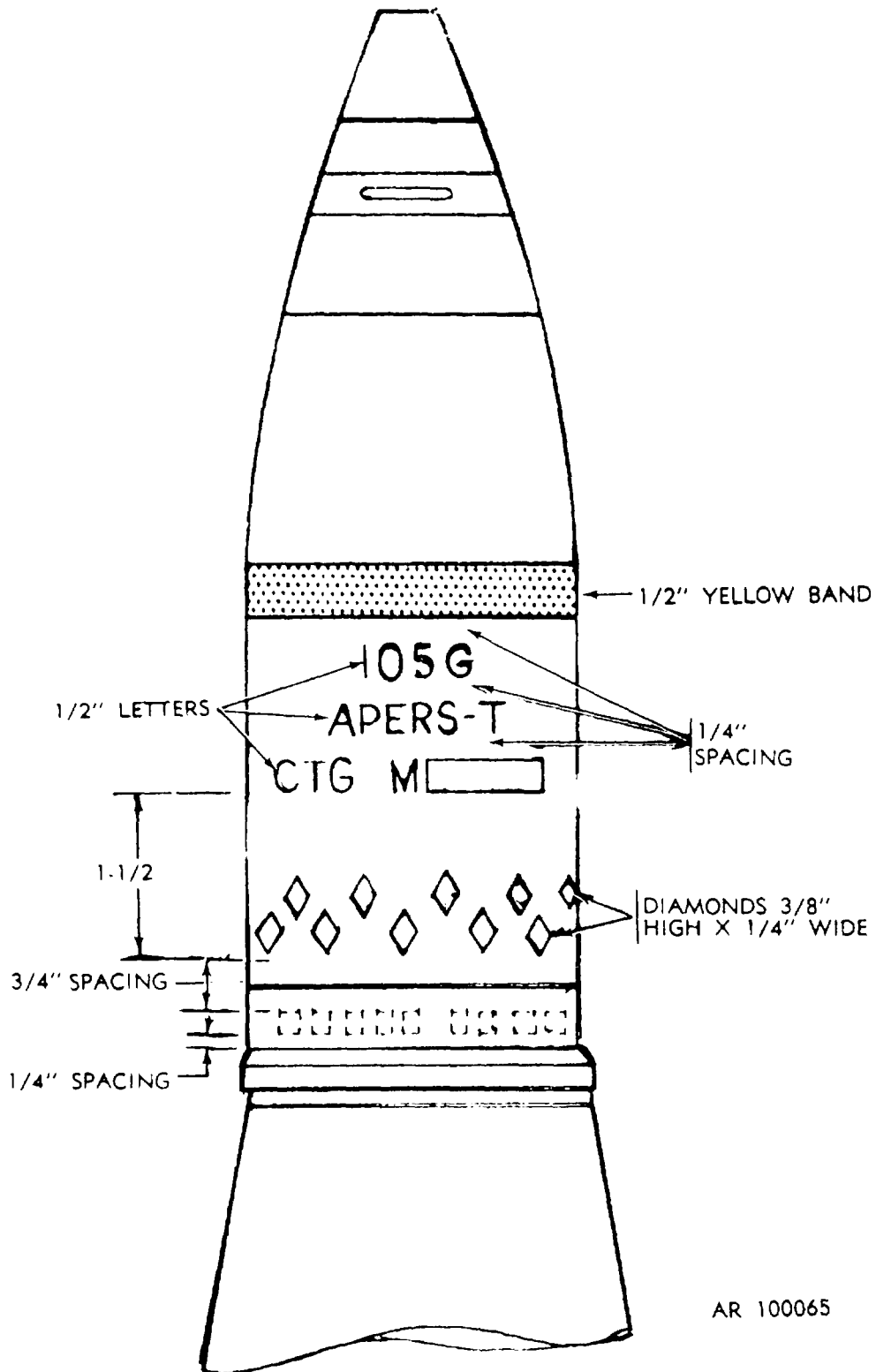

AR 10065

Figure E-54. Typical marking for 105mm gun cartridge XM494E3.

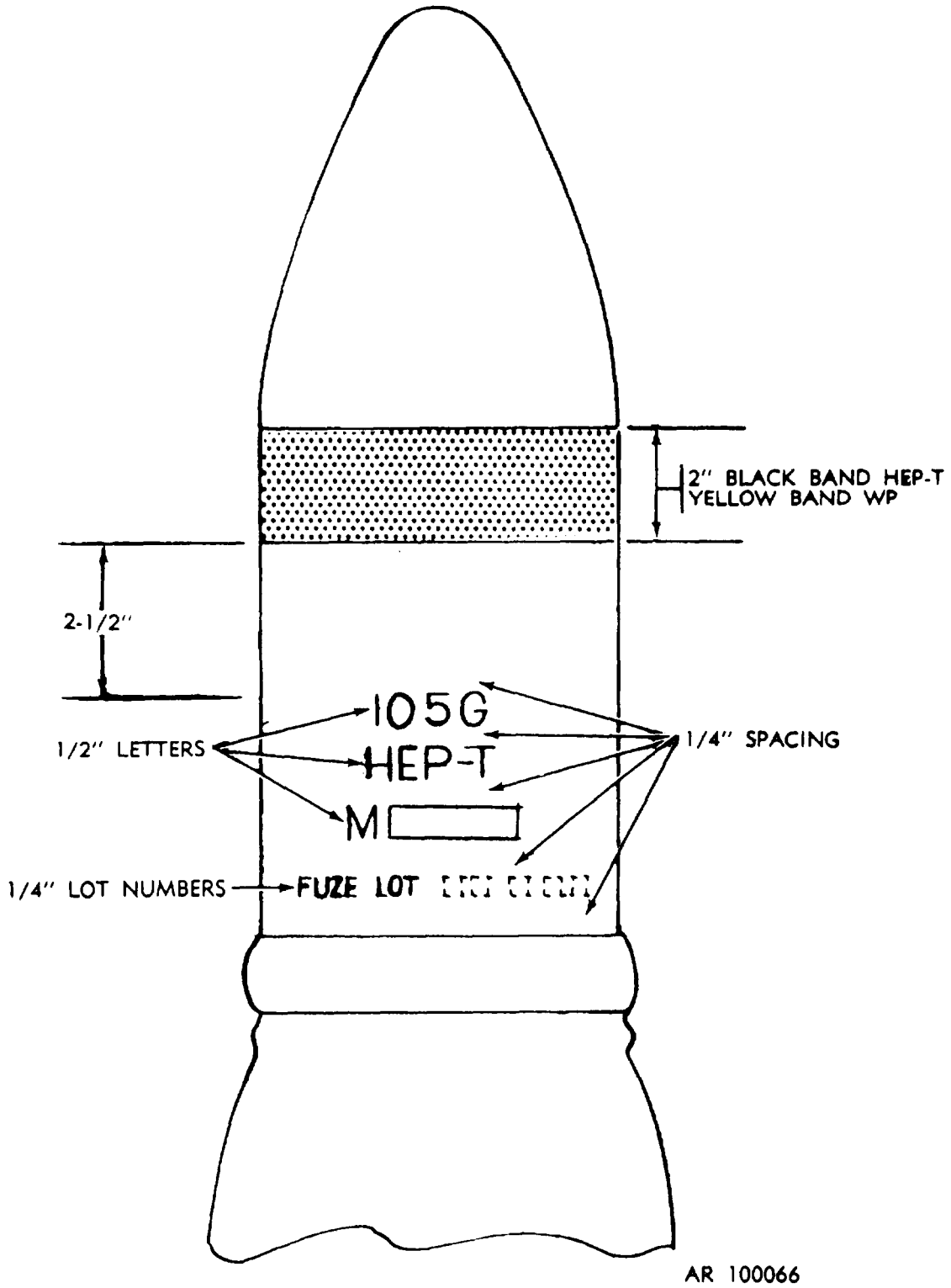

Figure E-55. Typical marking for 105mm gun cartridge M393 series, M416 and M417.

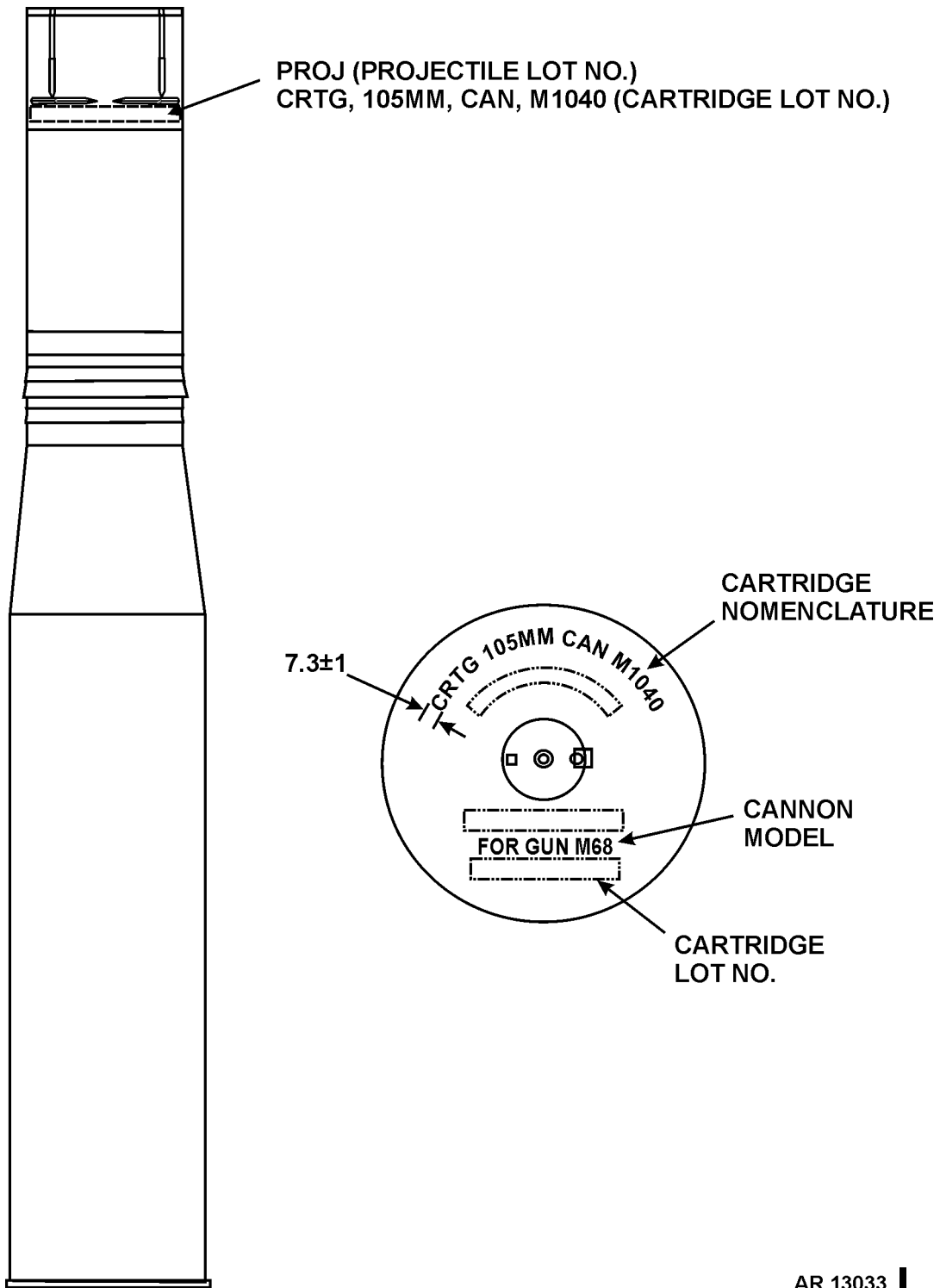
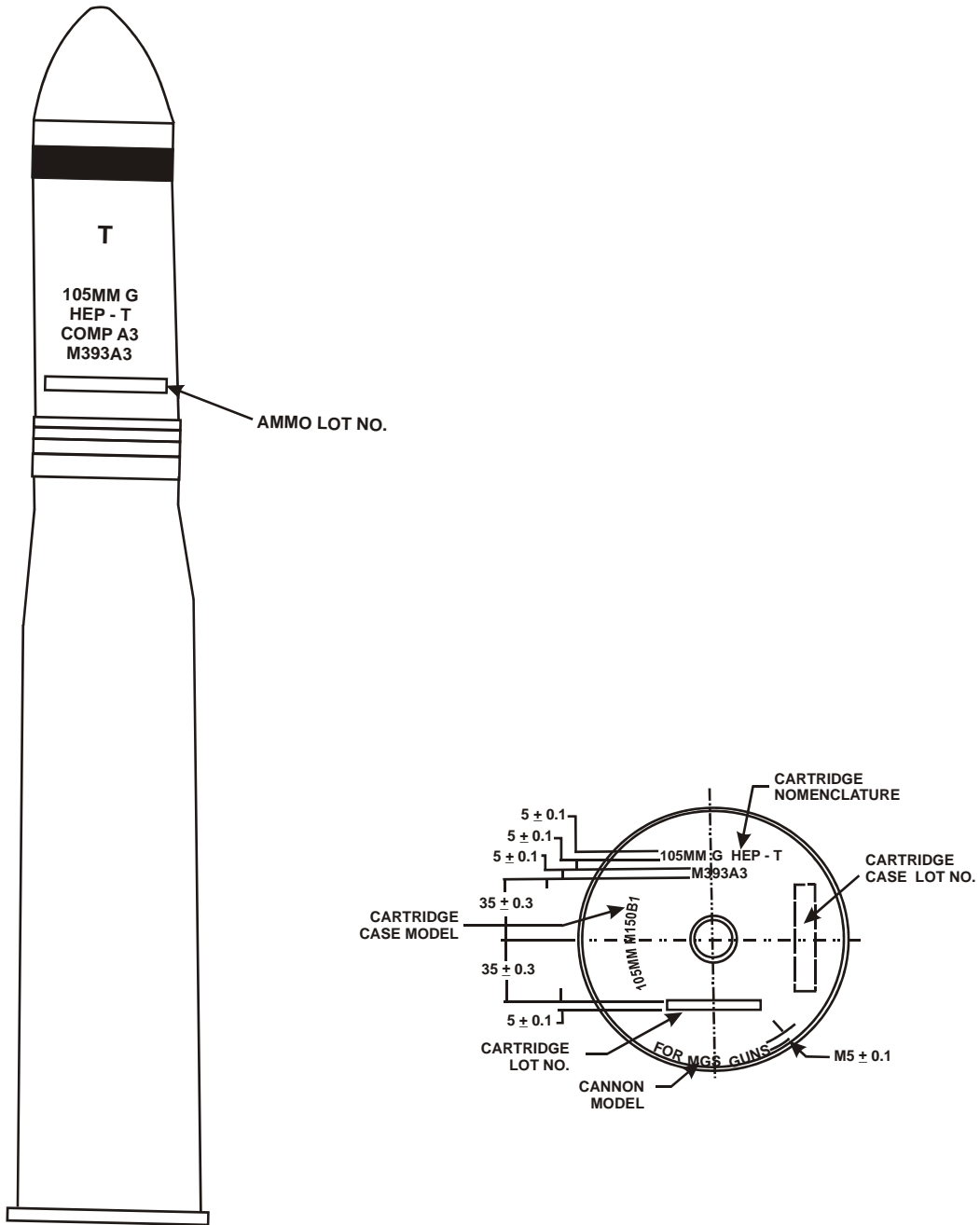
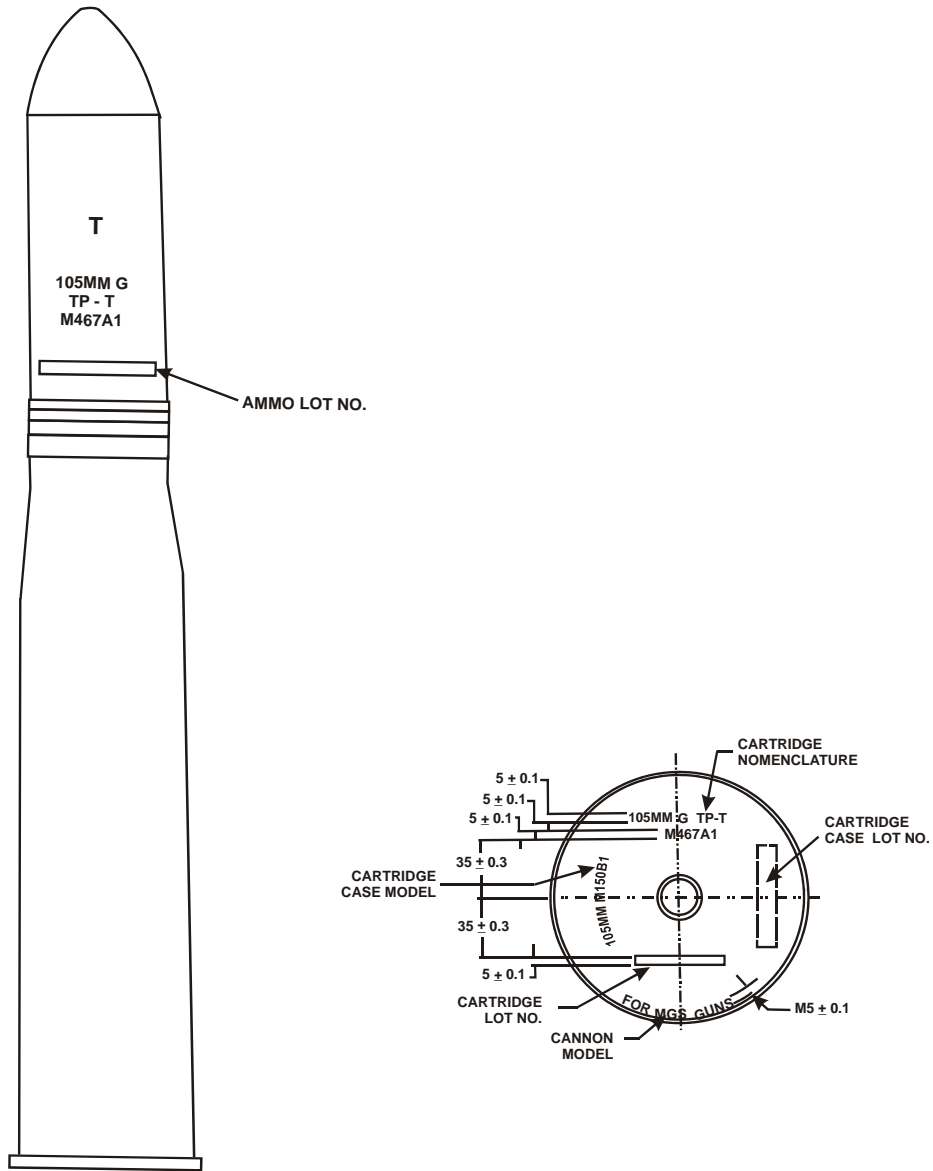

Figure E-55.1. Typical Marking for 105mm Gun Cartridge, M1040.



AR12523

Figure E-55.2. Typical Marking for 105mm Gun Cartridge, M393A3.



AR12541

Figure E-55.3. Typical Marking for 105mm Gun Cartridge M467A1.

THIS PAGE INTENTIONALLY LEFT BLANK

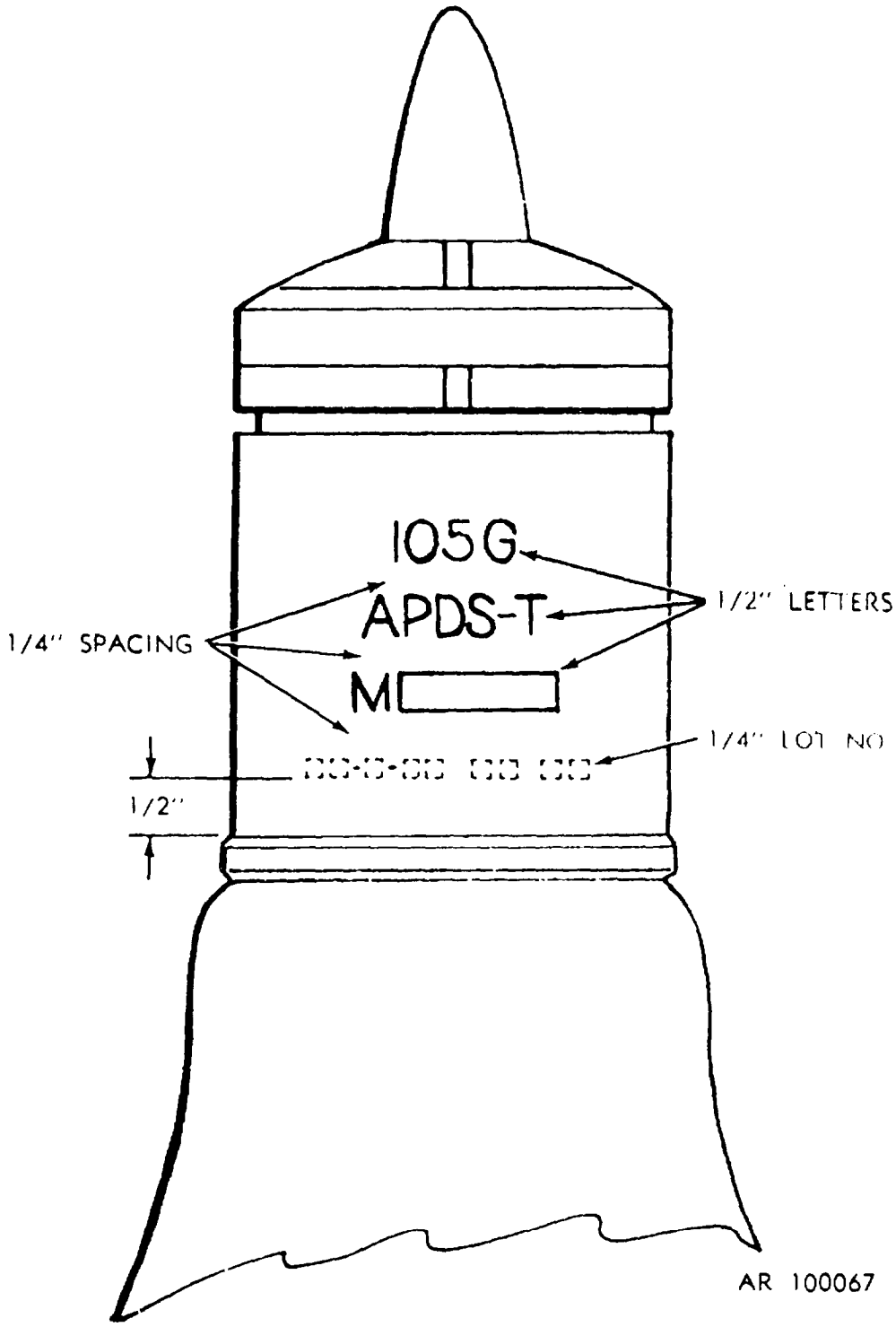

AR 100067

Figure E-56. Typical marking for 105mm gun cartridges M392 series and M724 series.

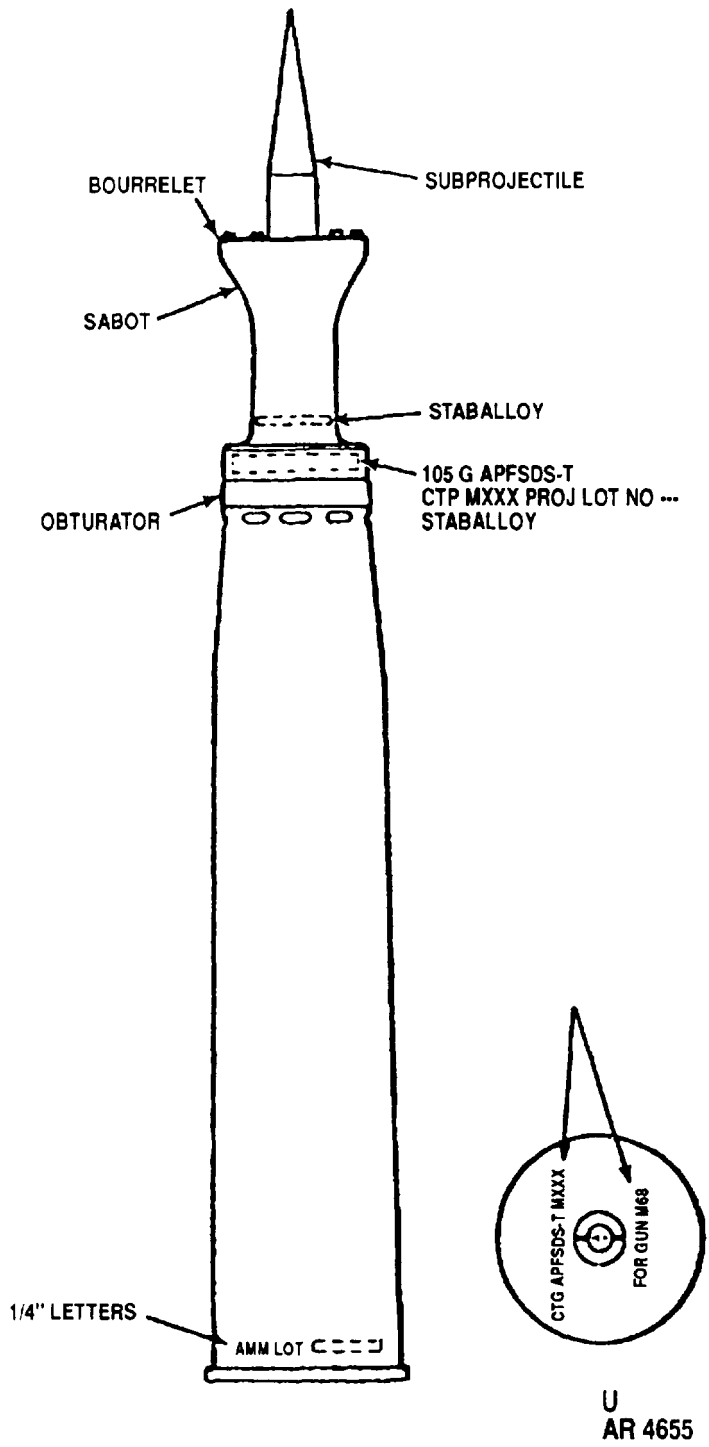

Figure E-57. Typical marking for 105mm gun cartridges M735, M774, M833 and M900.

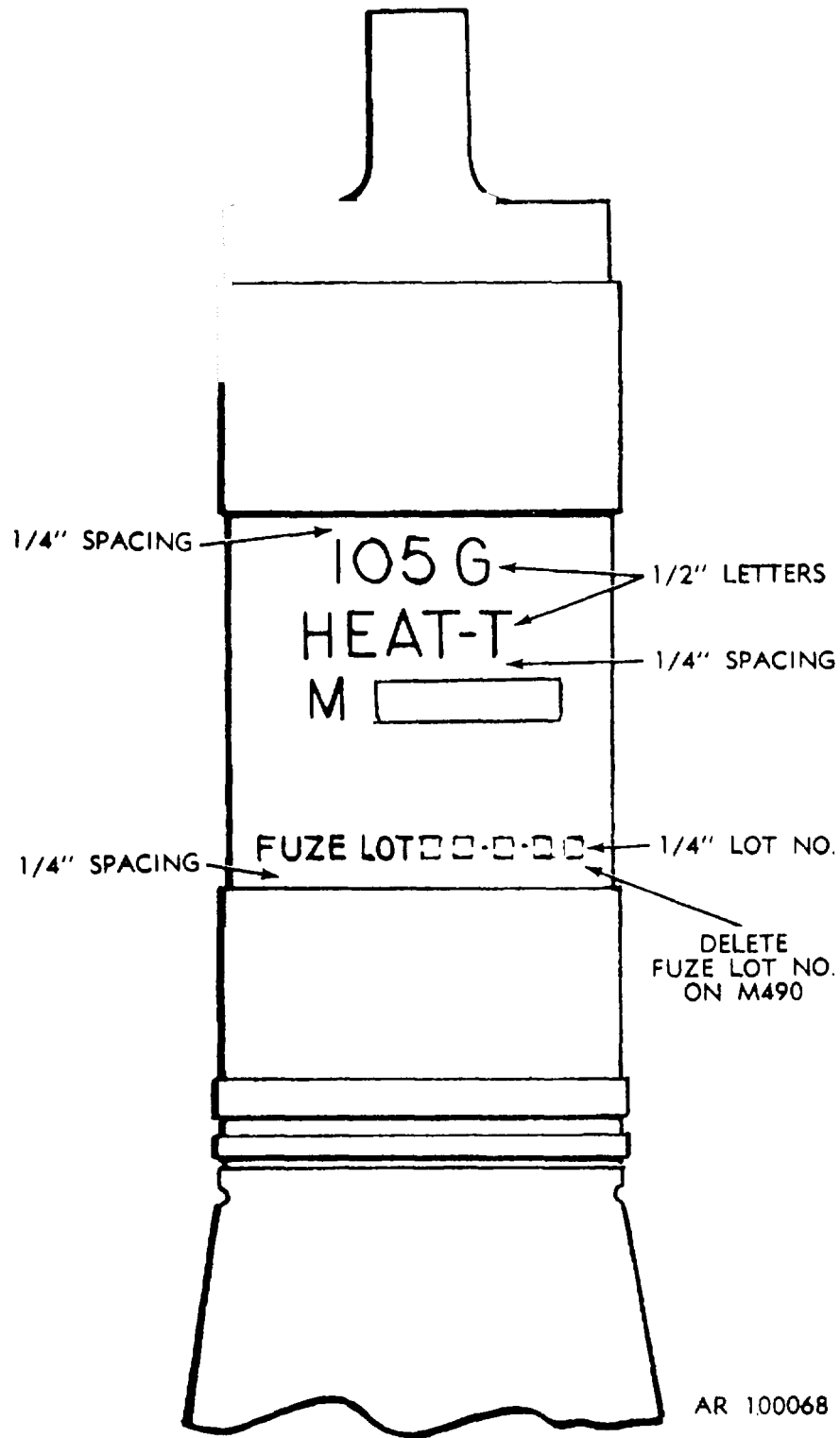

Figure E-58. Typical marking for 105mm gun cartridges M456 series and M490.

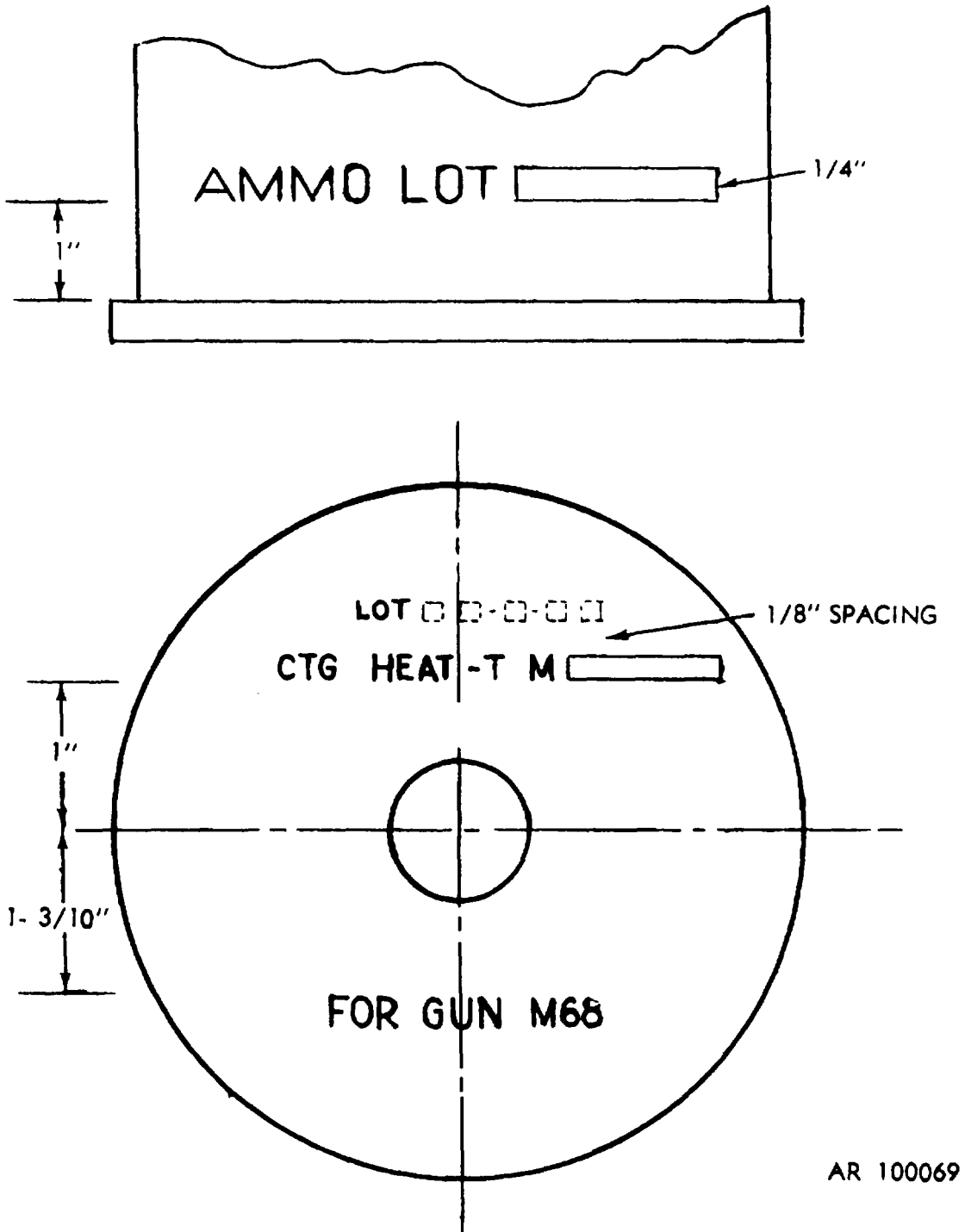

Figure E-59. Typical marking for cartridge case on 105mm gun cartridge M456 series.

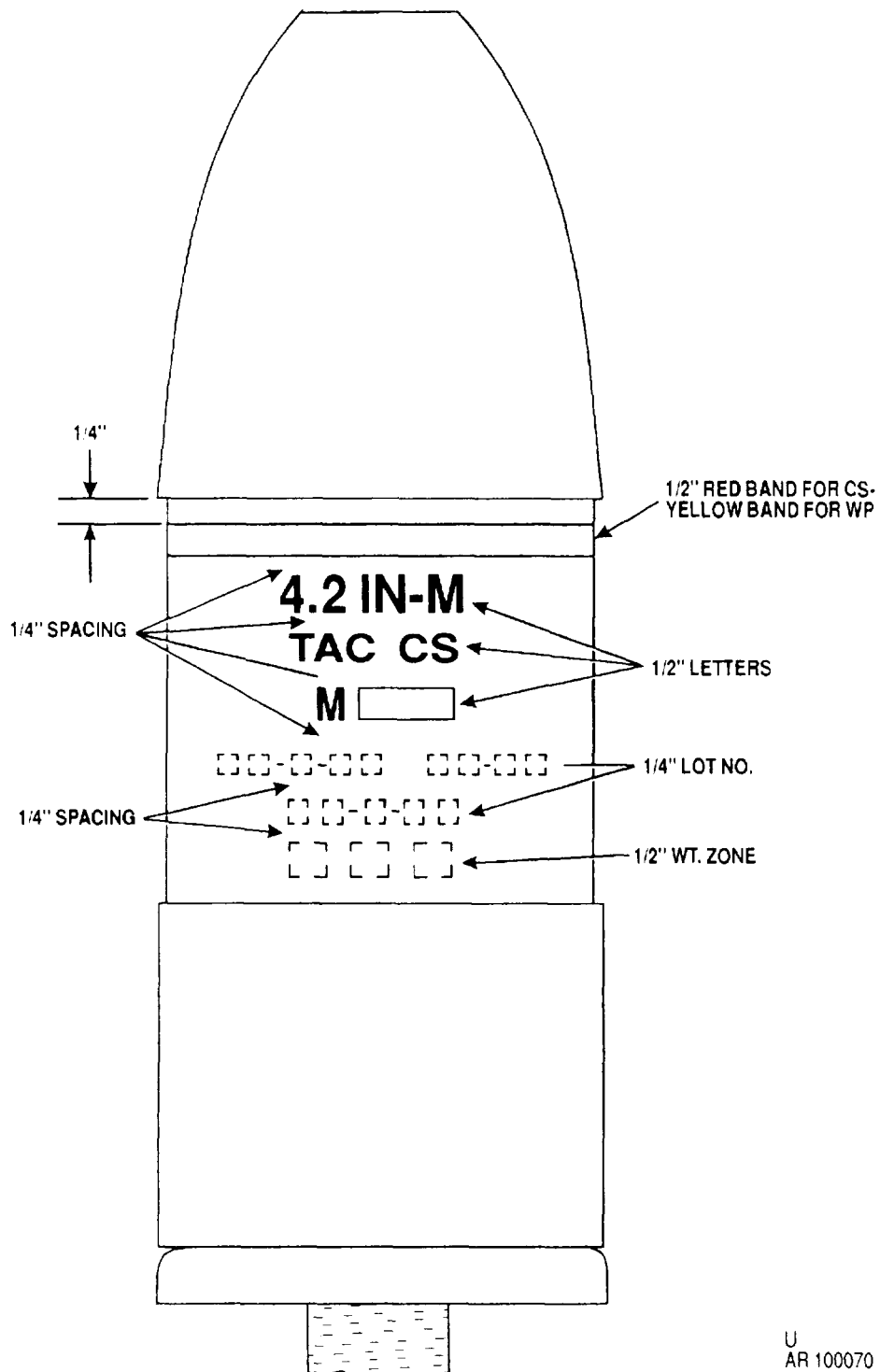

Figure E-60. Typical marking for 4.2-in. mortar cartridges M2, M630 and M328A1.

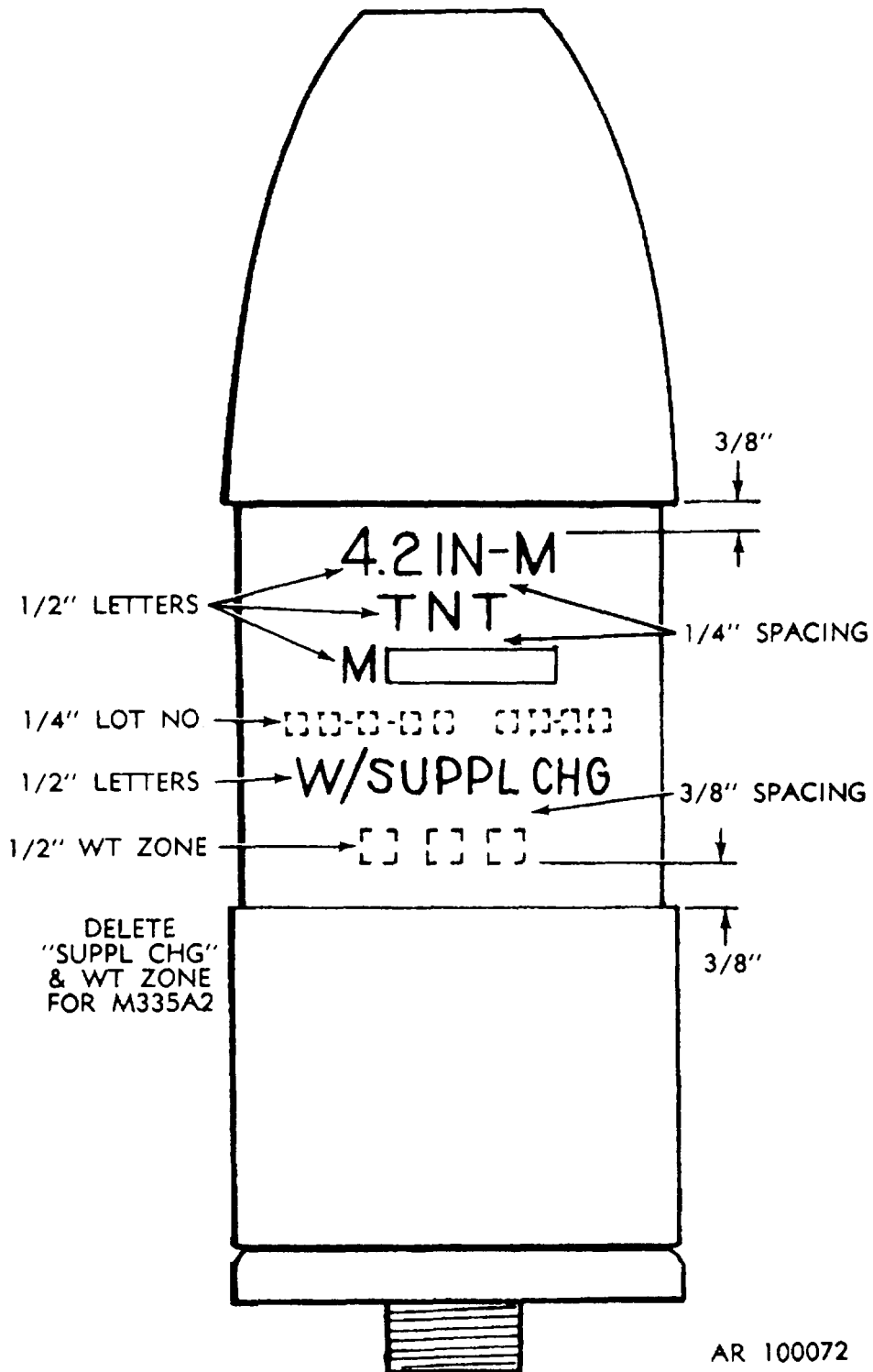

Figure E-61. Typical marking for 4.2-in. mortar cartridges M3 series, M329 series and M335A2.

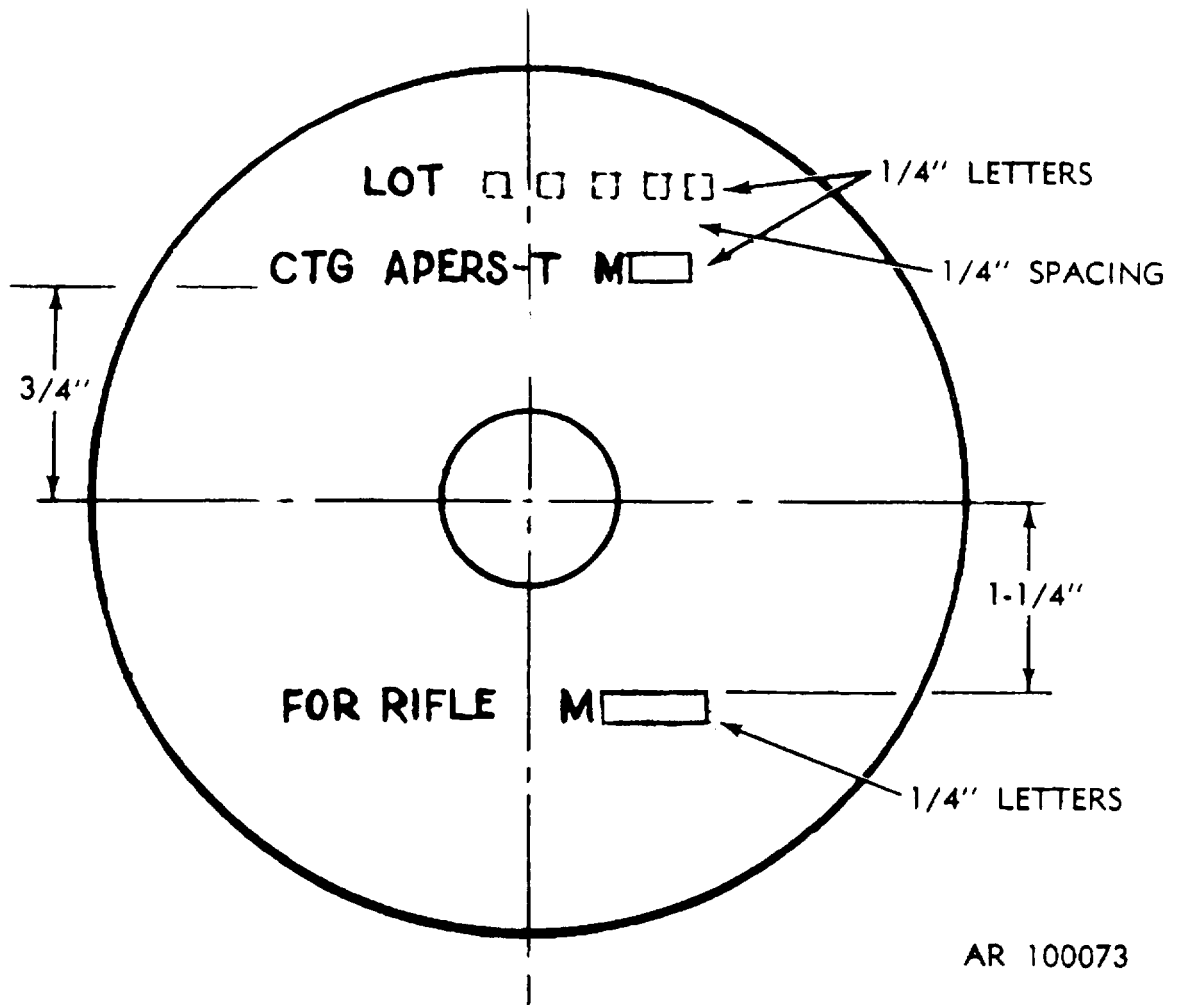

Figure E-62. Typical marking for cartridge case on 106mm rifle cartridge M581.

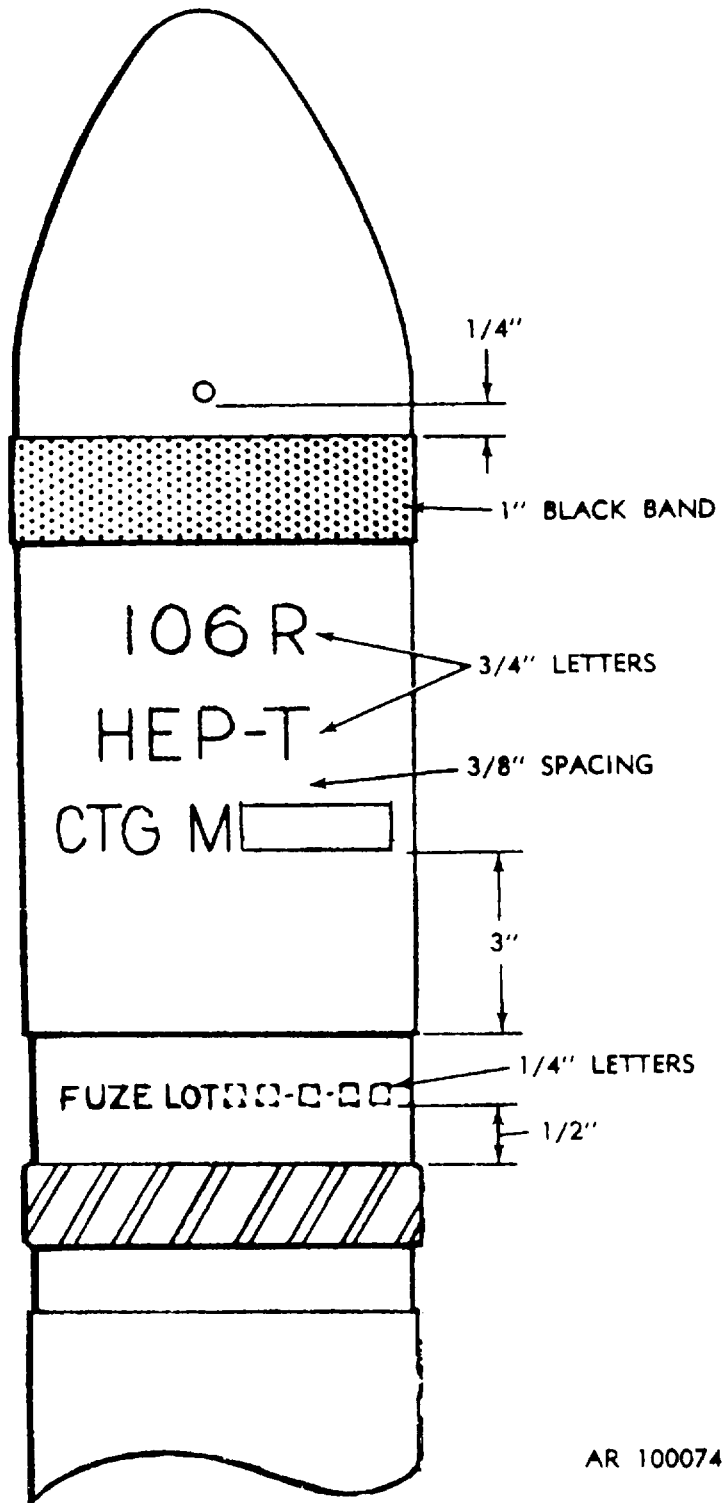

Figure E-63. Typical marking for 106mm rifle cartridge M346A1.

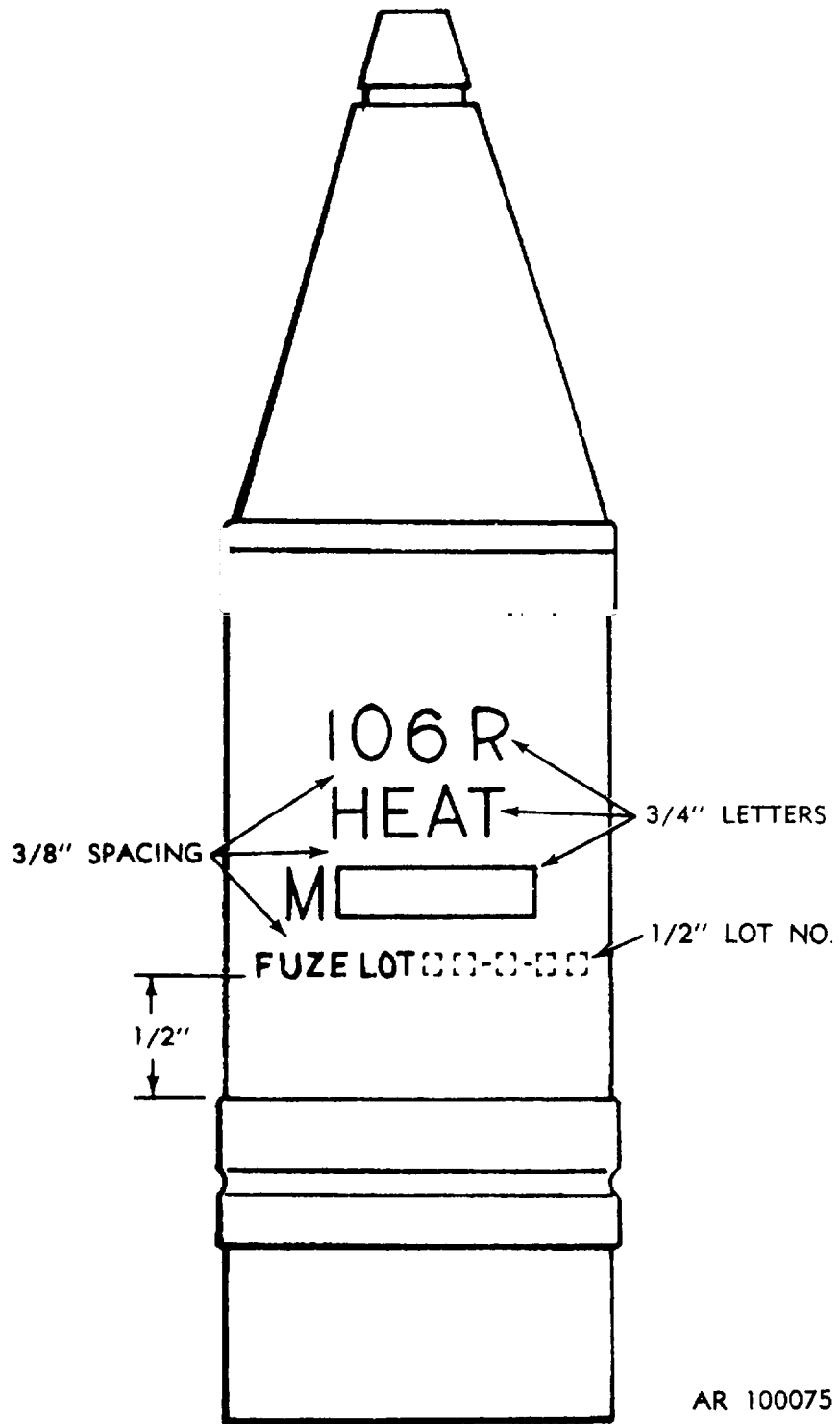

Figure E-64. Typical marking for 106mm rifle cartridge M344A1.

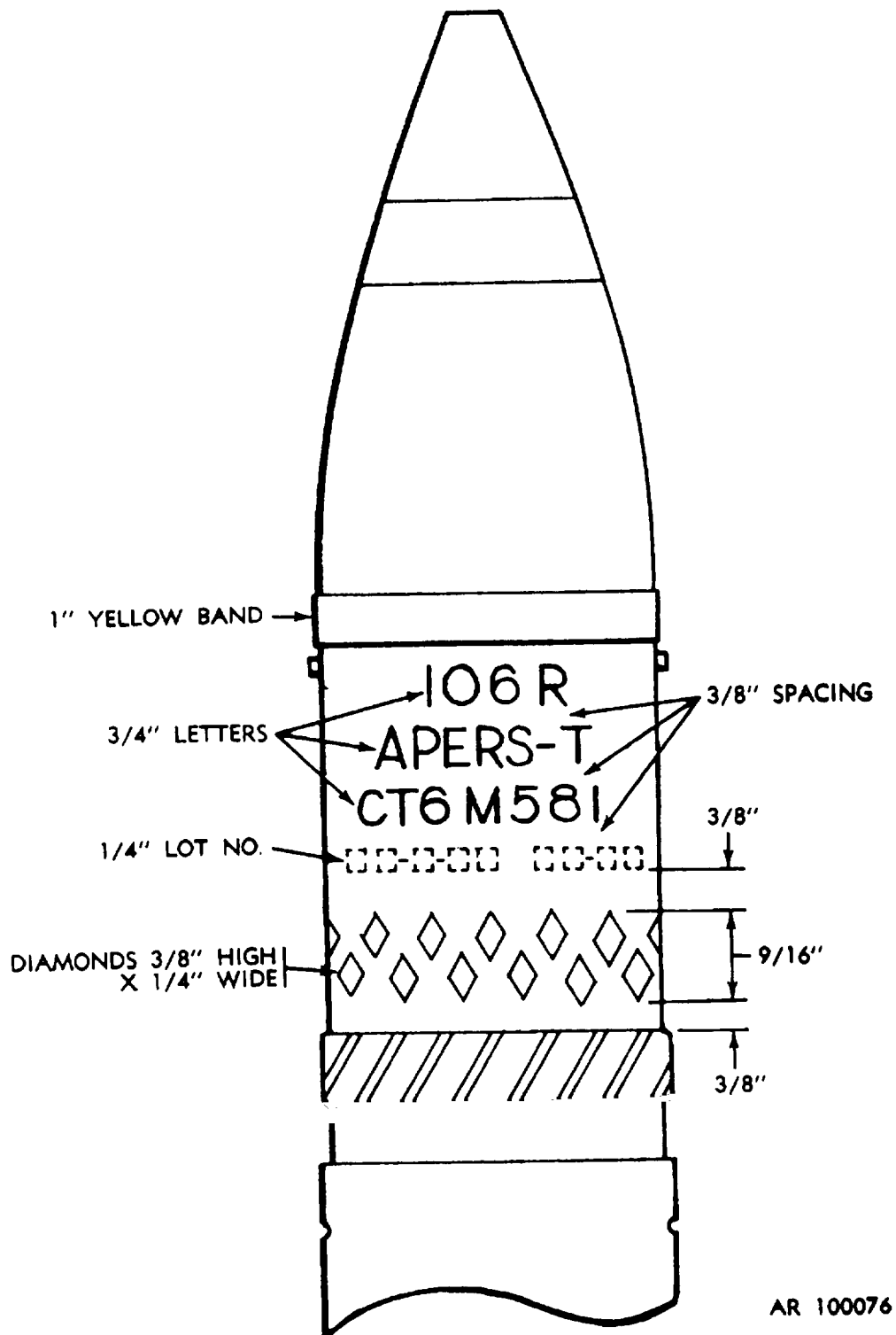
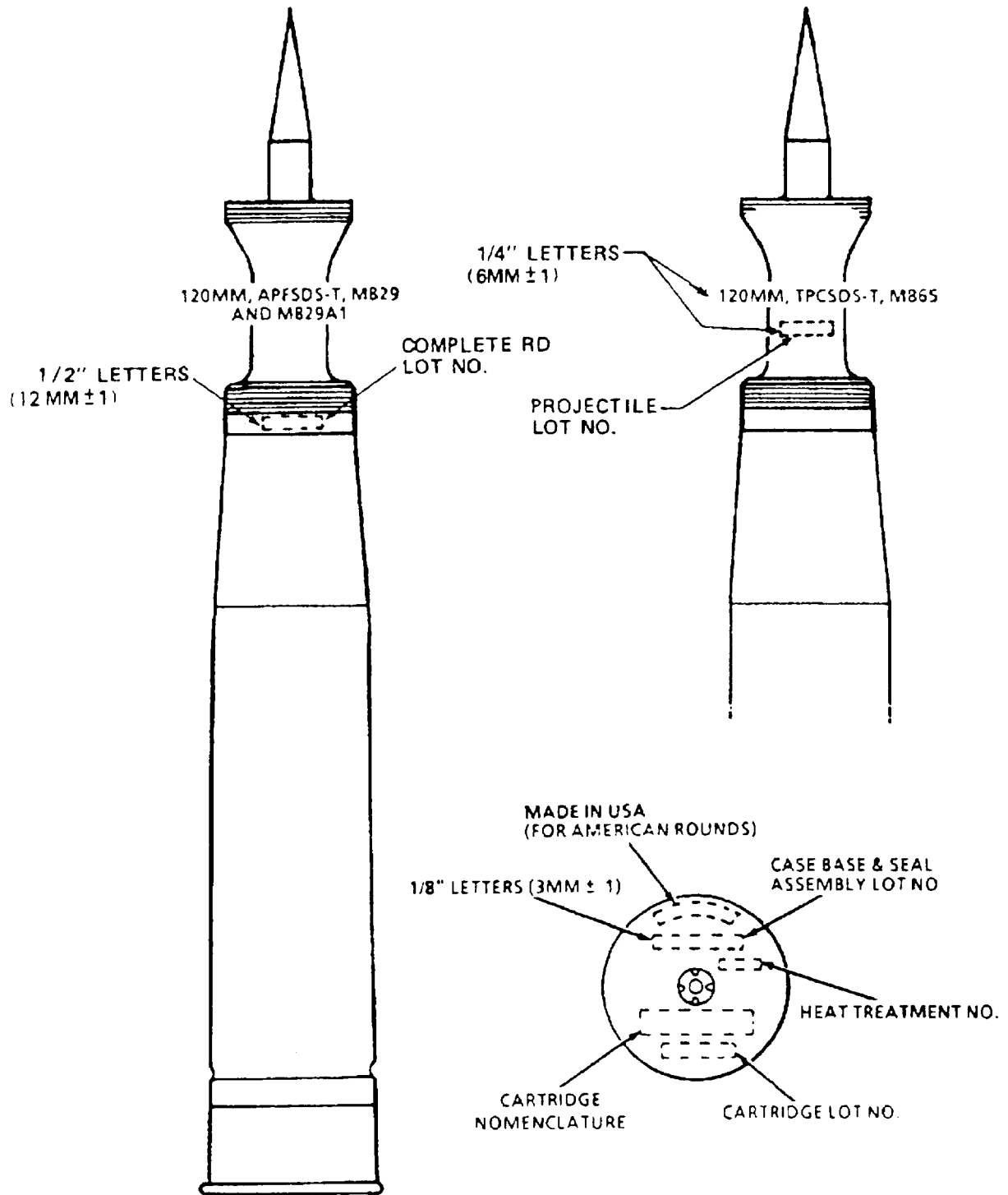

Figure E-65. Typical marking for 106mm rifle cartridge M581.



U
AR 5796

Figure E-66. Typical marking for 120mm gun cartridges, M829, M829A1 and M865.

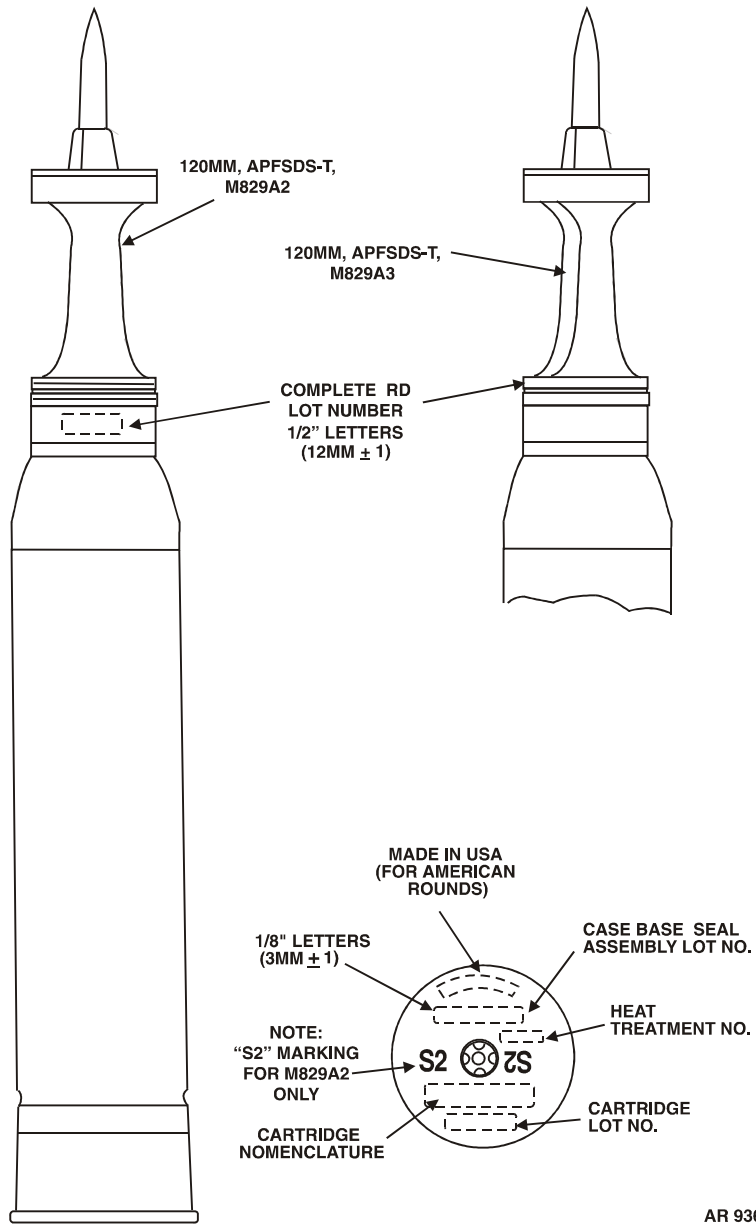

Figure E-67. Typical Marking for 120mm Gun Cartridges M829A2 and M829A3.

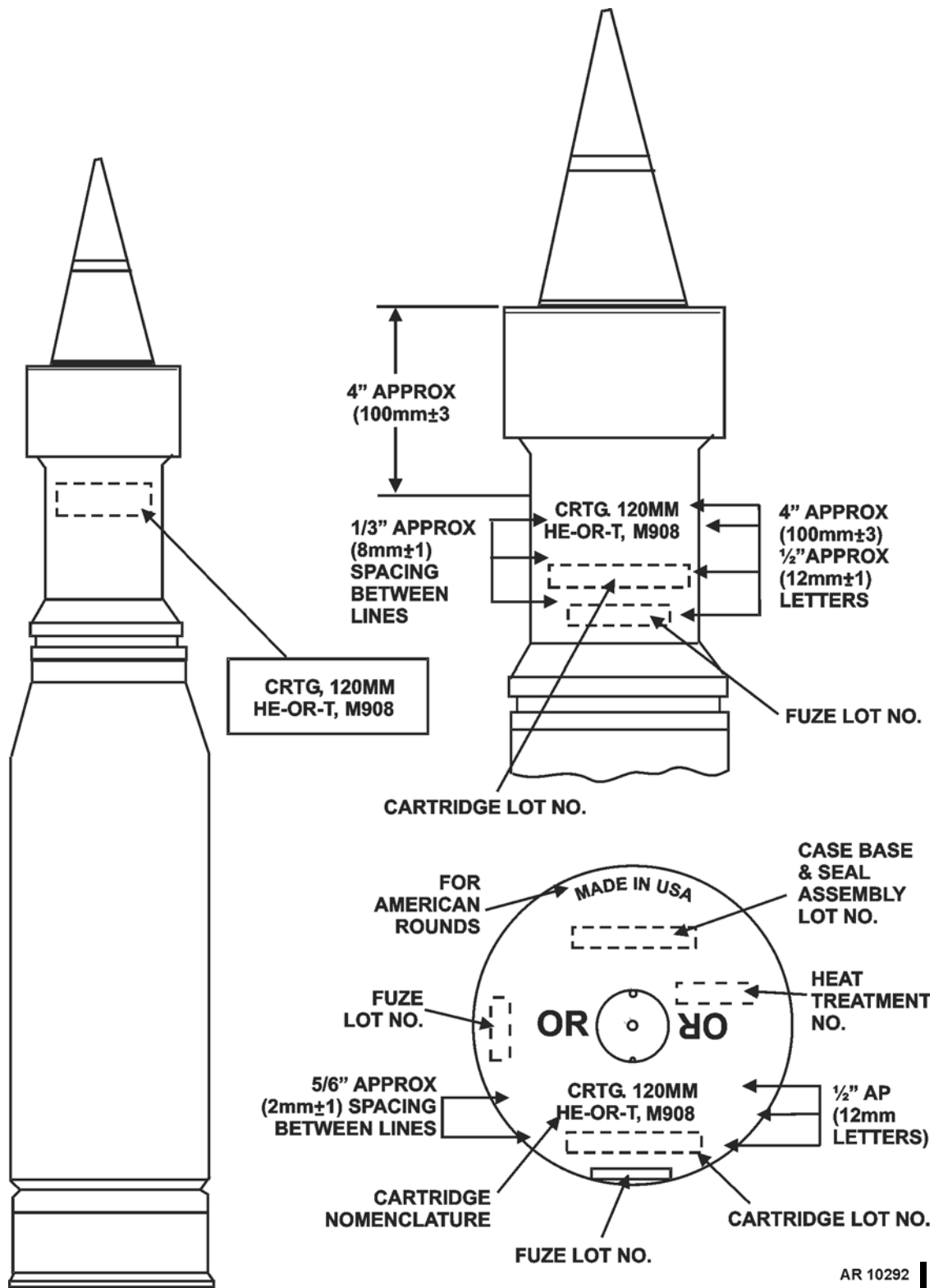

Figure E-67.1. Typical Marking for 120mm Gun Cartridge, HE-OR-T, M908.

THIS PAGE INTENTIONALLY LEFT BLANK

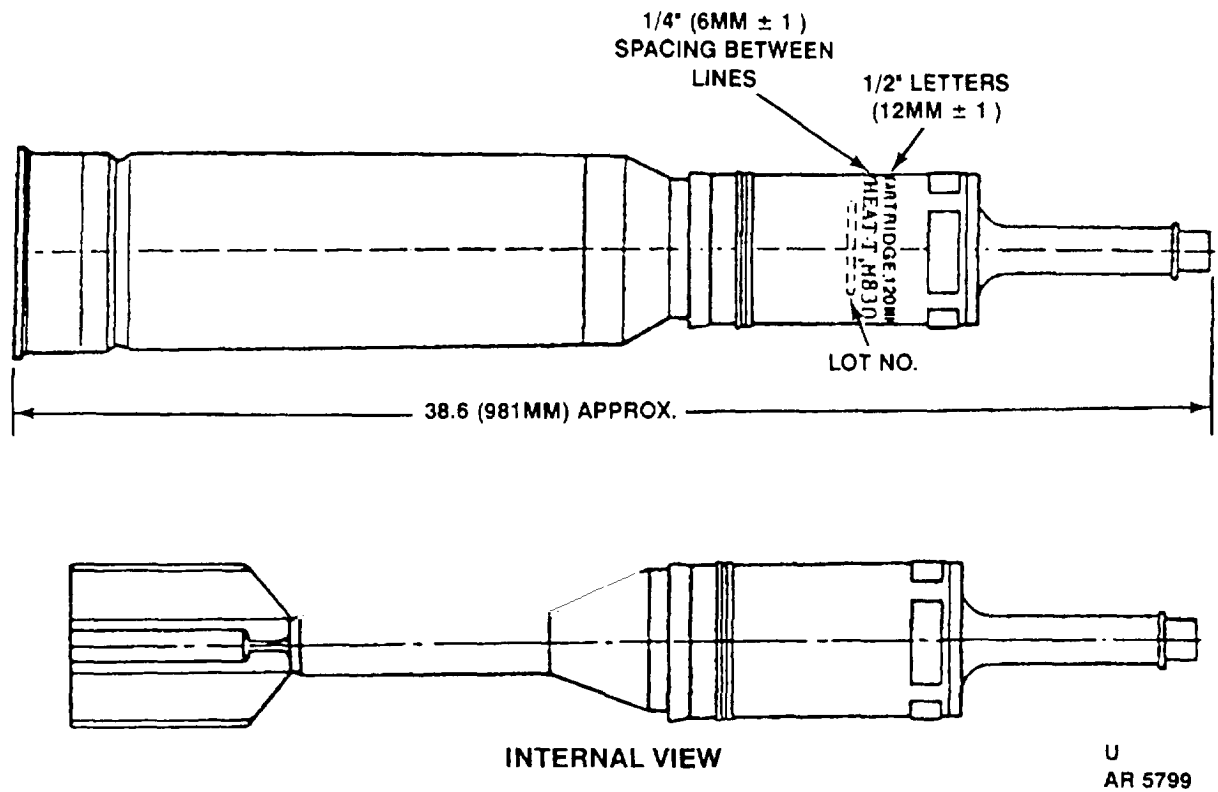

Figure E-68. Typical marking for 120mm gun cartridge, M830.

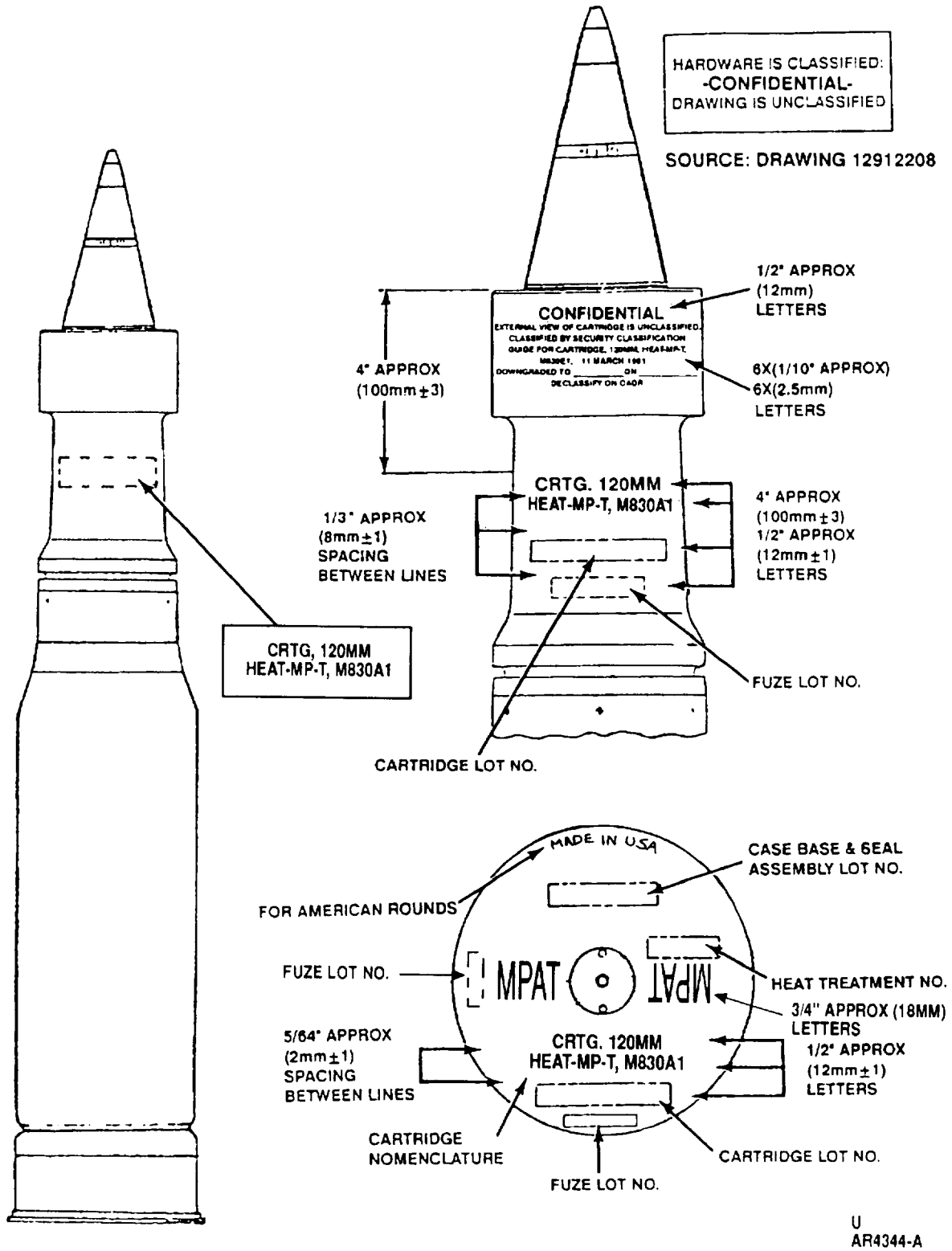

Figure E-69. Typical marking for 120mm gun cartridge HEAT-MP-T, M830A1.

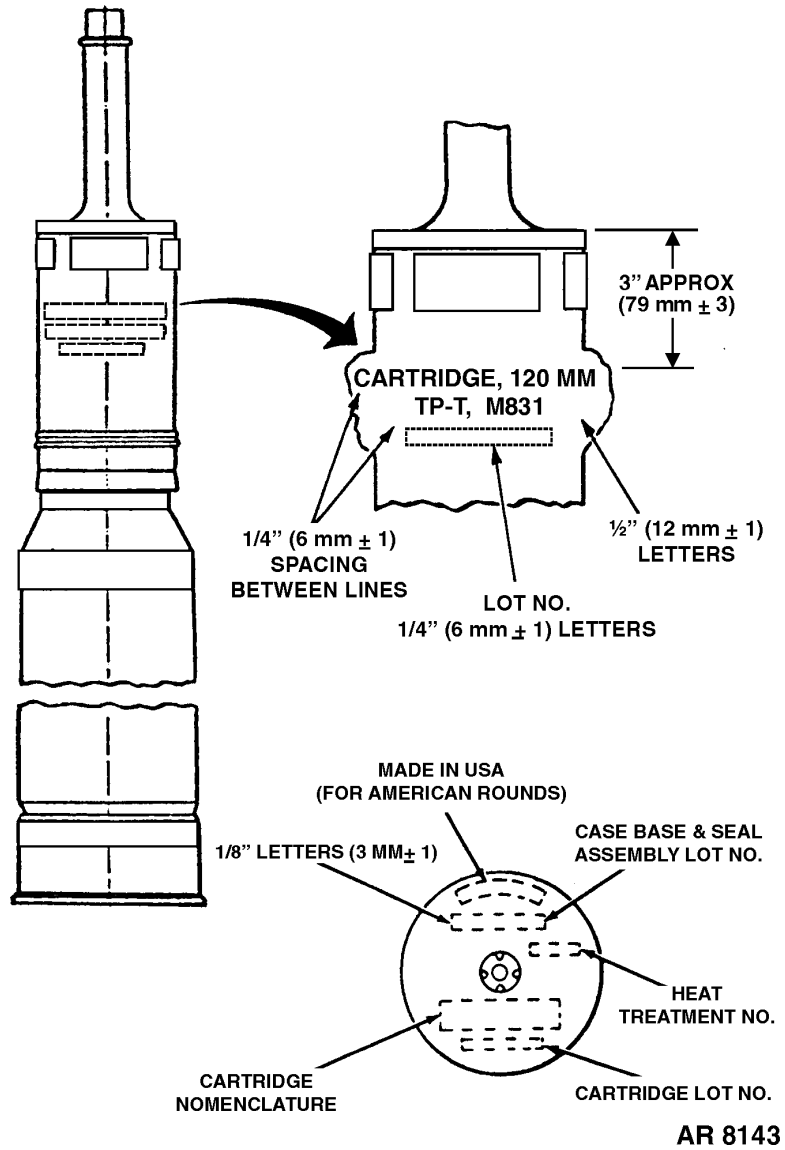
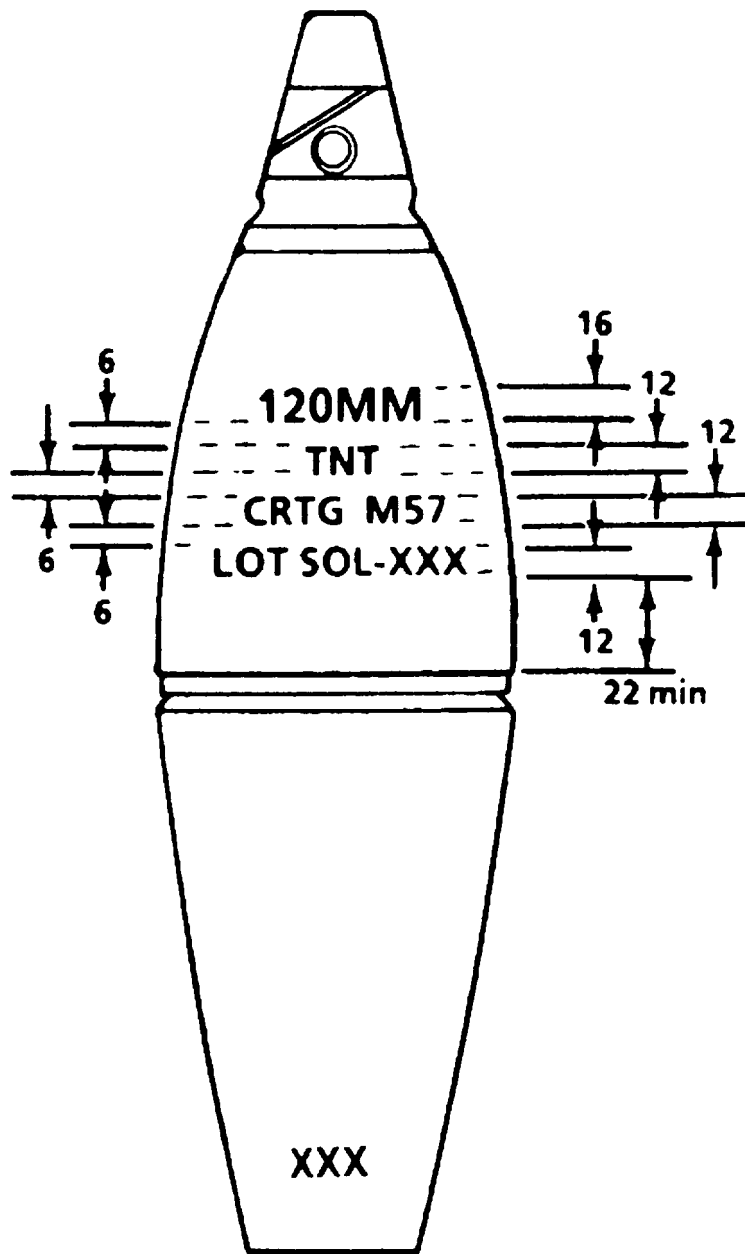

Figure E-70. Typical Marking for 120mm Gun Cartridges M831 and M831A1.



U
AR 4294

Figure E-71. Typical marking for 120mm mortar cartridges M57 series.

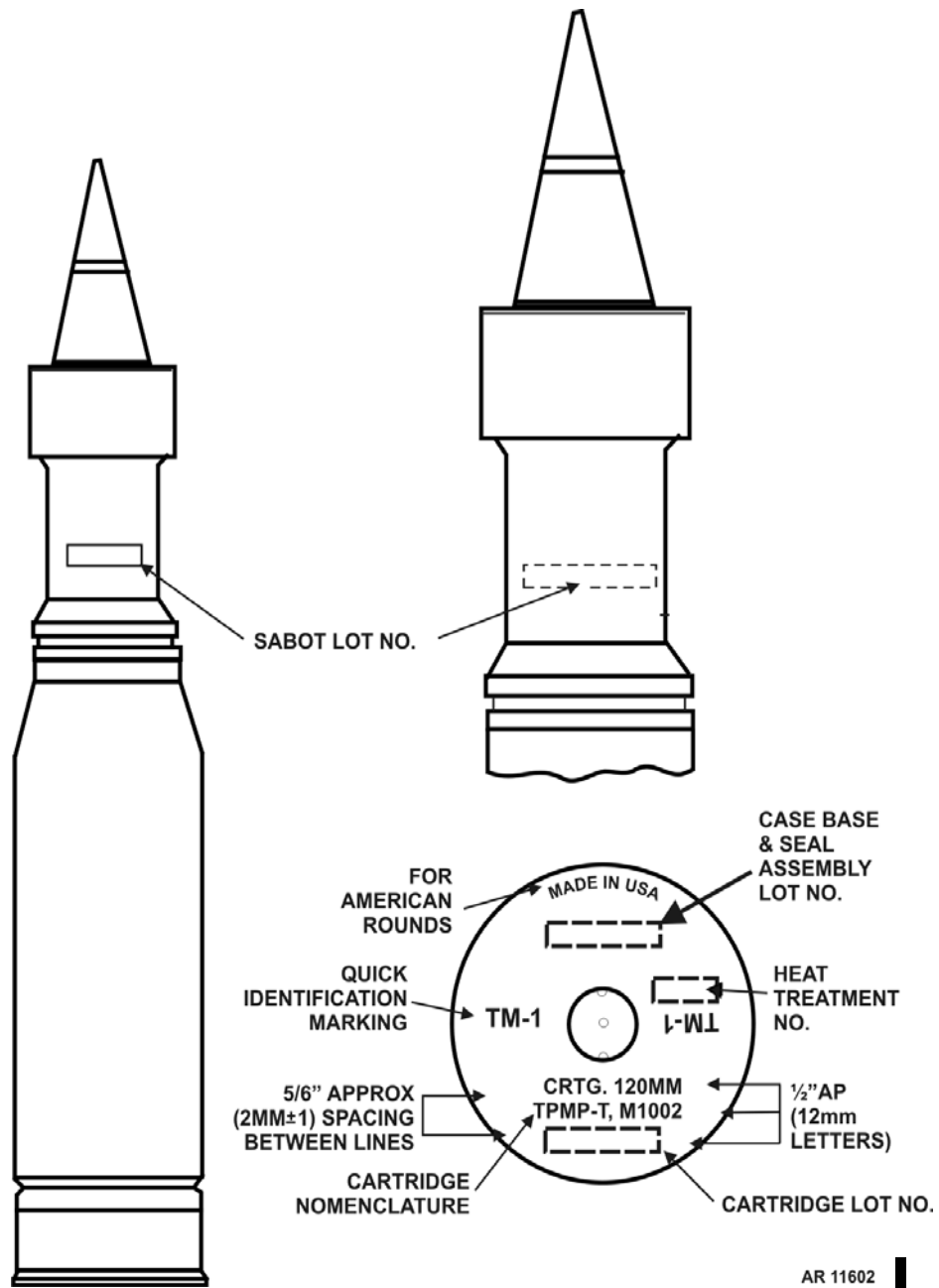

Figure E-71.1. Typical Marking for 120mm Gun Cartridge, TPMP-T, M1002.

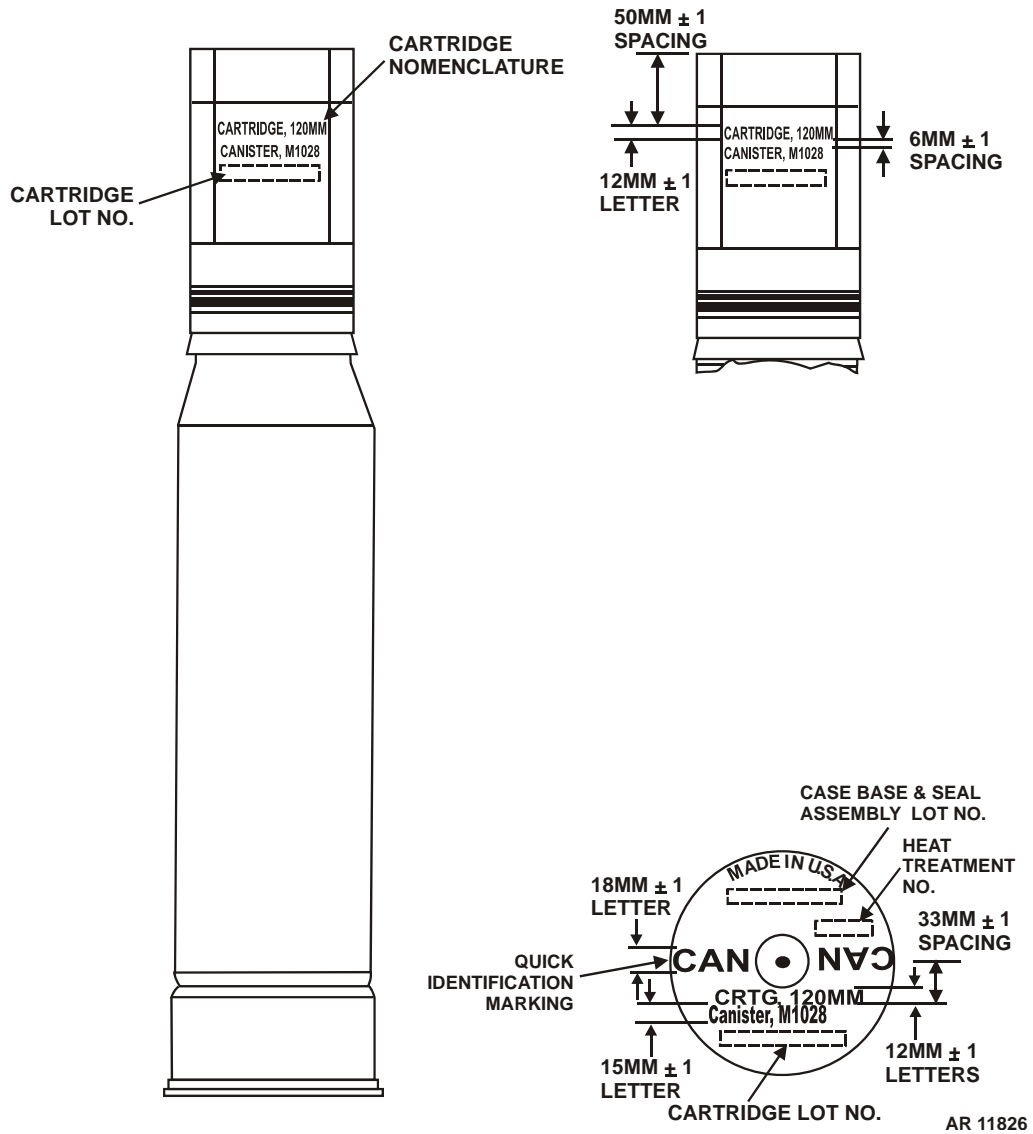
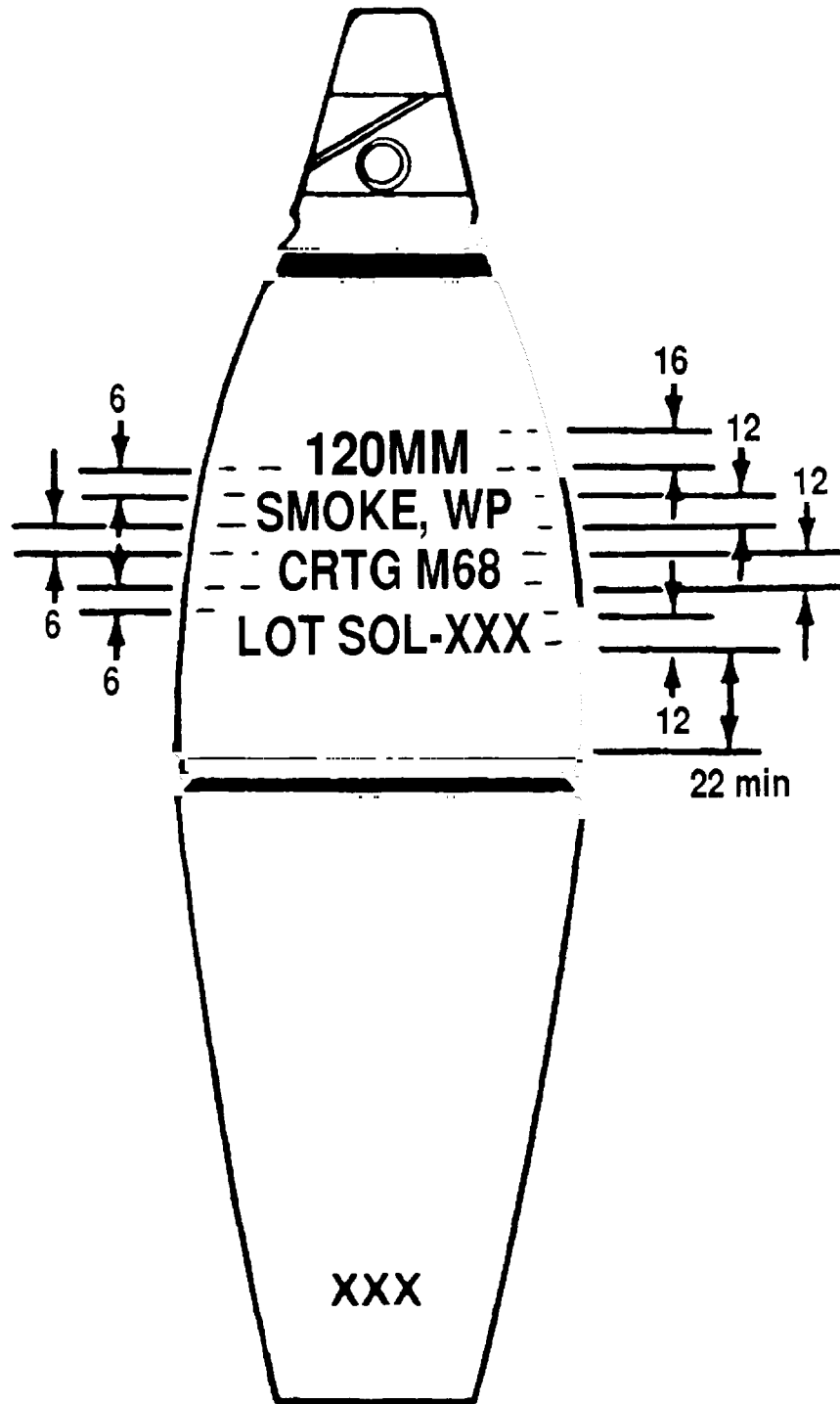
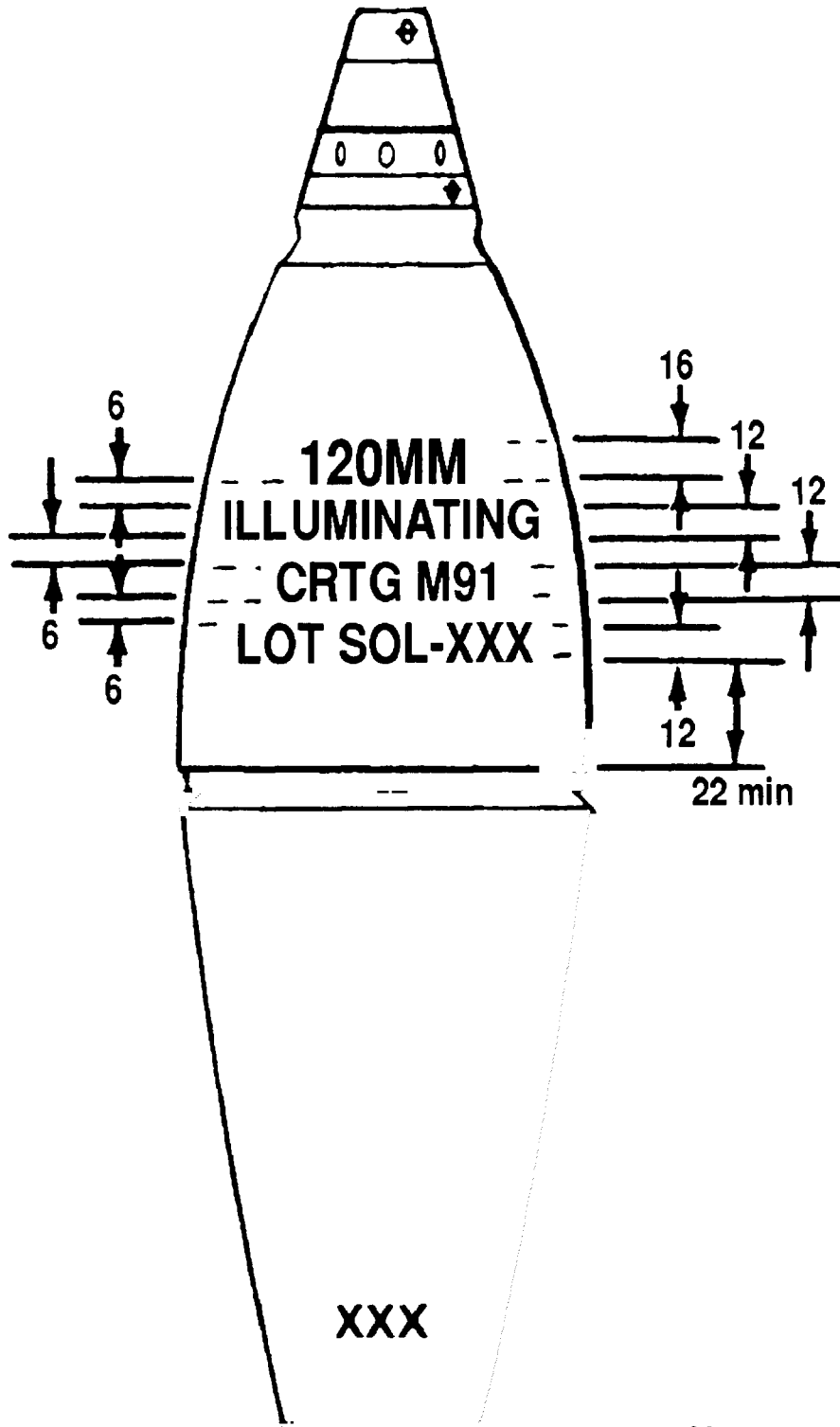

Figure E-71.2. Typical Marking for 120mm Gun Cartridge, Canister, M1028.



U
AR 4295

Figure E-72. Typical marking for 120mm mortar cartridges M68 series.



U
AR 4296

Figure E-73. Typical marking for 120mm mortar cartridges M91 series.

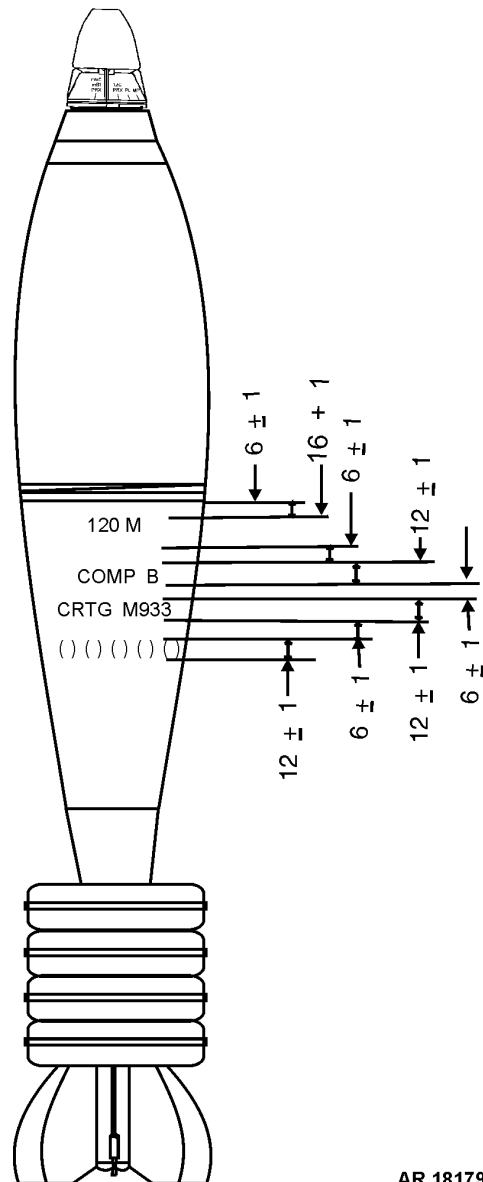

NOTE: Units are in millimeters.

AR 18179

Figure E-74. Typical marking for 120mm mortar cartridge M933 and M933A1.

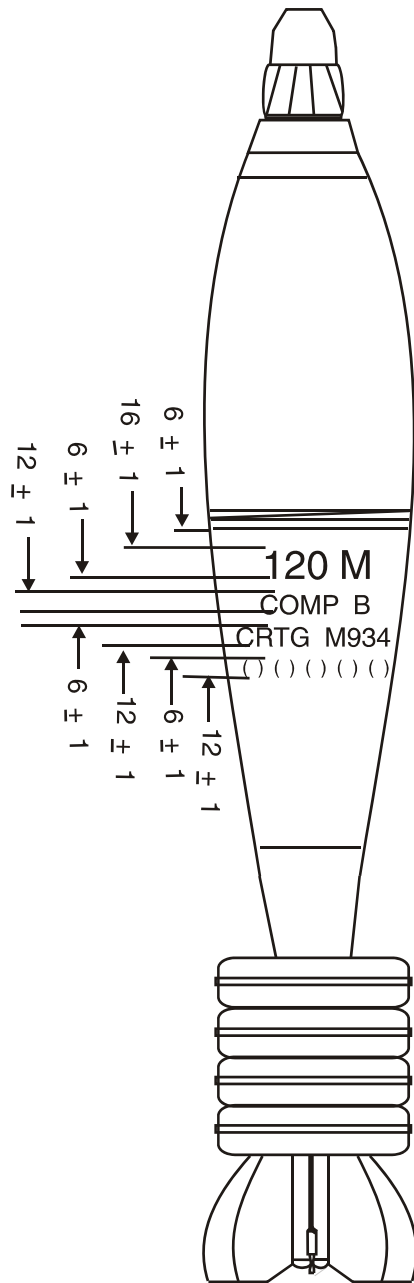

AR 10795

Figure E-75. Typical marking for 120mm Mortar Cartridges M934 and M934A1.

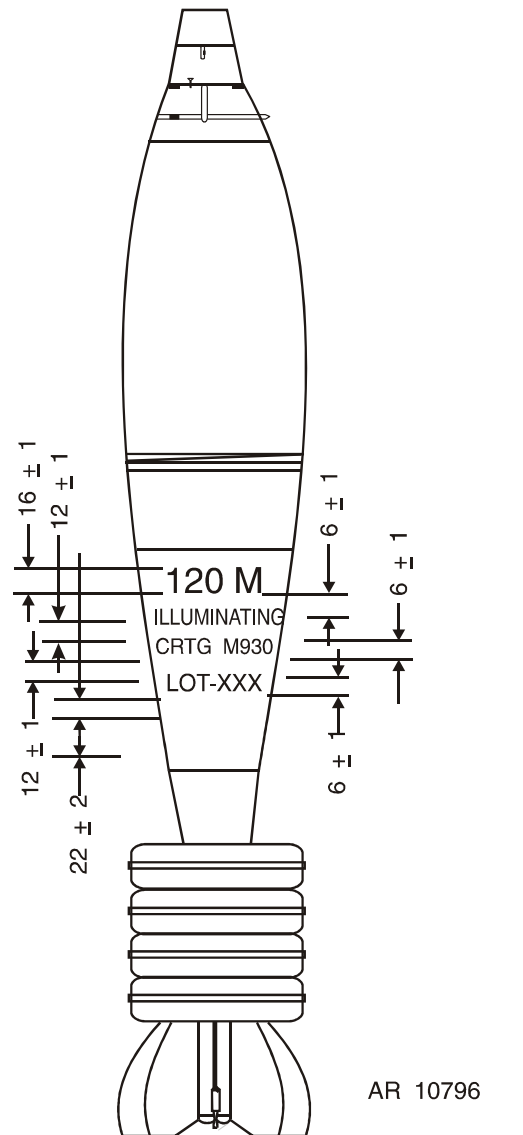
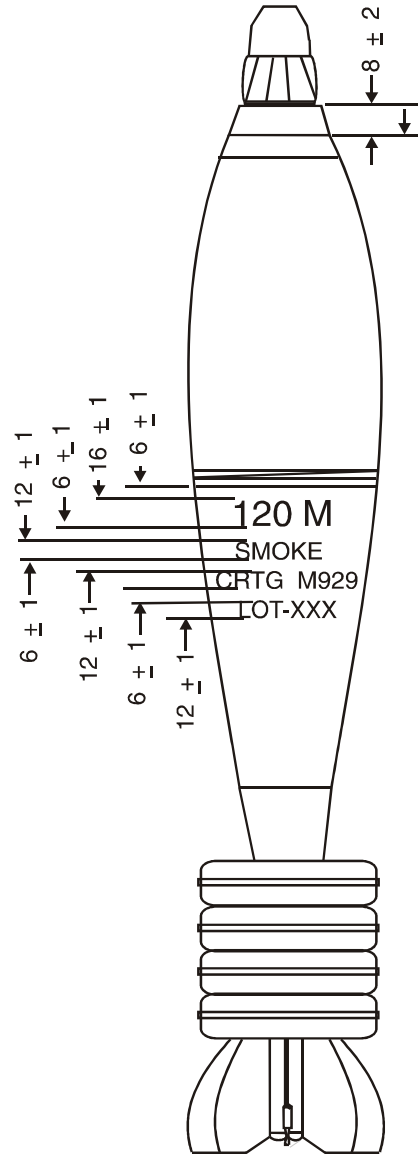

Figure E-76. Typical marking for 120mm Mortar Cartridges M930 and M983.



AR 10797

Figure E-77. Typical marking for 120mm Mortar Cartridge, XM929 and M929.

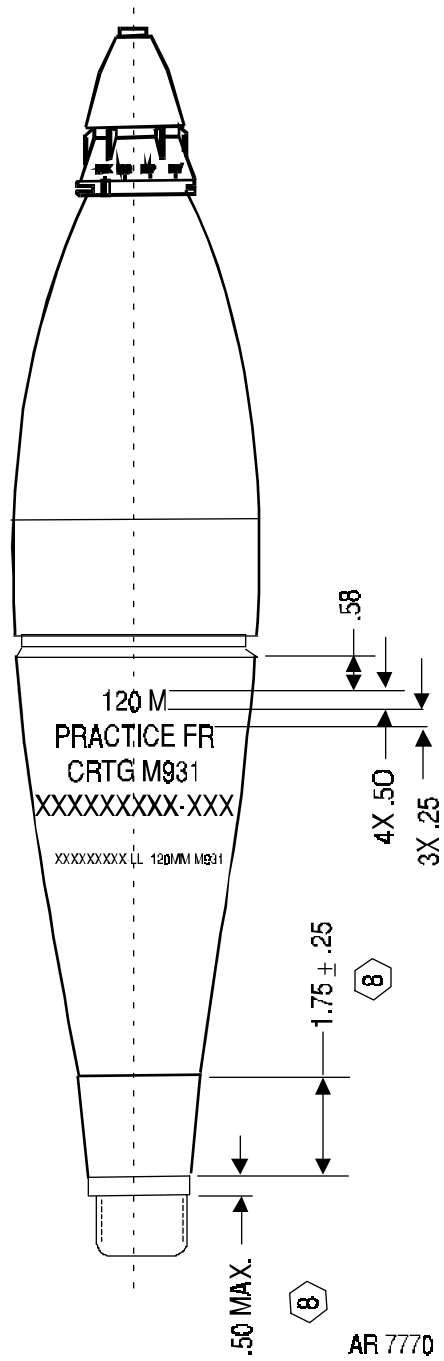
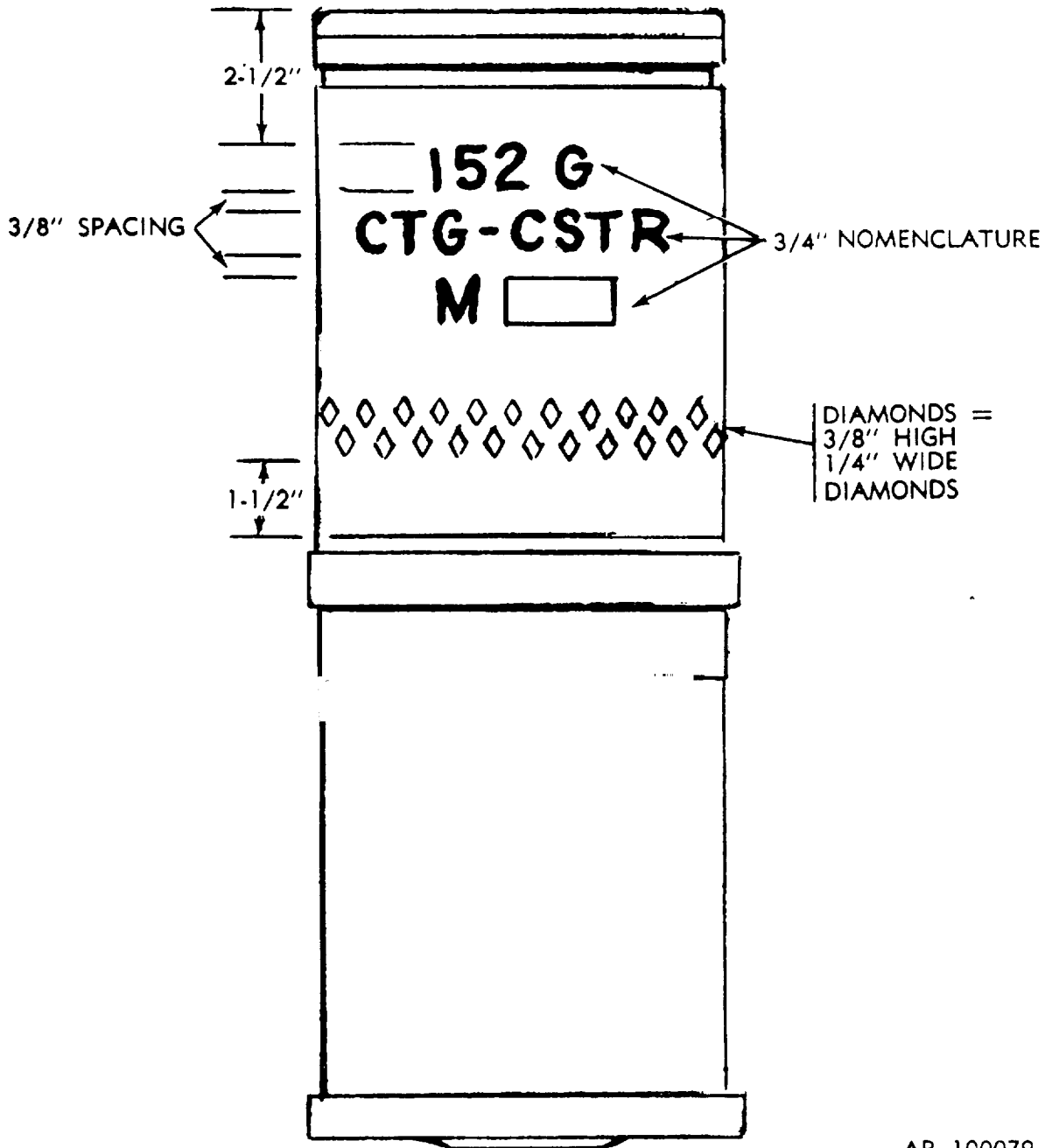

Figure E-78. Typical marking for 120mm mortar cartridge M931.

THIS PAGE INTENTIONALLY LEFT BLANK



AR 100079

Figure E-80. Typical marking for 152mm gun cartridge M625.

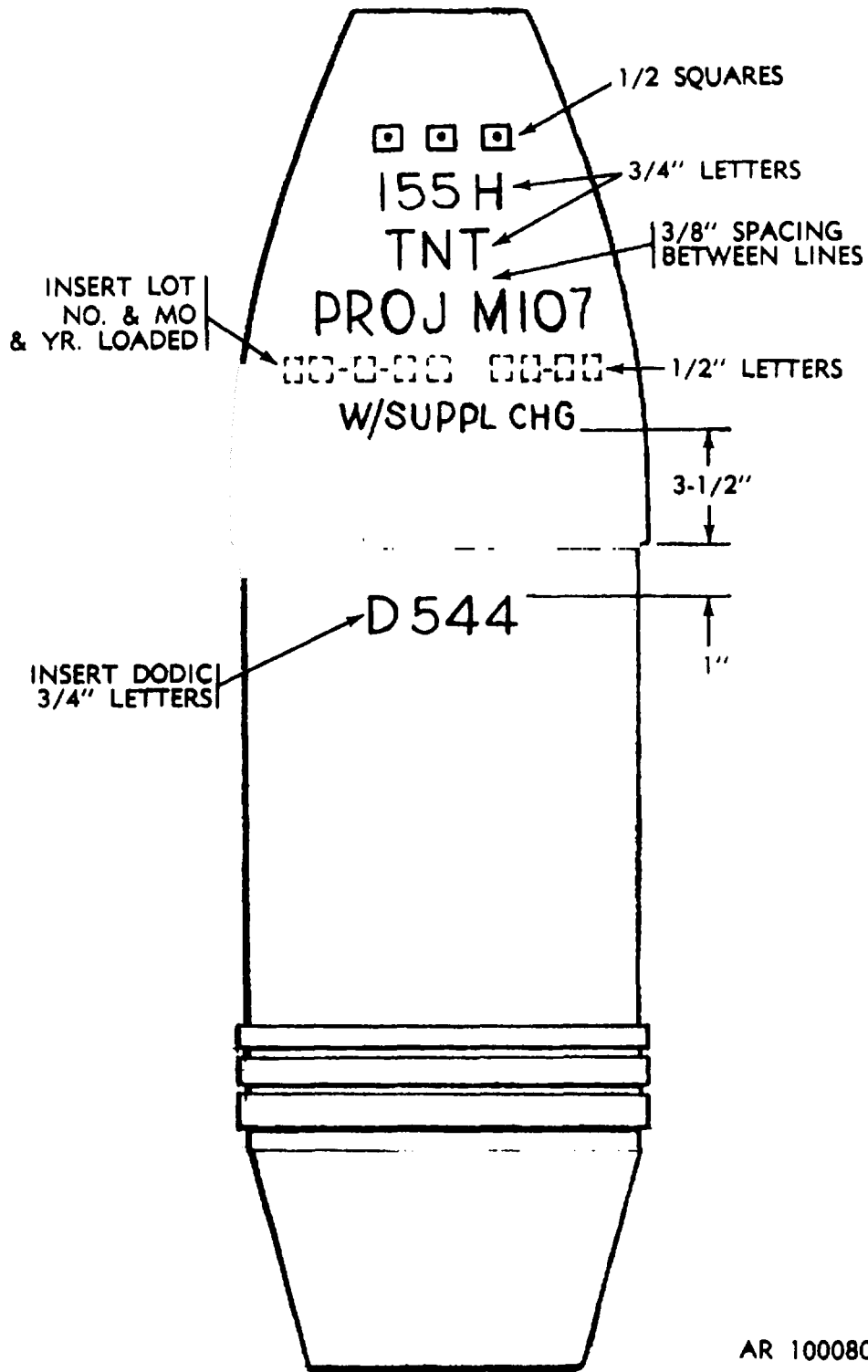

AR 100080

Figure E-81. Typical marking for 155mm howitzer projectiles M107, M110 series and M116 series.

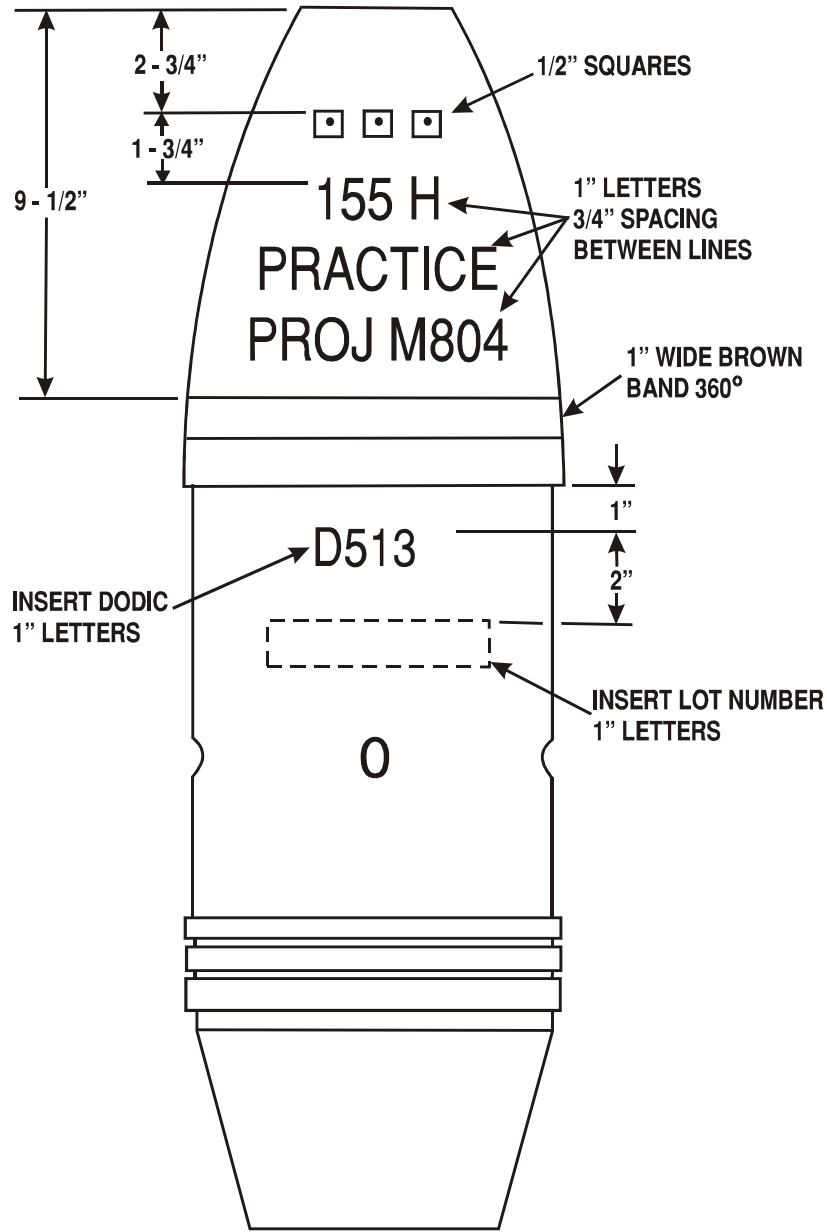

AR8936

Figure E-82. Typical Marking for 155mm Howitzer Projectile M804.

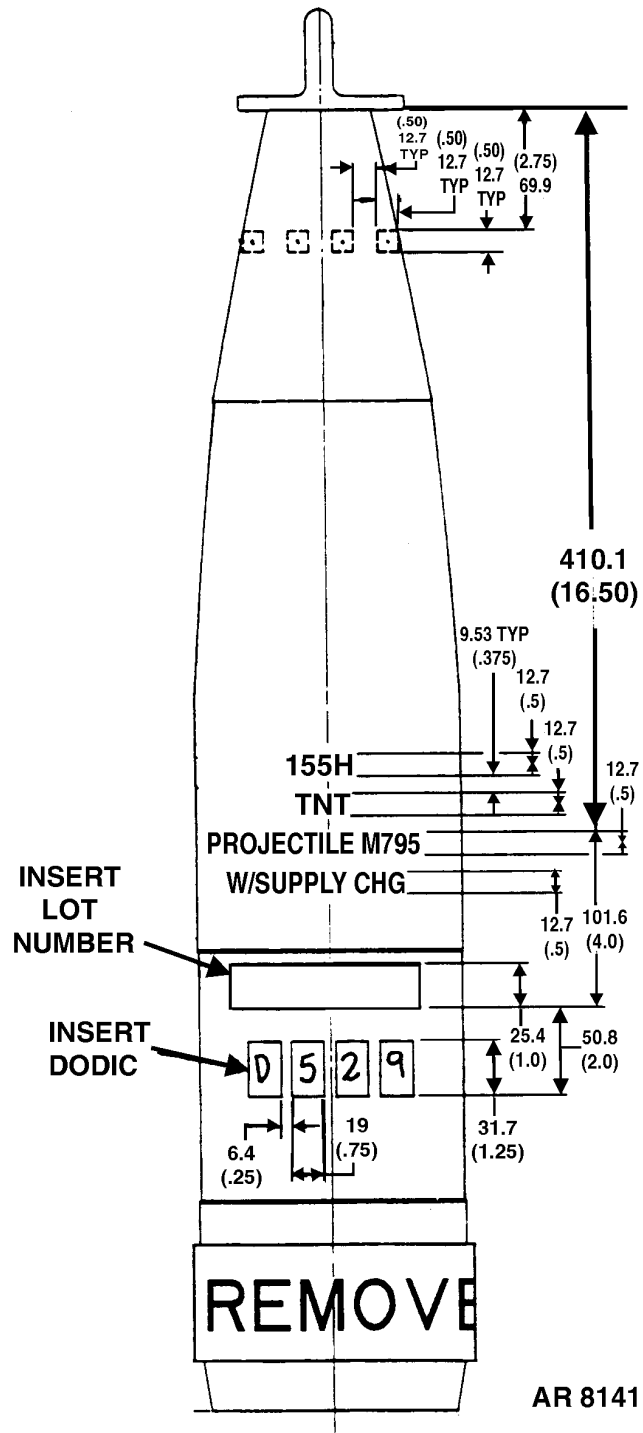
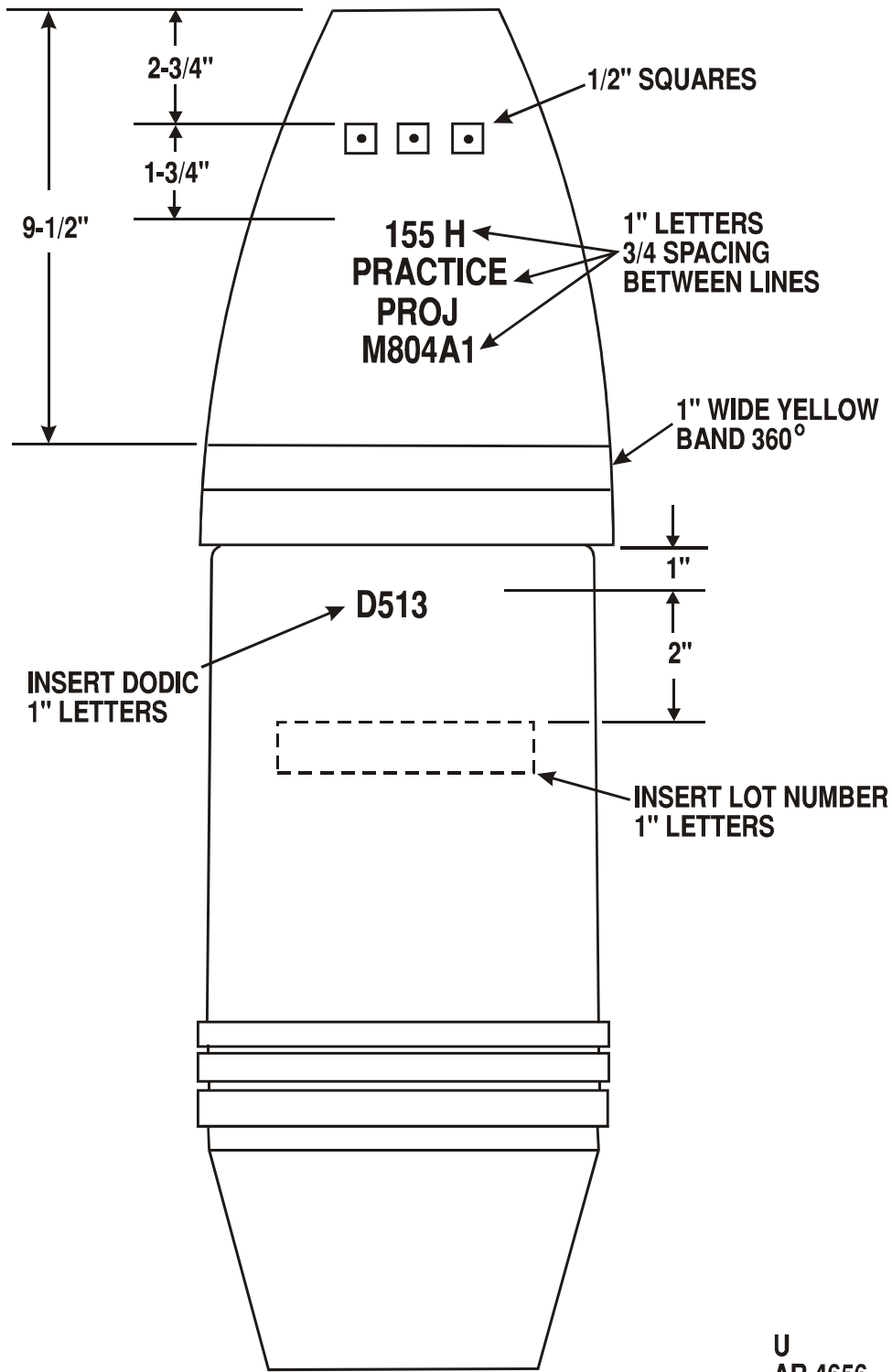

Figure E-82.1. Typical Marking for 155mm Howitzer Projectile M795.



U
AR 4656

Figure E-83. Typical Marking for 155mm Howitzer Projectile M804A1.

THIS PAGE INTENTIONALLY LEFT BLANK

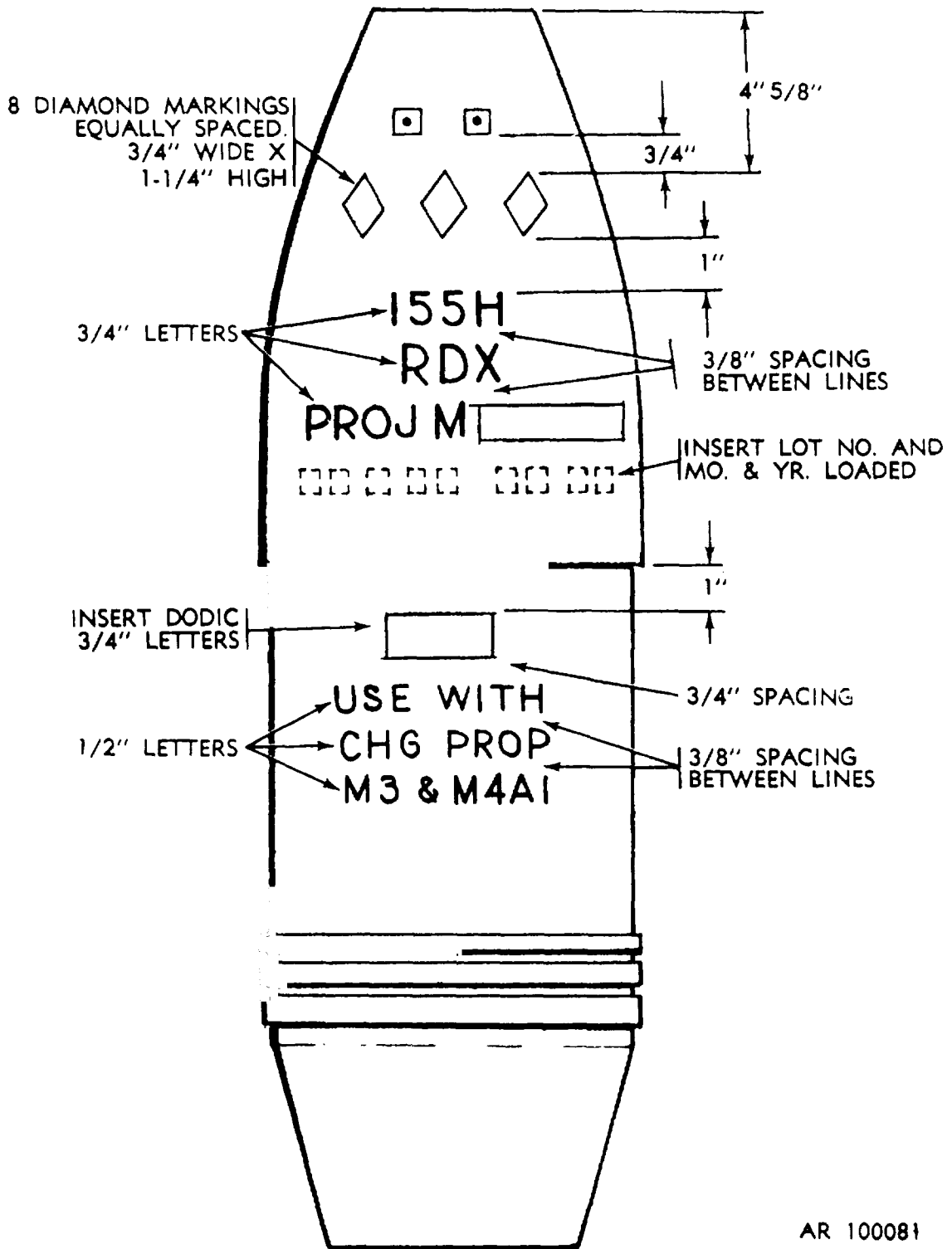
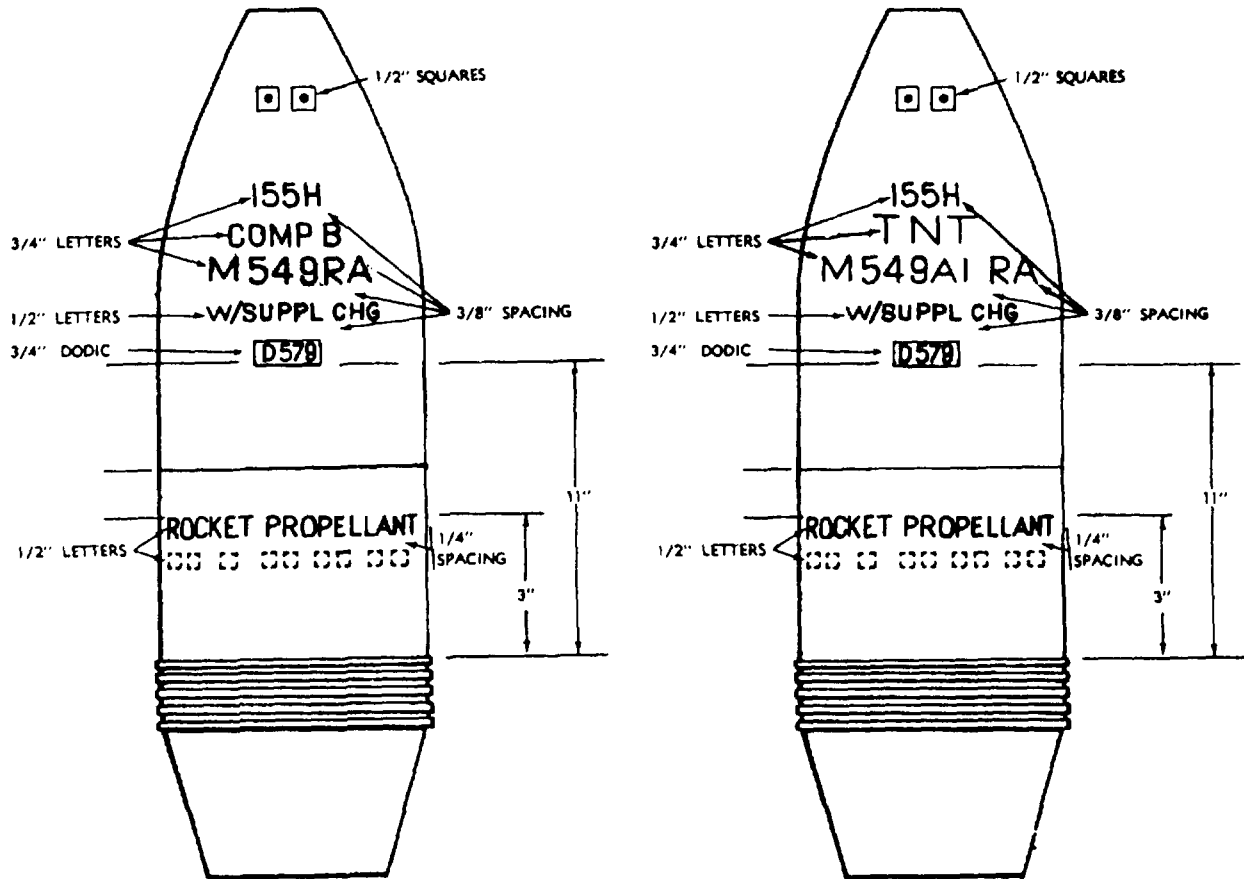

Figure E-84. Typical marking for 155mm howitzer projectile M449A1.



AR 101877

Figure E-85. Typical marking for 155mm howitzer projectile M549.

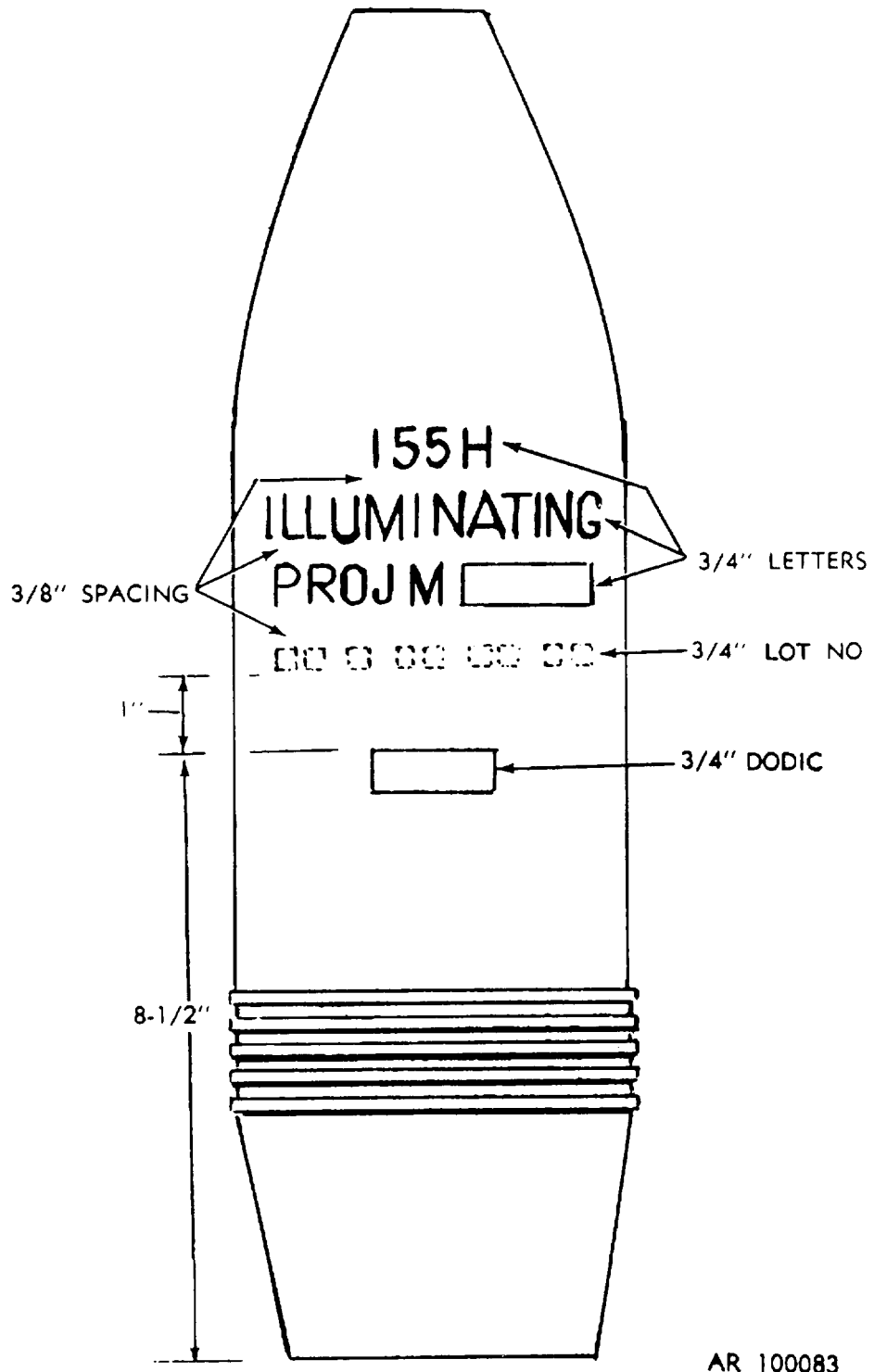
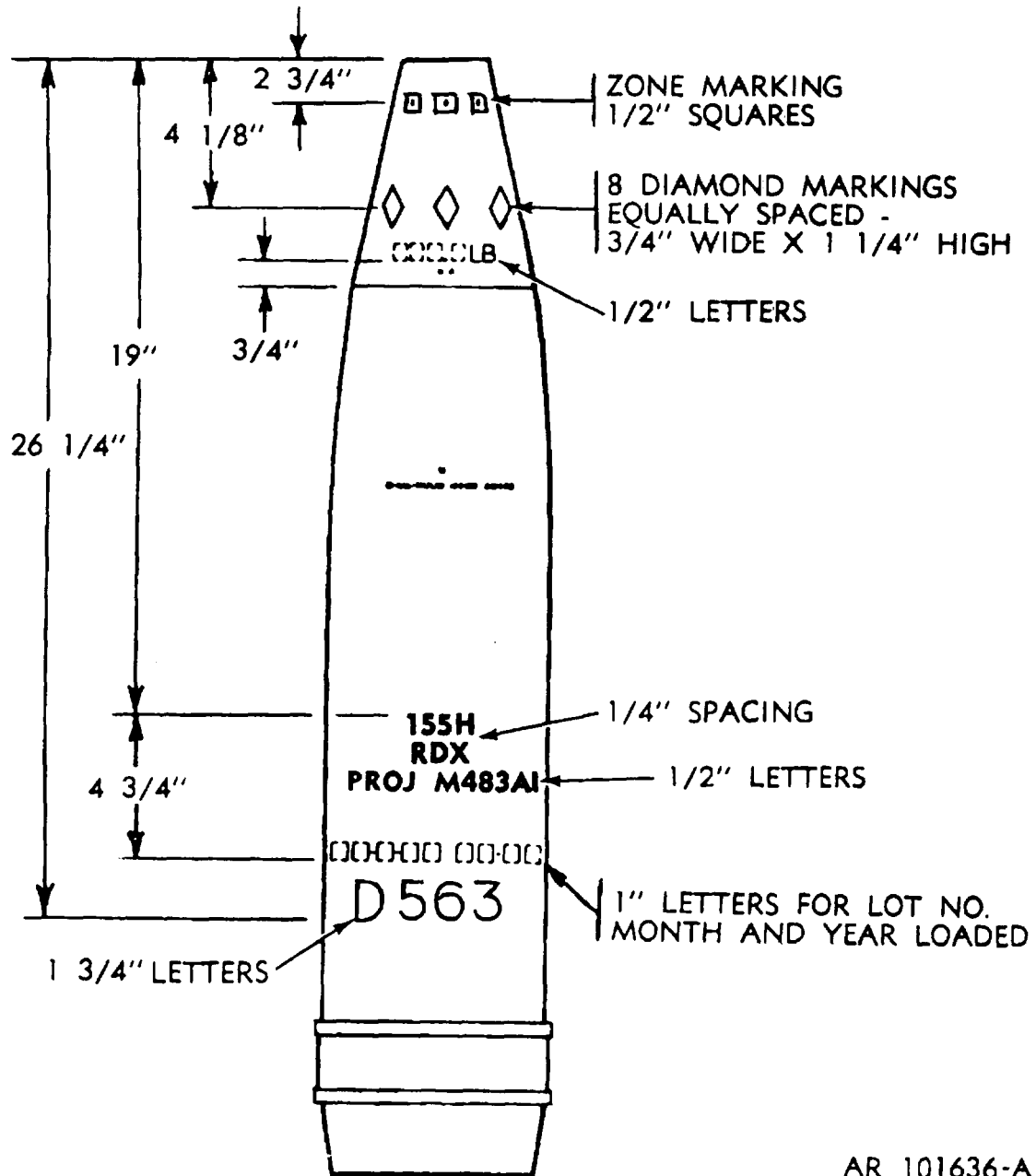
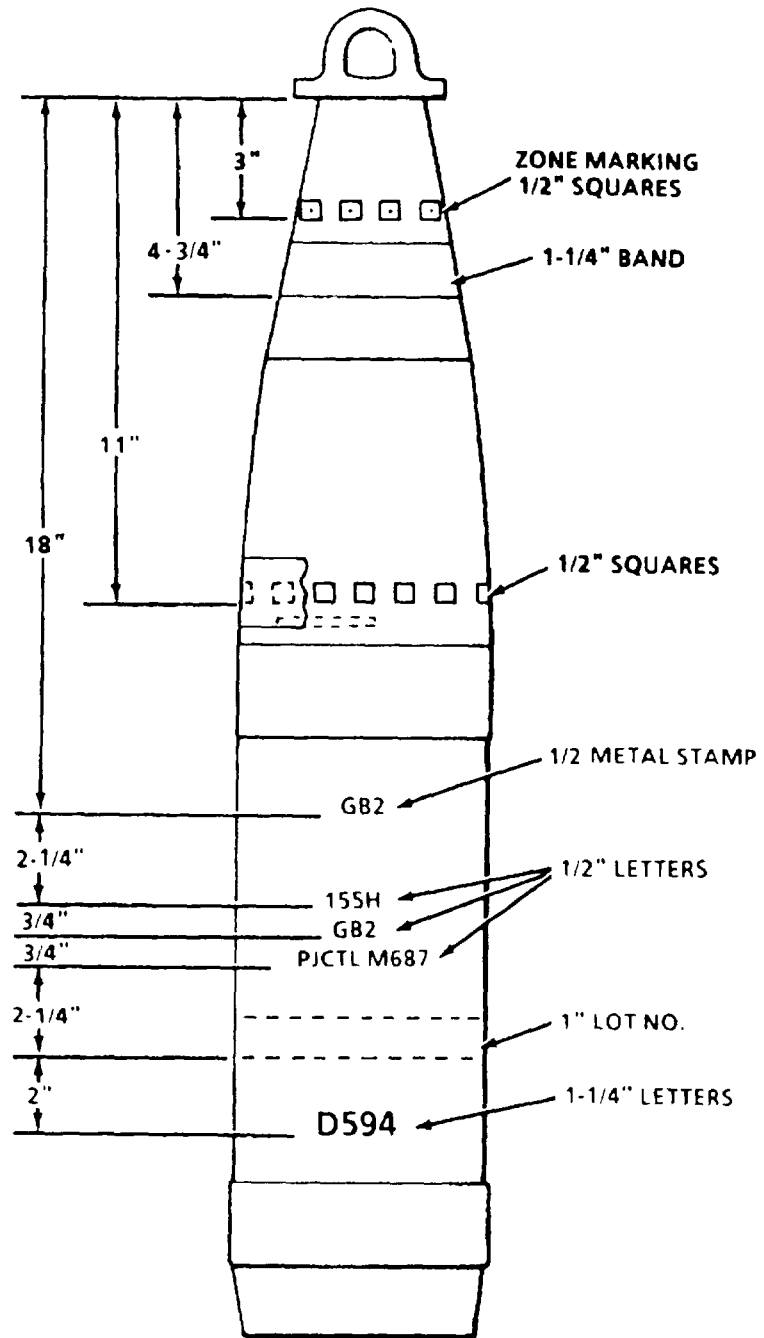

Figure E-86. Typical marking for 155mm howitzer projectile M118 series and M485 series.



AR 101636-A

Figure E-87. Typical marking for 155mm howitzer projectile M483A1.



ARD-2773

Figure E-88. Typical marking for 155mm howitzer projectile, M687.

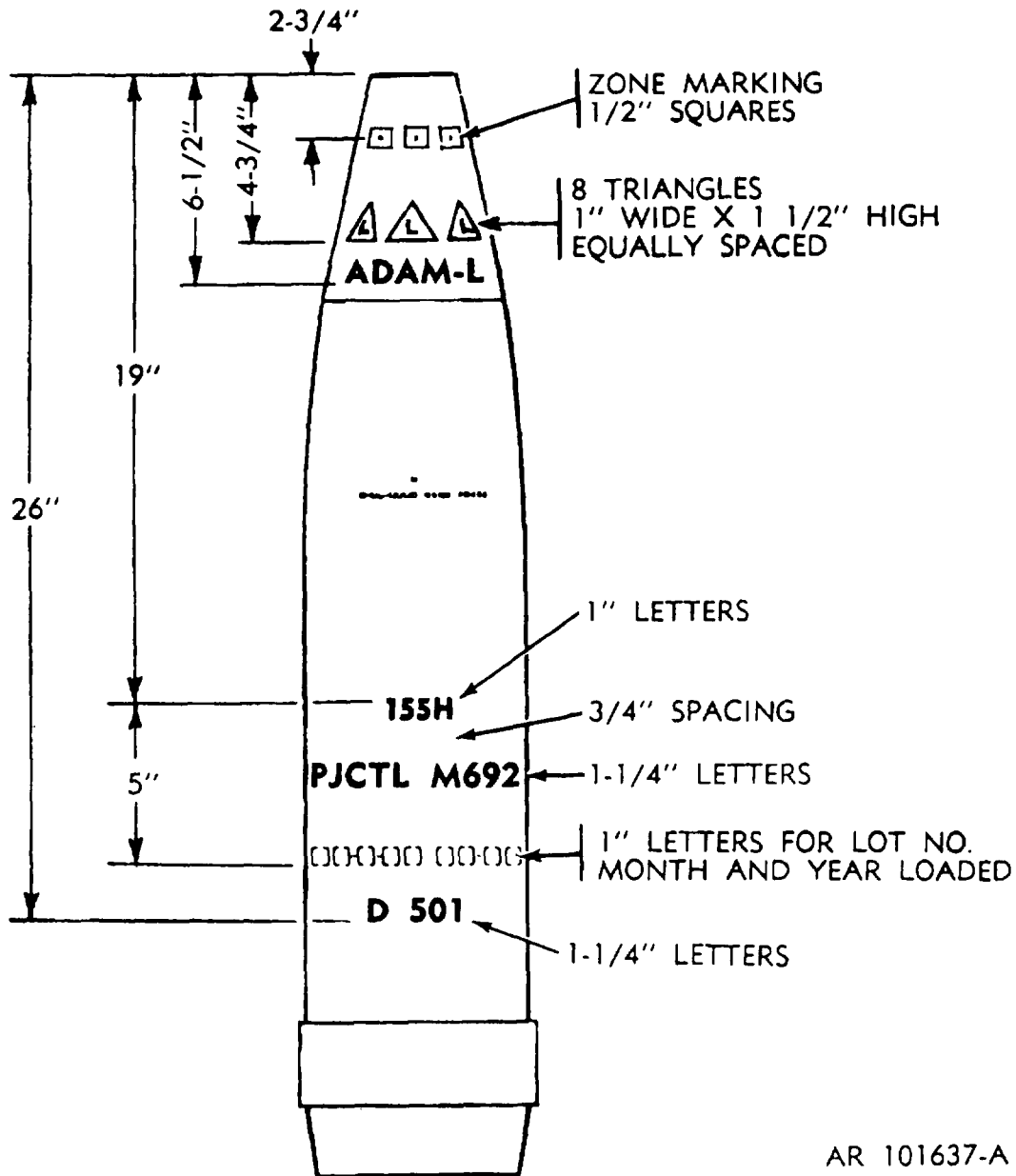

AR 101637-A

Figure E-89. Typical marking for 155mm howitzer projectile M692.

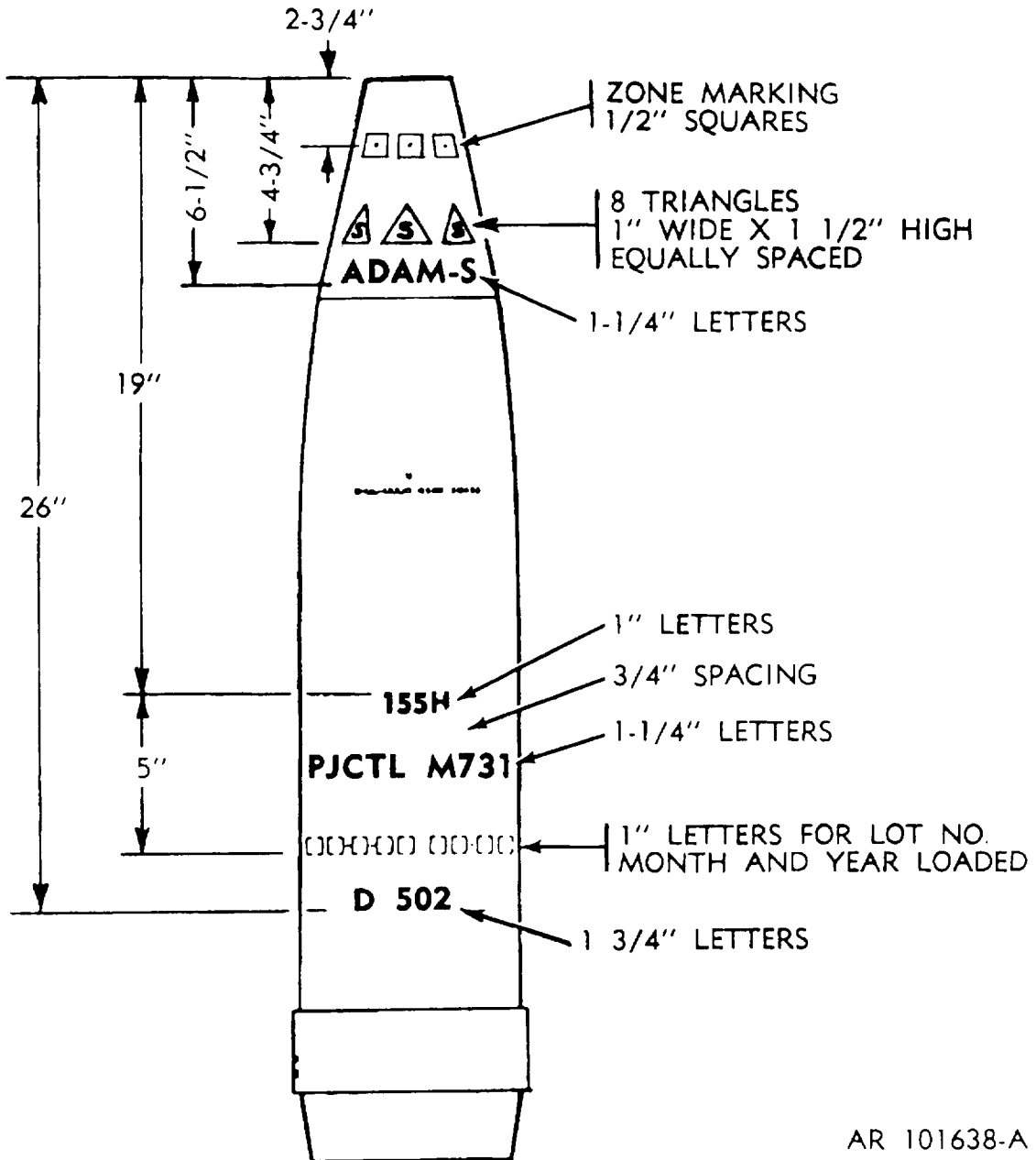

AR 101638-A

Figure E-90. Typical marking for 155mm howitzer projectile M731.

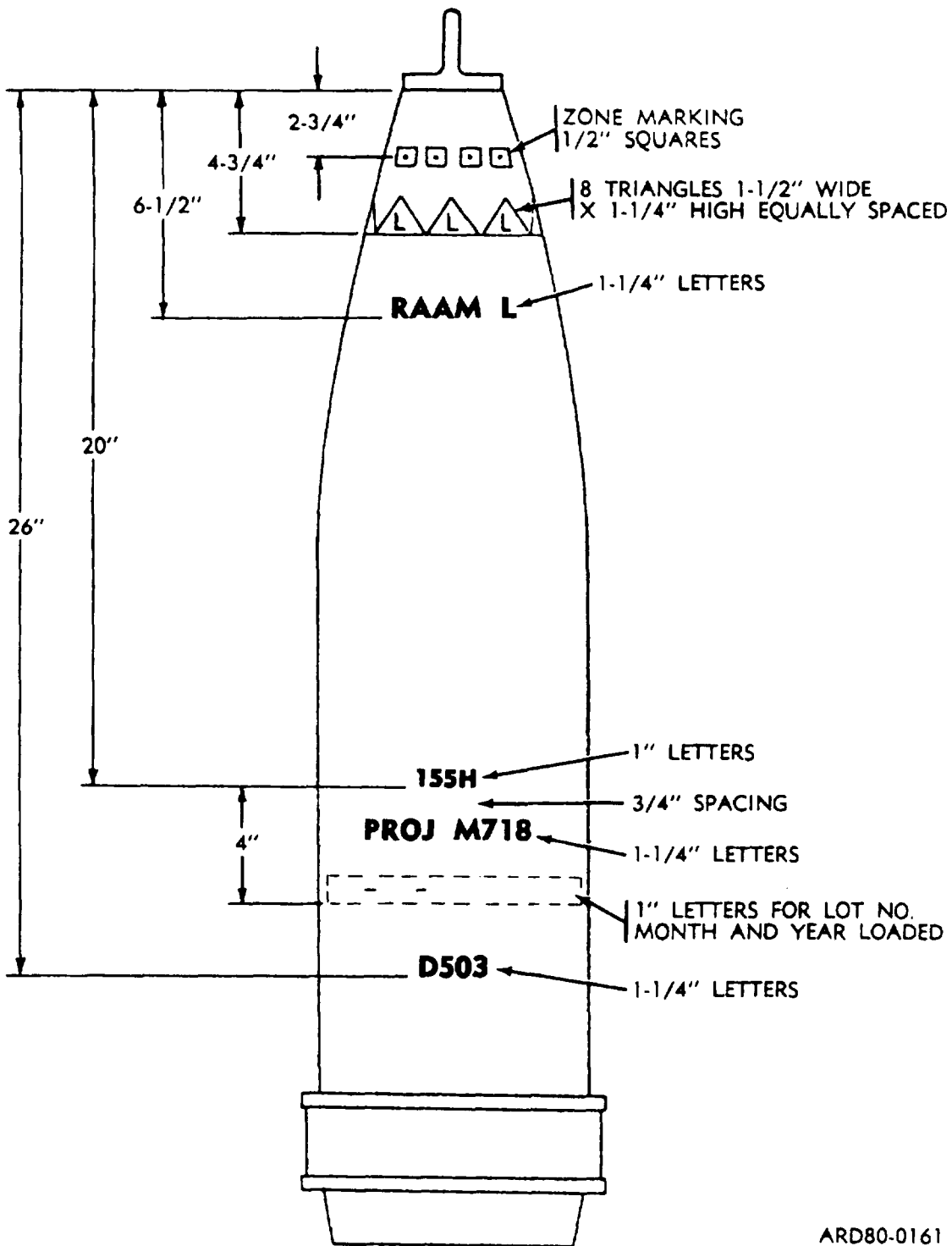

ARD80-0161

Figure E-91. Typical marking for 155mm howitzer projectile M718.

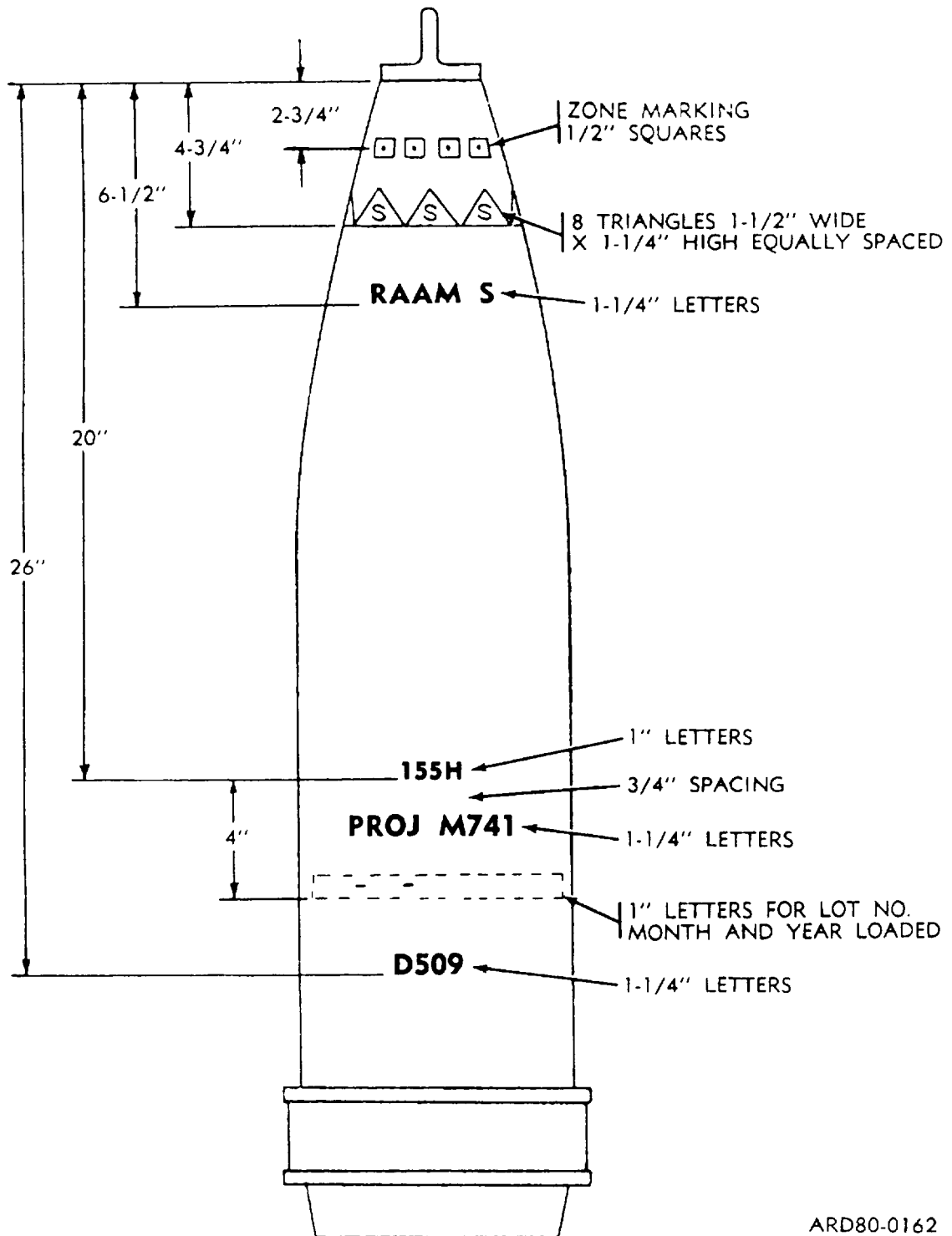

ARD80-0162

Figure E-92. Typical marking for 155mm howitzer projectile M741.

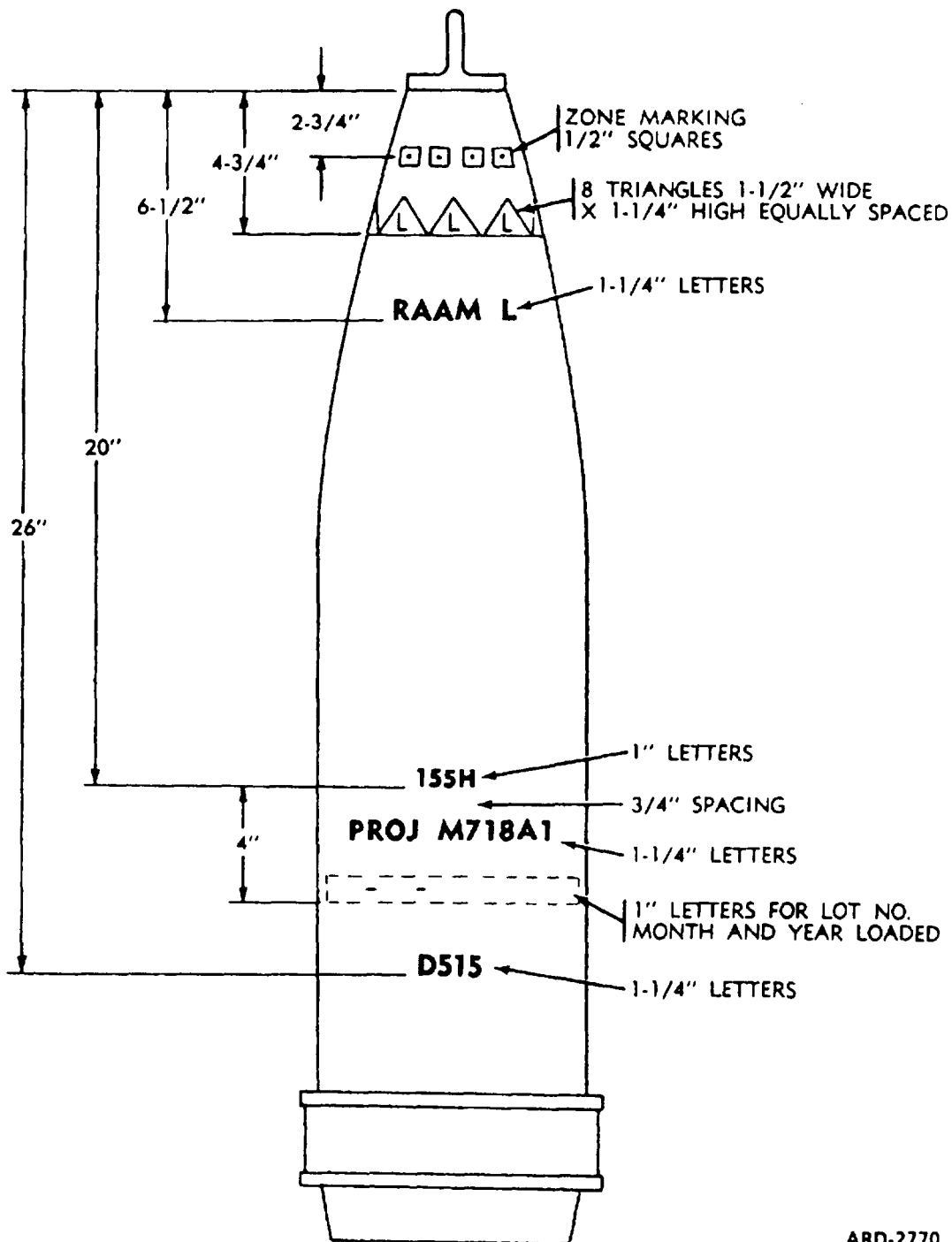

ARD-2770

Figure E-93. Typical marking for 155mm howitzer projectile, M718A1.

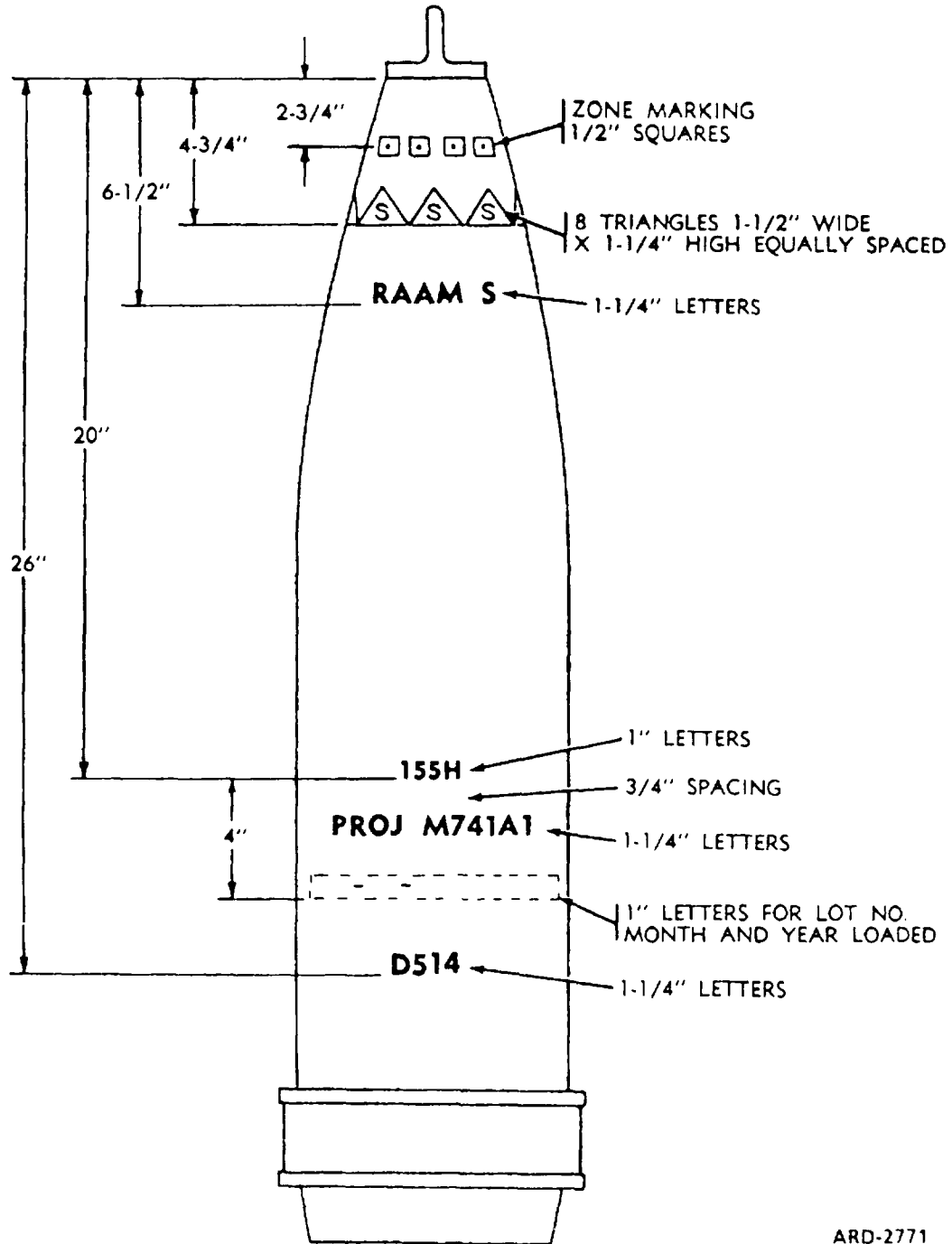

ARD-2771

Figure E-94. Typical marking for 155mm howitzer projectile, M741A1.

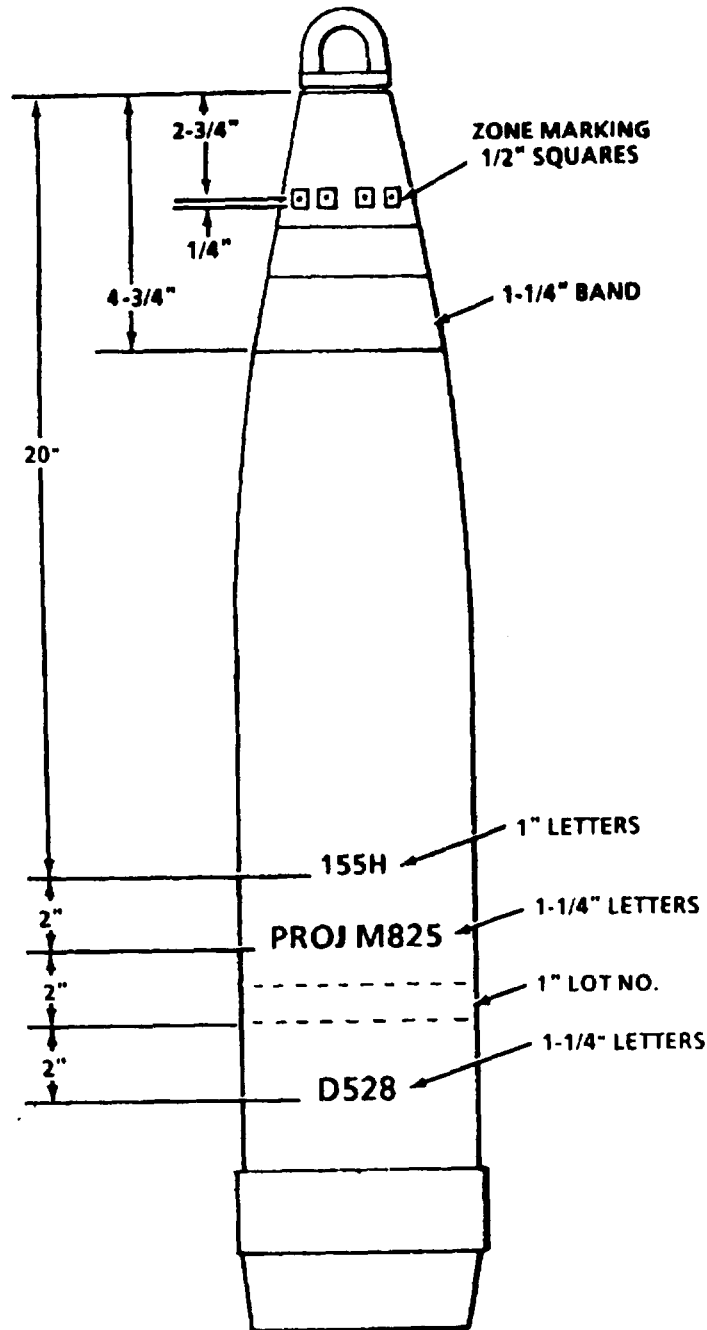

ARD-2774

Figure E-95. Typical marking for 155mm howitzer projectile, M825.

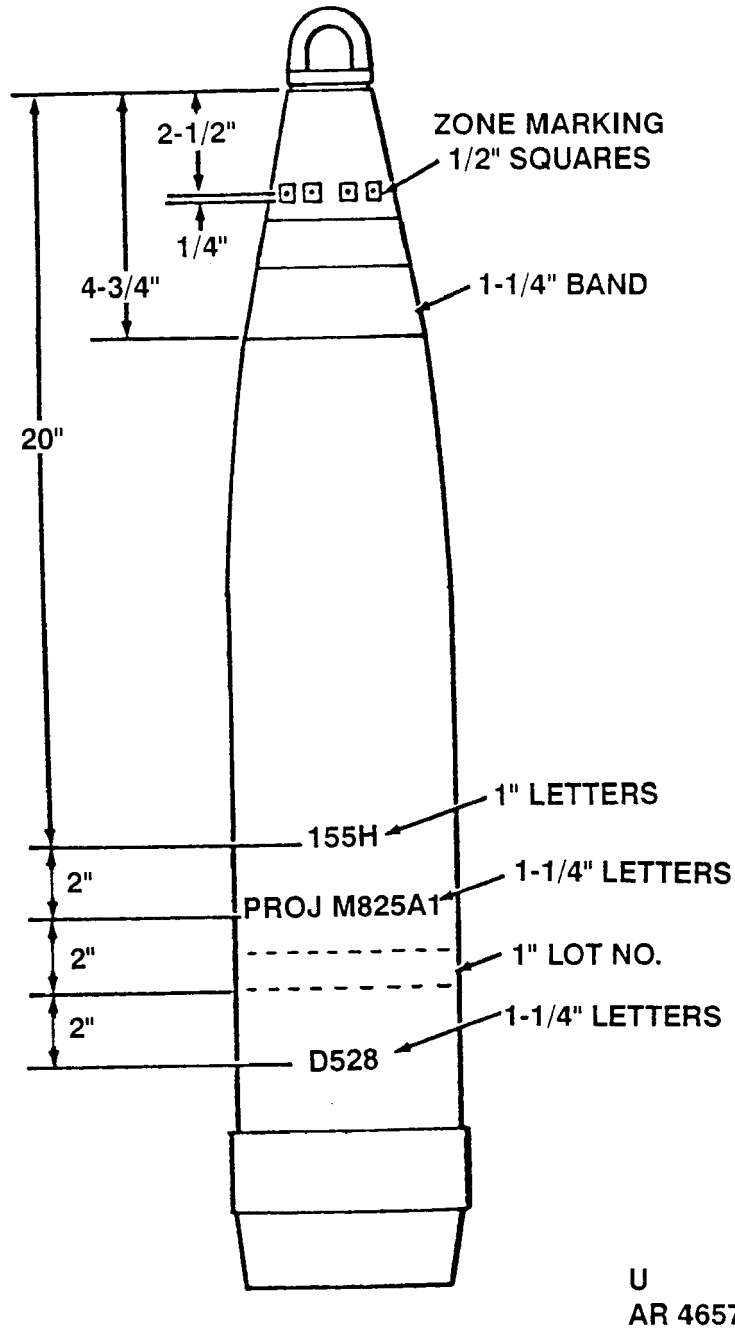
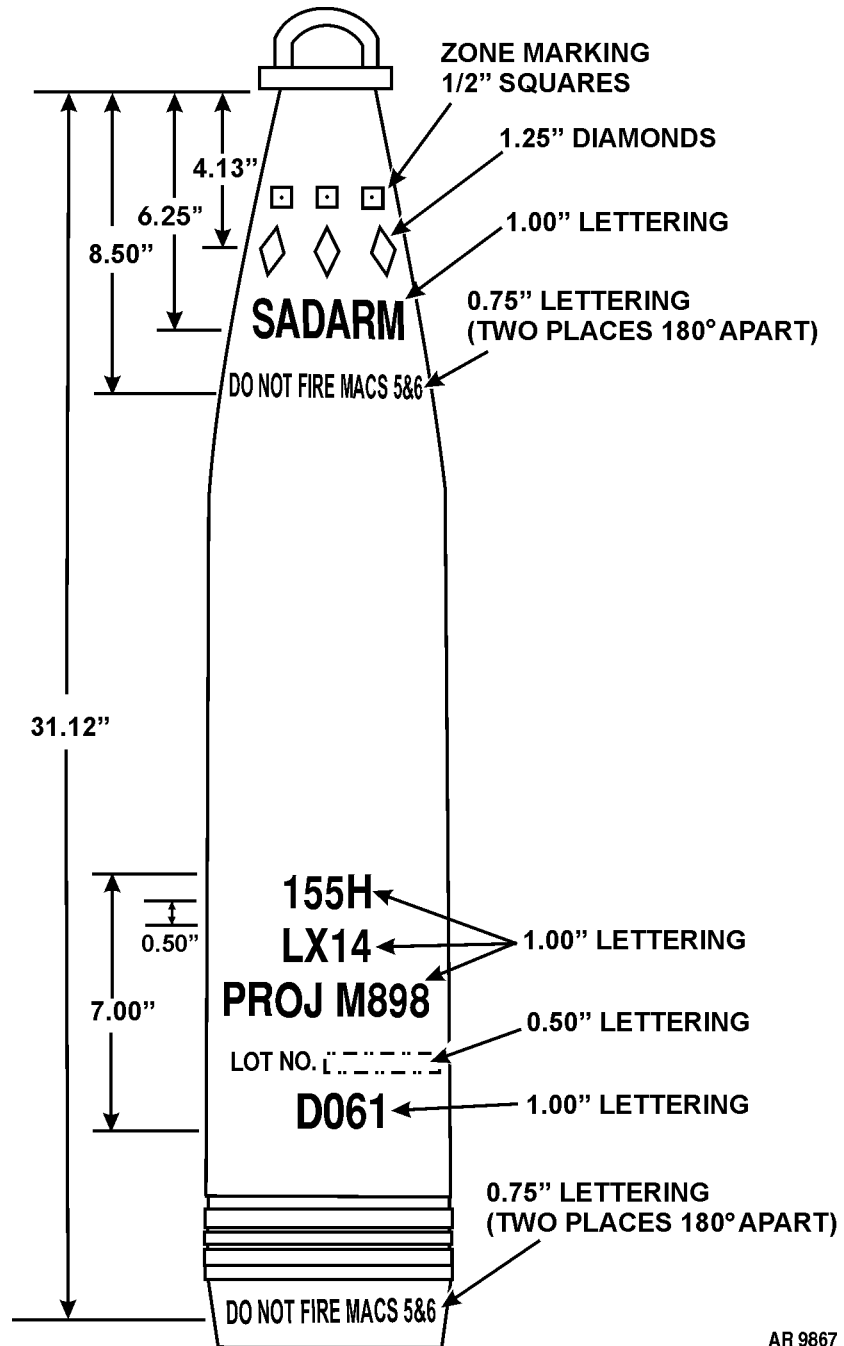

Figure E-96. Typical marking for 155mm howitzer projectile, M825A1.



AR 9867

Figure E-96.1. Typical marking for 155mm howitzer projectile, M898 (SADARM).

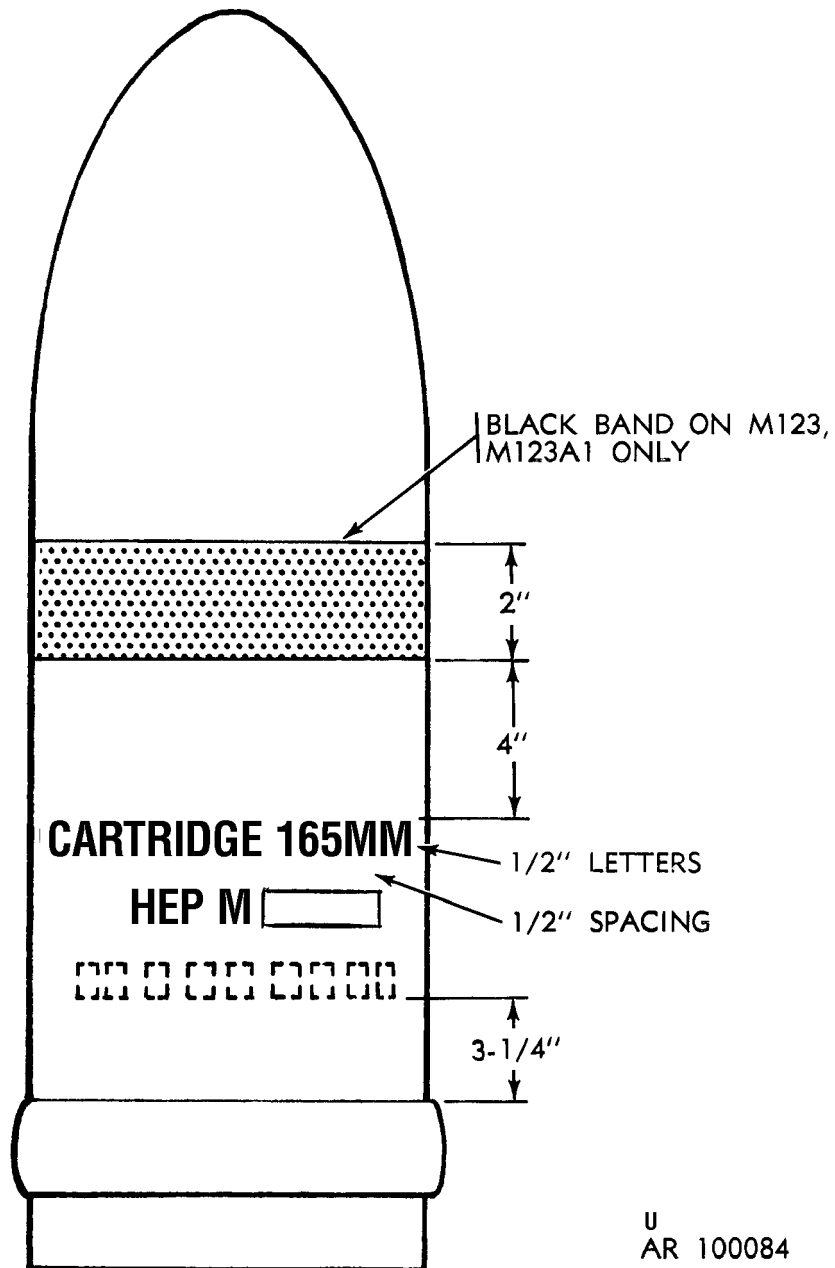

Figure E-97. Typical marking for 165mm gun projectiles M123 series and M623.

THIS PAGE INTENTIONALLY LEFT BLANK

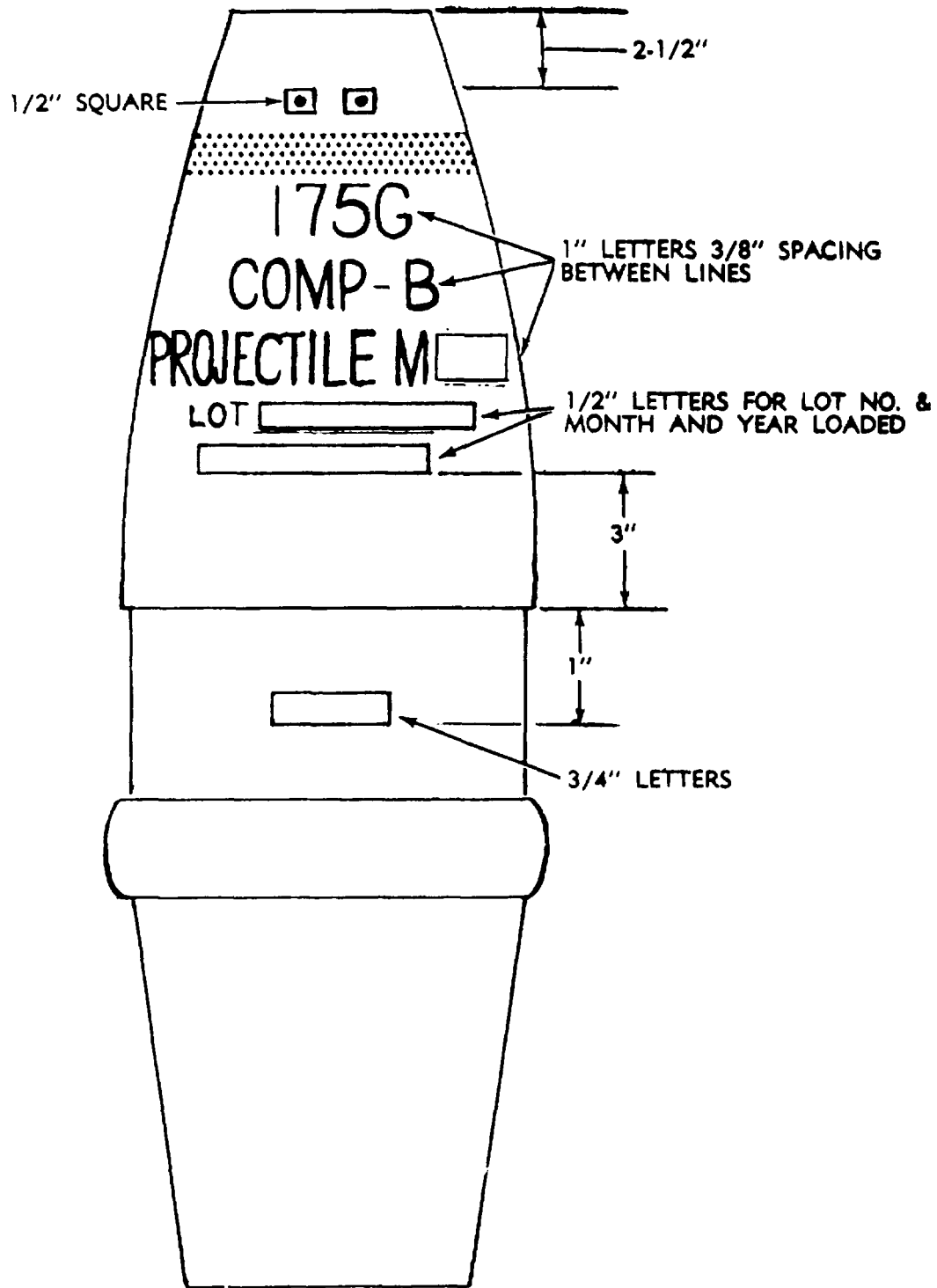

Figure E-98. Typical marking for 175mm gun projectile.

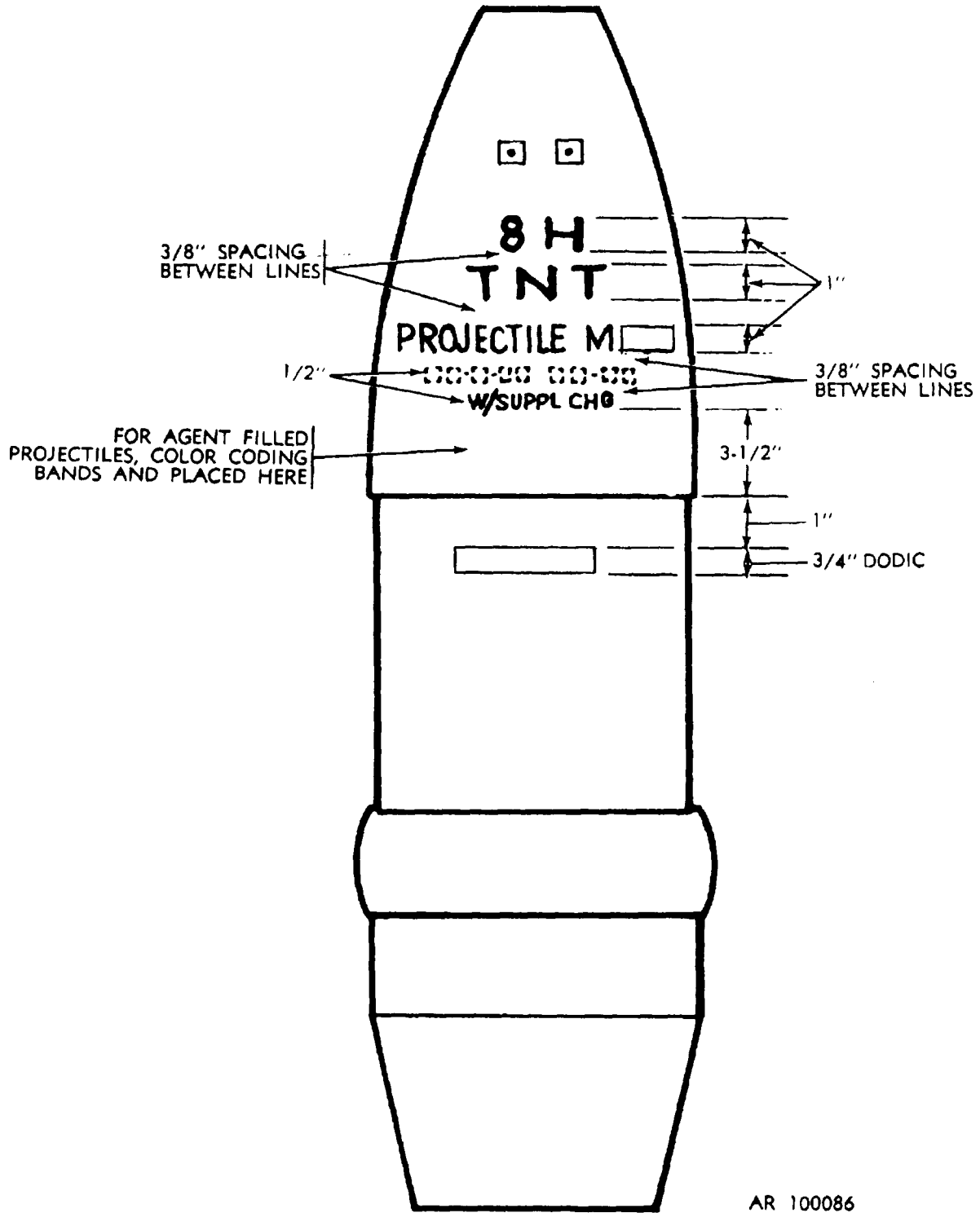

Figure E-99. Typical marking for 8-in. howitzer projectile M106.

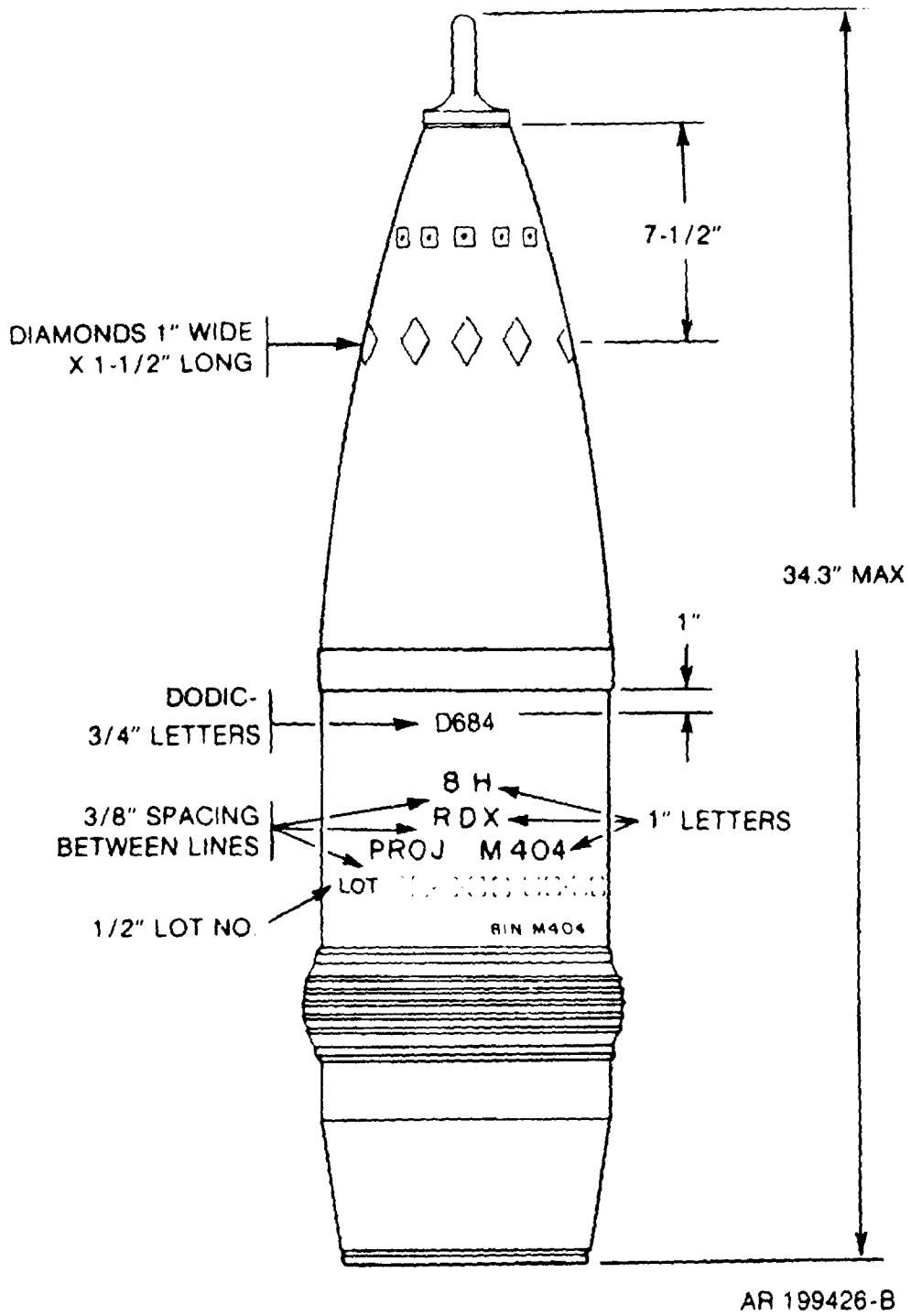
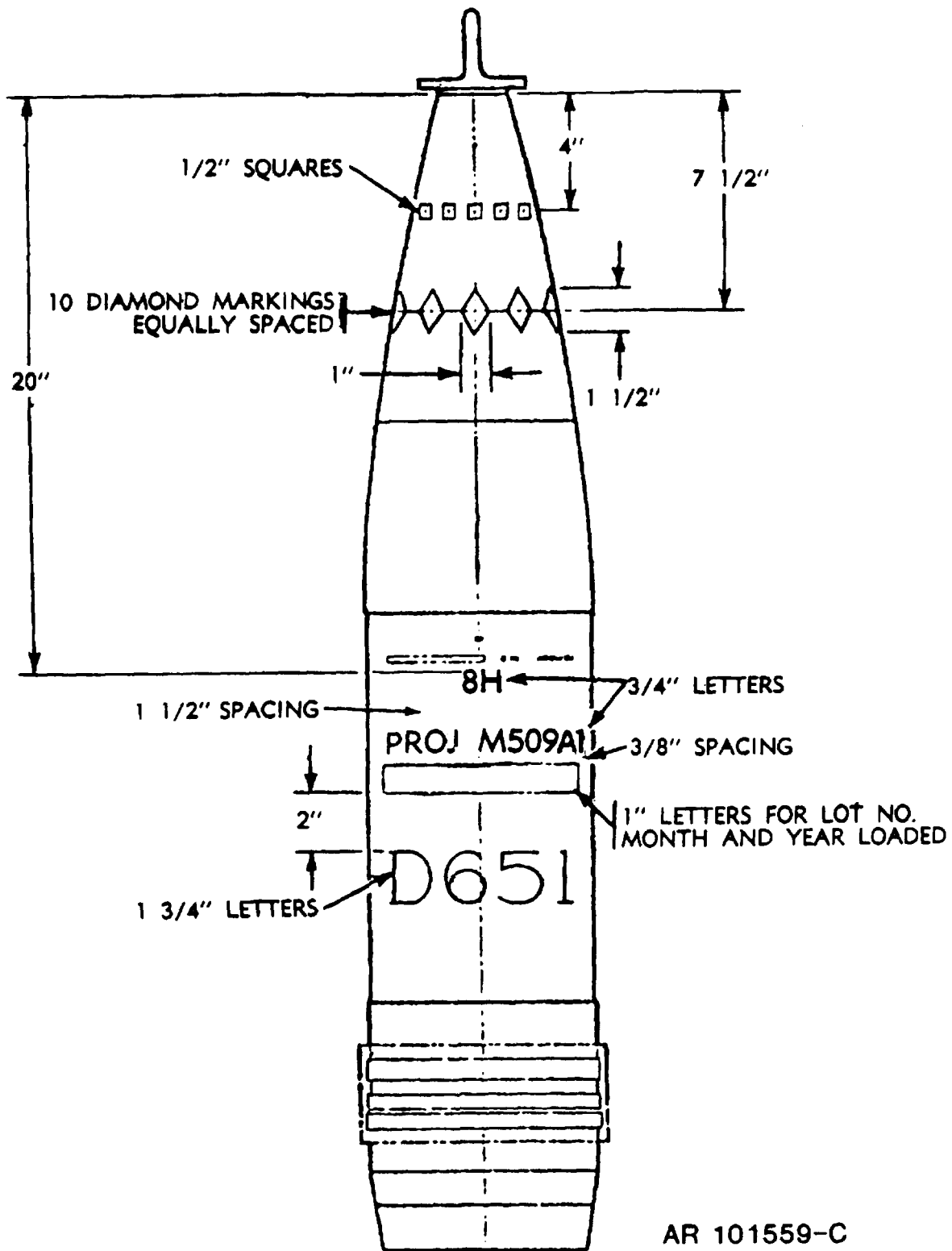

Figure E-100. Typical marking for 8-inch howitzer projectile M404.



AR 101559-C

Figure E-101. Typical marking for 8-inch howitzer projectile M509A1.

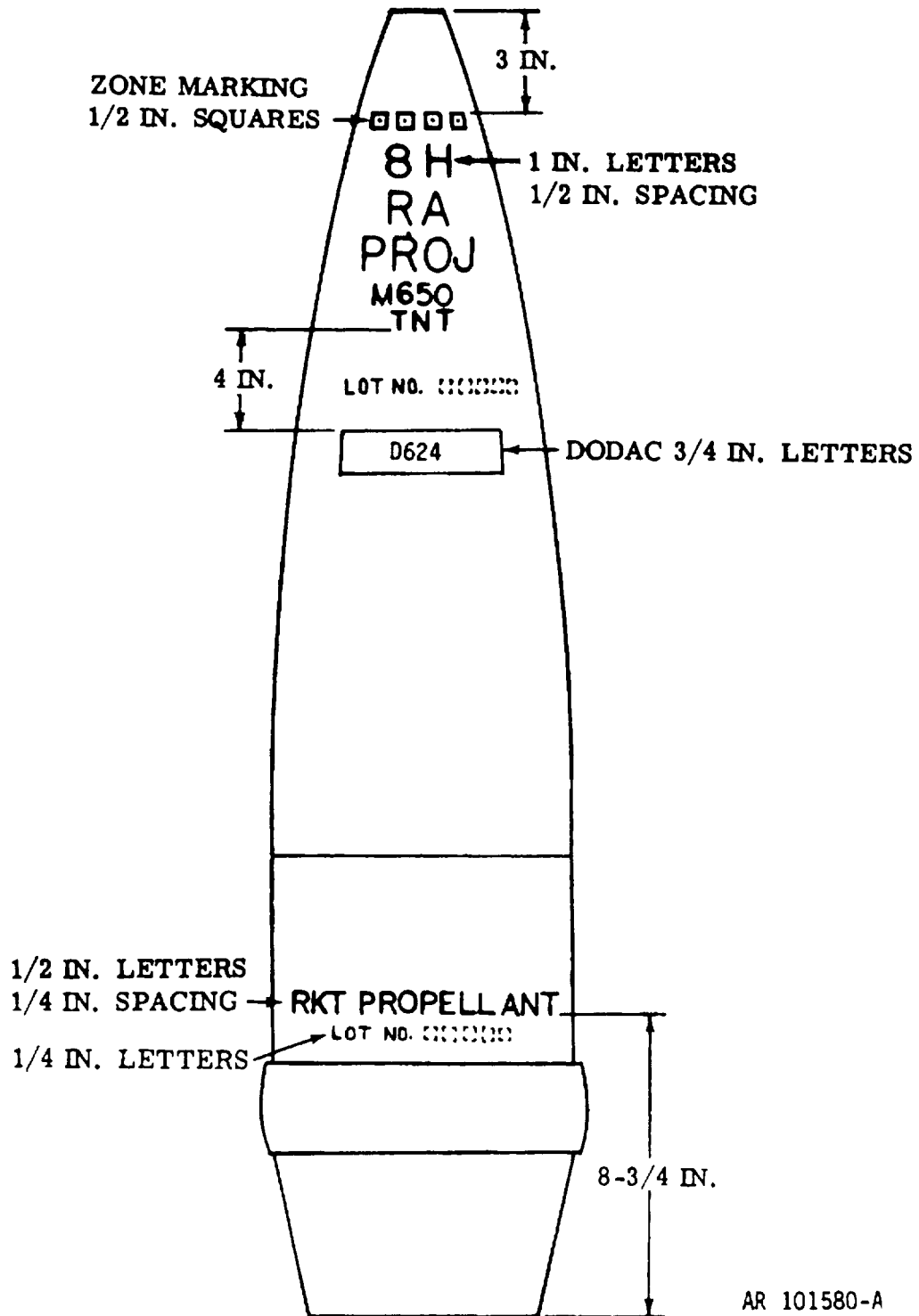
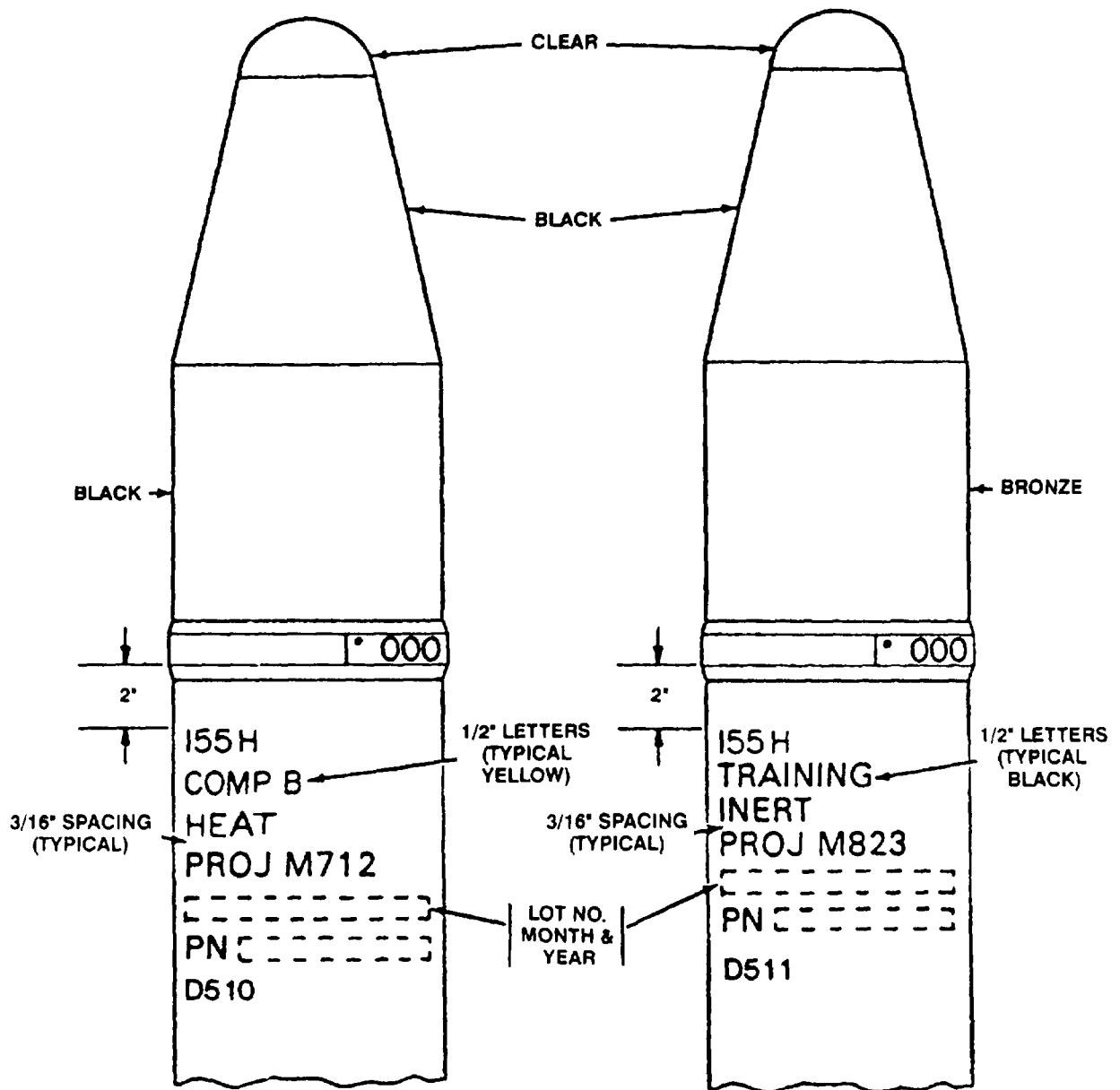
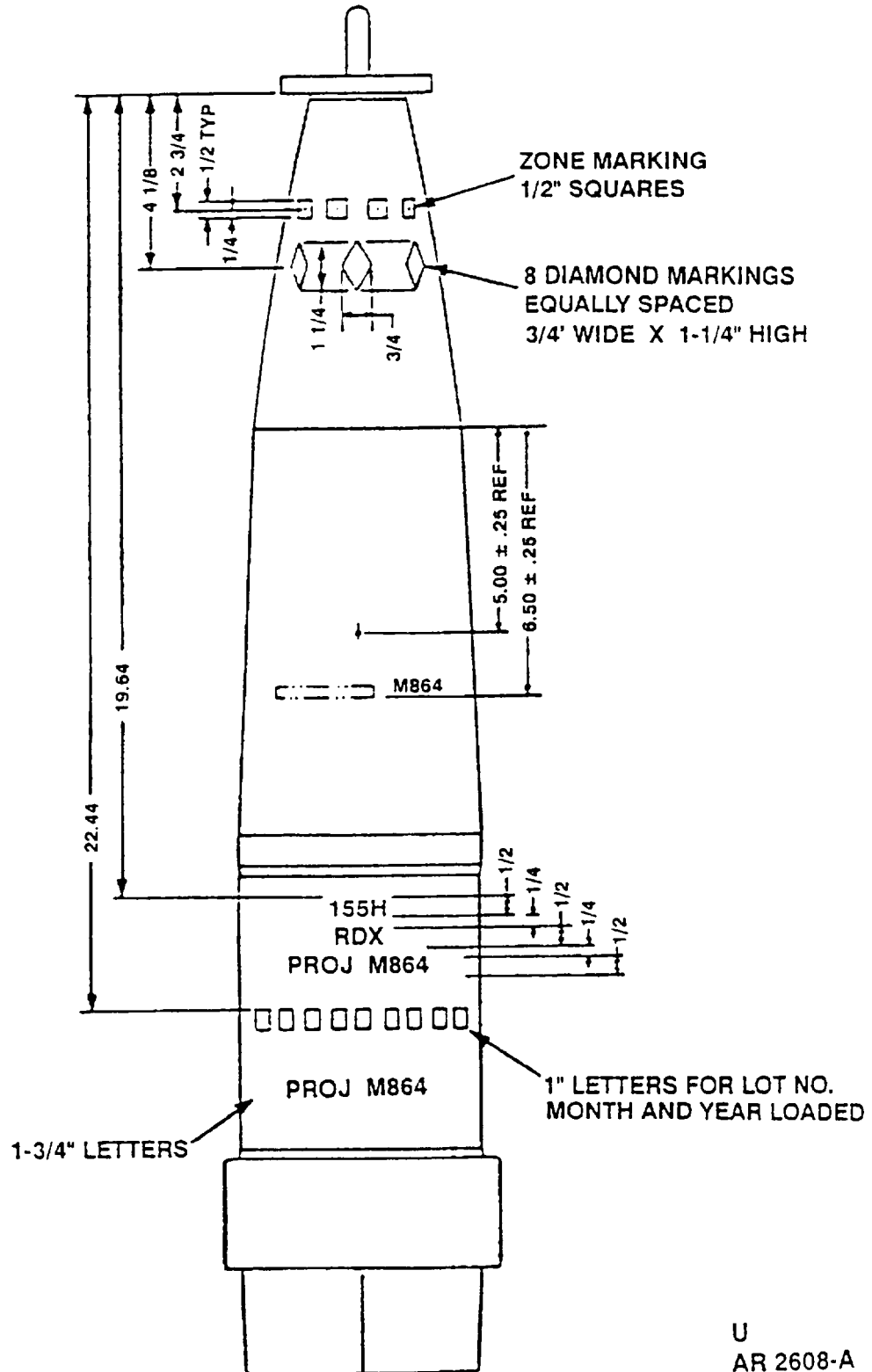

Figure E-102. Typical marking for 8-inch, projectile M650.



U
AR 198464-A

Figure E-103. Typical marking for 155mm projectiles M712 and M823 (Copperhead).



U
AR 2608-A

Figure E-104. Typical marking for 155mm howitzer projectile, M864.

THIS PAGE INTENTIONALLY LEFT BLANK

APPENDIX F

SPECIAL HANDLING EQUIPMENT FOR AMMUNITION

F-1. Introduction

a. A new series of slings and beams specifically designed to handle palletized heavy projectiles has been added (1987) to the IDS, IGS Ammunition Tool Set (NSN 4940-00-322-6058). These items, which have been added to SC 4940-95-Ail, are detailed in Table F-1 and illustrated in Figures E-1 through E-3.

b. Twice the number of slings to equip the beams authorized are provided to allow the operating unit to be rigging one set of pallets while another set is being lifted.

c. The slings and beams covered in this Appendix are designed specifically for lifting of palletized projectiles. A sufficient quantity has been authorized (1987) to equip all lifting equipment available in the standard AMMUNITION COMPANY TOE.

F-2. Operation

a. Operation of the Slings and Beams is to be in accordance with standard Army Materials Handling practice. Observe Cautions and Warnings at all times when using this equipment - it is designed to handle VERY HEAVY LOADS. Heavy loads must be treated with respect.

CAUTION

THE SIX LEGGED SLING IS DESIGNED TO LIFT NO MORE THAN TWO PALLETS OF 8-INCH OR THREE PALLETS OF 155MM PROJECTILES. NEVER EXCEED THESE LIMITS AND ALWAYS HOOK THE SLING TO TWO PROJECTILE NOSE RINGS IN EACH PALLET.

b. The maximum rated lifting capacities are given in Table F-1 both in pounds and number of pallets. These limits must not be exceeded for reasons of potential damage to the equipment and safety of operating personnel.

CAUTION

RIG THE SLING TO PALLETS ONLY IN THE MANNER SHOWN IN FIGURES F-4 AND F-5.

c. Rig sling to pallet of projectile before connecting the sling to the lifting hook. Rig the sling in accordance with figures F-4 (155mm projectiles) or F-5 (8-inch projectiles). Always assure that sling cables are not kinked such that they will loop when lifted.

d. Assure that quick release pin is securely in position before using the double beam. Suspend beam across bed of transport vehicle when hooking a load.

e. When hooking beam to crane, assure that chains are not twisted to assure that they will not loop when the beam is lifted.

WARNING

ALWAYS USE A GUIDE LINE TO MANEUVER THE BEAMS. NEVER MANEUVER THE BEAMS BY HAND. SEVERE PERSONNEL INJURY OR DEATH COULD RESULT.

CAUTION

ALWAYS ASSURE THAN AN EQUAL NUMBER OF THE SAME SIZE PALLETS ARE SECURED TO THE OPPOSITE ENDS OF THE BEAMS. AN UNBALANCED LOAD CAN CAUSE A GREAT DEAL OF DAMAGE WHEN LIFTED.

f. Slings must be attached to the beams in a balanced manner. Always assure that each one of a pair of lifting hooks is positioned equally distant from the center of the beam, and that each of the pair has an identical load. This will assure a level, controllable lift of the

load. A guide line must be attached to one end of the beam to facilitate maneuvering of the load. The center hook on the beams is to be used only when an odd number of pallets is to be lifted. Be especially careful not to exceed the maximum loads allowed when using the center hook.

g. Maintenance of this equipment is primarily the responsibility of the using unit. No formal PMCS is required, however, each piece should be visually inspected and checked to

assure it is securely assembled and undamaged. Do not use a sling leg with a broken or severely rusted cable strand. Obtain a replacement sling as soon as possible.

h. Nut and bolt type component replacement is authorized on both the single and double beams to the extent allowed by the parts given in Table F-2. Table F-2 is given in lieu of a RPSTL which will be issued when the beams are Type Classified Standard as separately issued items.

Table F-1. Slings and Beams for Ammunition Handling

NSN	Item	Quantity Authorized (For Total Set)
3940-01-241-7400	Sling, Multiple Leg	112
3940-01-247-3681	Beam, Single	8
3940-01-247-3682	Beam, Double	10

NOTE: There are maximum quantities. The actual number kept on hand will be at the discretion of the company commander.

**Table F-2. Slings and Beams for Ammunition Handling
(Lifting Capacity)**

Maximum Lifting Capacity Hook (lb)	Maximum Lifting Capacity Total (lb)	Maximum Number Slings	Maximum Number 155mm	Maximum Number Pallets 8-inch
900	5400	N/A	3	2
2750	5500	2	6	4
2750	11,000	4	12	8

Table F-2. Replacement Parts for Ammunition Handling Slings

NSN	Item	Quantity Beam	Quantity Double Beam
3940-01-248-6454	Link, Hoisting	1	1
4010-01-113-2106	Link, Chain Detachable	6	12
4010-00-824-1404	Chain, Welded	2	4
5305-00-942-2196	Screw, Cap, Hexagon H	4	8
5305-00-044-4153	Screw, Cap, Hexagon H	4	8
5310-00-637-9541	Washer, Lock	4	8
5310-00-584-5272	Washer, Lock	4	8
4010-01-242-8777	Link, Chain, End	2	4
5305-01-240-4024	Screw, Cap, Hexagon H	1	1
5310-01-077-9743	Nut, Plain, Slotted, H	1	1
5315-00-298-1481	Pin, Cotter	1	1
4030-01-241-7269	Hook, Hoist	3	5
5305-01-245-0706	Screw, Cap, Hexagon		1
5310-00-823-8803	Washer, Flat		1
5340-01-247-5481	Pin, Quick Release		1
3940-01-247-7400	Sling, Multiple Leg		1

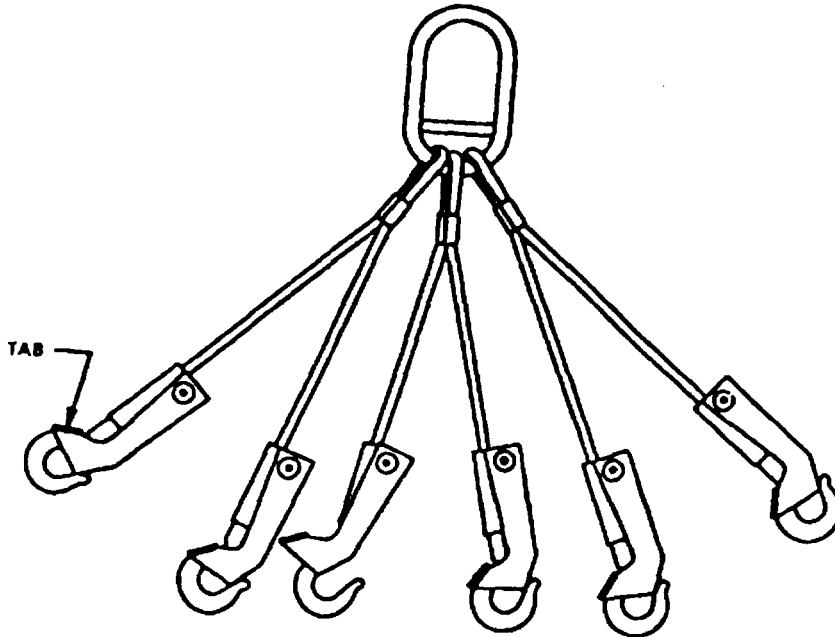

ARD 2900

Figure F-1. Six legged sling, palletized projectile.

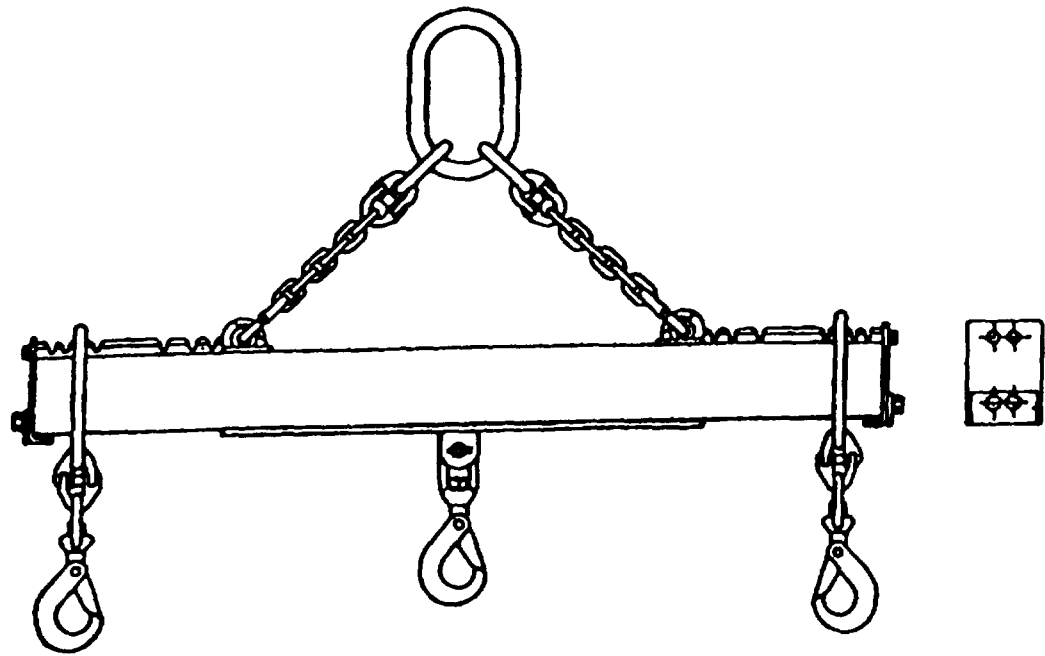

ARD 2801

Figure F-2. Single beam, palletized projectile.

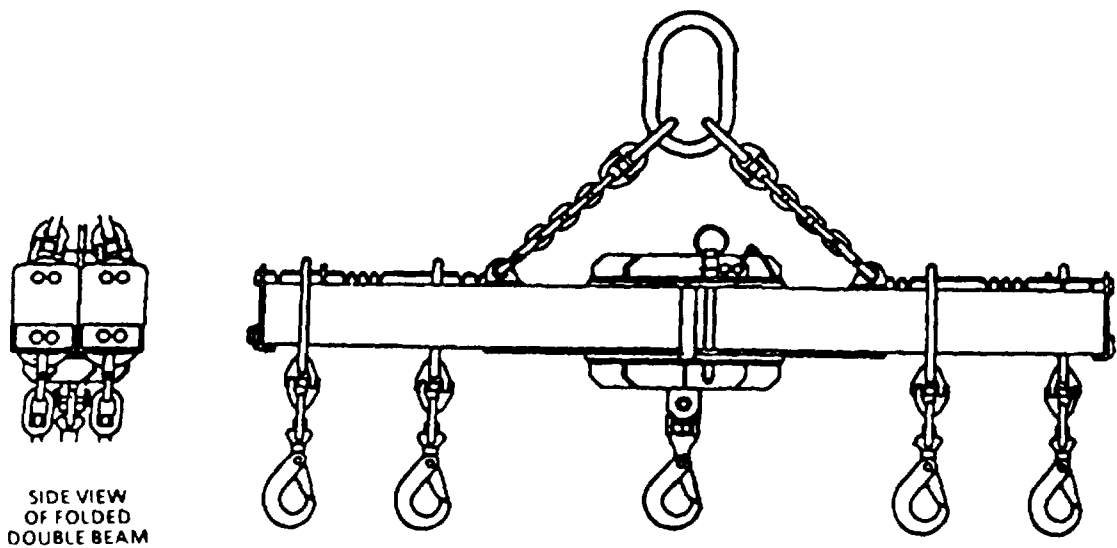

SIDE VIEW
OF FOLDED
DOUBLE BEAM

ARD 2802

Figure F-3. Double beam, palletized projectile.

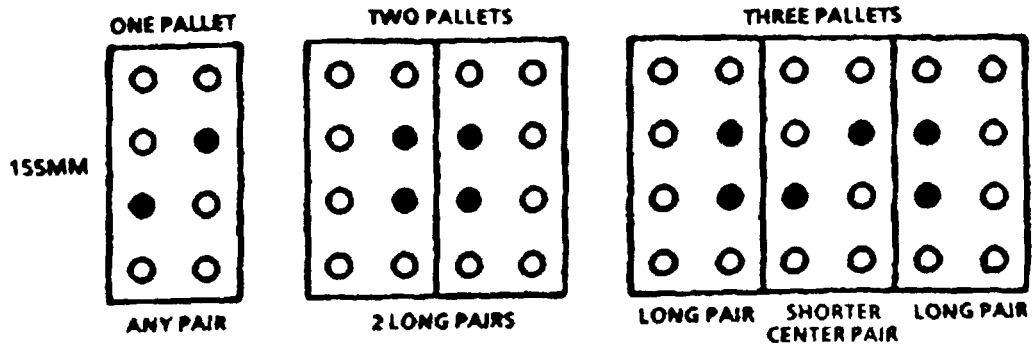

ARD 2803

NOTE: Projectiles to be hooked are indicated by darkened circles.

Figure F-4. Rigging of 155mm palletized projectiles.

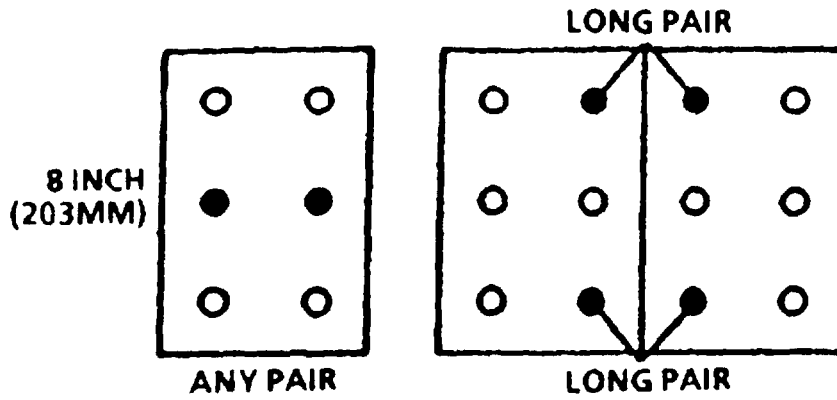

ARD 2804

NOTE: Projectiles to be hooked are indicated by darkened circles.

Figure F-5. Rigging of 8-inch palletized projectiles.

By Order of the Secretary of the Army:

Official:

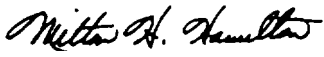
MILTON H. HAMILTON
*Administrative Assistant to the
Secretary of the Army*
07861

GORDON R. SULLIVAN
*General, United States Army
Chief of Staff*

Distribution:

To be distributed in accordance with DA Form 12-40-E, Block 0709, for TM 9-1300-251-34&P.

FILL IN YOUR
UNIT'S ADDRESS

FOLD BACK

DEPARTMENT OF THE ARMY

OFFICIAL BUSINESS

Commander
U.S. Army TACOM, Armament Research,
Development and Engineering Center
ATTN: AMSTA-AR-LSB
Picatinny Arsenal, New Jersey 07806-5000

FOLD BACK

CUT ALONG DOTTED LINE

